

⚠ Read this handbook thoroughly and understand the whole information contained before trying to operate, inspect and service your machine!

**OPERATING &
MAINTENANCE
INSTRUCTIONS**

**VIBRATING
ROLLER**

**MODEL
CR271**

From CR271 – 5CR3-30101

PREFACE

This operator's manual serves as a guide for the use of your SAKAI CR271 Vibrating Rollers for those who are new to the machine, and also for the people who have experience in using the machine and want to refresh their knowledge for the machine.

Read this manual thoroughly and try to fully understand the information before operating your machine. Keep this handbook at hand whenever you do your work.

When an instruction manual is lost or is damaged and is not legible, replace it immediately.

The main subjects of this manual are:

(1) Basic precautions for safety, (2) Operation, (3) Daily maintenance and (4) Specifications. For operation and maintenance of the engine, refer to the Engine Instruction Manual furnished separately. Descriptions in this manual can differ from the machine instructions of your machine due to the results of the investigation and improvement in its design. If you have any inquiry regarding your machine or this manual, contact our distributors.

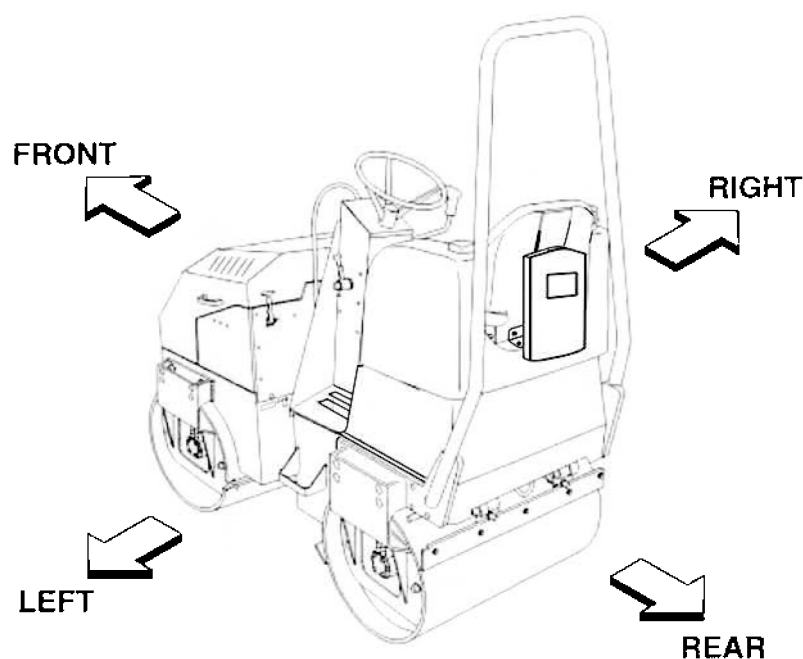

WARNING

The engine exhaust from this product contains chemicals known to the State of California to cause cancer, birth defects or other reproductive harm.

California Proposition 65

This product contains or emits chemicals known to the state of California to cause cancer, birth defects or other reproductive harm.

CONTENTS

PREFACE

MACHINE AND ENGINE IDENTIFICATION NUMBERS 1

SAFETY NOTICES 2

1 BASIC PRECAUTIONS FOR SAFETY 4

1.1 General Precautions..... 4

1.2 Preparation for Safe Operation 8

1.3 Before Starting the Engine 9

1.4 After Starting the Engine 10

1.5 During Operation..... 11

1.6 Loading and Unloading 14

1.7 Transportation 14

1.8 Handling the Battery 15

1.9 Towing..... 16

1.10 Before Servicing 17

1.11 During Servicing 19

1.12 Safety Decals 22

2 OPERATION

2.1 Instruments and Controls 24

2.1.1 Operator's station 24

2.1.2 Gauges and warning lamps 25

2.1.3 Switches 26

2.1.4 Operating levers and knob..... 28

2.1.5 Fuse..... 30

2.2 Handling and Adjustments 30

2.2.1 Scraper adjustment and replacement..... 30

2.3 Operation..... 31

2.3.1 Before-starting inspection 31

2.3.2 Starting the engine..... 32

2.3.3 After starting the engine..... 33

2.3.4 Traveling 34

2.3.5 Stopping / Parking 35

2.3.6 Stopping the engine..... 35

2.3.7 Check after stopping the engine 36

2.4 Vibratory Operation 37

2.5 Sprinkler 38

2.6	Precautions for Work.....	39
2.6.1	Compaction operation.....	39
2.6.2	When going downhill.....	39
2.6.3	On a slope	39
2.7	Applicable Jobs	39
2.8	After Operation	40
2.9	Loading and Unloading	41
2.9.1	Use of a truck or trailer equipped with a winch	41
2.9.2	Self-propelling.....	42
2.9.3	Use of a mobile crane.....	43
2.10	After Loading the Machine	43
2.11	Transportation	44
2.12	Operation in Cold Weather.....	44
2.12.1	Fuel oil and grease	44
2.12.2	Battery	44
2.13	When the Cold Season is Over	45
2.14	For a Long Storage Period	45
2.15	During the Storage Period.....	45
2.16	When the Battery Has Discharged.....	46
2.16.1	Connection and disconnection of booster cables	46
3	PERIODICAL MAINTENANCE.....	48
3.1	Precautions	48
3.2	Walk-around Checking.....	49
3.3	Periodical Maintenance Points	50
3.4	Maintenance Procedure	52
(1)	Every 10 hours or daily.....	52
(2)	First 20 hours.....	53
(3)	First 50 hours.....	53
(4)	Every 50 hours	54
(5)	Every 100 hours	55
(6)	Every 200 hours	56
(7)	Every 230 hours	56
(8)	Every 500 hours	57
(9)	As required	59
3.5	Consumable Parts.....	61
3.6	Feeding Water and Lubricants	62
3.7	Electric Wiring Diagram.....	64
4	SPECIFICATIONS.....	66

MACHINE AND ENGINE IDENTIFICATION NUMBERS

When ordering parts or making inquiries about your machine, the following information is requested.

(1) Machine model

Indicated on the dashboard in the operator's station.

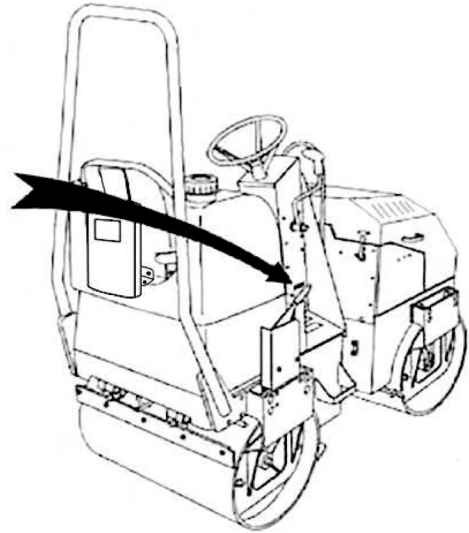
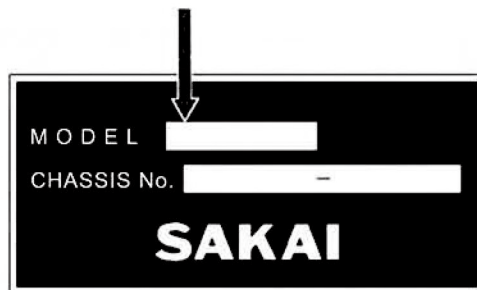

(2) Machine serial number

CR271 → 4CR2 - ○○○○○○

Location

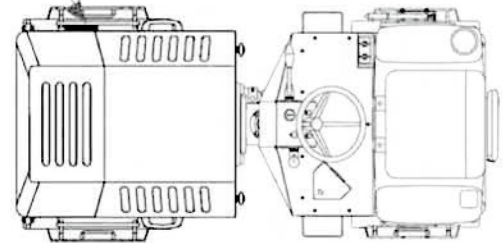

(3) Engine serial number

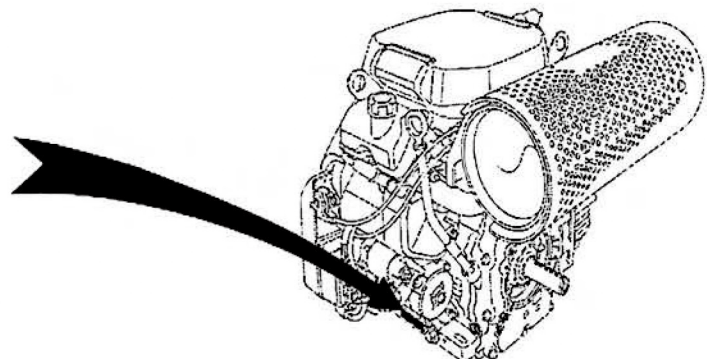
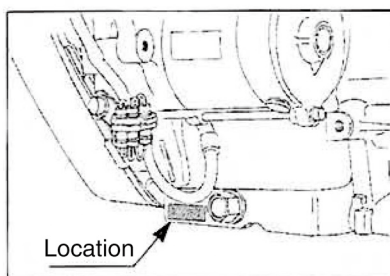







SAFETY NOTICES

For the safe use of your machine, correct handling and periodical maintenance are of utmost importance. Thoroughly read the safety precautions described in this manual. Do not attempt to operate and maintain your machine until you gain a full understanding of these safety statements.

This manual covers the proper and safe method of driving and handling of this machine for its intended use. When this machine is used in a manner other than those covered in this manual, you must assume responsibility for your own personal safety.

In this manual and on the machine, you will find safety notices. Each safety notice starts with a signal word as shown below:

- | | |
|--|--|
|  DANGER | Denotes that there is an extreme hazard. If you fail to take proper precautions, it is highly likely that you could be killed or seriously injured (The color of the symbol  is red). |
|  WARNING | Denotes that there is a hazard. If you fail to take proper precautions, you could be killed or seriously injured (Symbol  is orange). |
|  CAUTION | Calls attention to safety practices. If you fail to take proper precautions, you could be injured or cause damage to the machine (Symbol  is yellow). |

It is almost impossible for the safety notices in this manual and on the machine to cover all the potential dangers. Keep alert to possible dangers not mentioned in this manual and on the decals.

 **WARNING**

Do not operate your machine before you read its operator's manual thoroughly.

Incorrect operation can kill or cause injury.

It is your responsibility to operate the machine safely.

☆ Making alterations to the machine.

Please do not make alterations to the machine without permission for safety reasons.

We shall not be held responsible for injuries, death or breakdowns caused by alterations.

☆ Basic precautions for safe operation of your machine are described beginning on page 4.

☆ To operate and work with your machine, you must be qualified.

1 BASIC PRECAUTIONS FOR SAFETY

1 BASIC PRECAUTIONS FOR SAFETY

1.1 General Precautions

■ Ensure proper management of health

- People under the influence of alcohol, drugs, lack of sleep or health problems must avoid driving or repairing the machine at all times, as it may lead to serious accidents.

■ Turn off cell phones

- Turn off cell phones while driving or repairing the machine. Never drive while talking on a cell phone, as it may lead to serious accidents.

■ Read the operator's manual thoroughly

- Understand the functions of the controls and gauges. Familiarize yourself with their location and how to operate them. Understand the meaning of all the symbols.



■ When an instruction manual is lost or is damaged and is not legible, replace it immediately

■ Understanding the uses for the machine

- This machine was developed and manufactured mainly for the purpose of rolling compaction in engineering works. Do not use it for any other purpose. Vibration rolling compaction under conditions of excessive compaction, or using it to crush rocks can damage the machine.

■ Obey the worksite rules

- Follow noise standards and worksite rules such as matters forbidden or to be attended to, and working procedures.

⚠ WARNING: Negligence of these instructions can lead to accidents.

1 BASIC PRECAUTIONS FOR SAFETY

■ Wear protective clothing appropriate to work

- Wear clothing, safety shoes and hard hat to suit your work.
- Do not wear clothing and accessories that tend to get caught in the controls or protruded portions of the machine. Do not wear oily clothing.
- Depending on the type of job, wear gloves, earplugs safety goggles or a mask.



■ Know the work area in advance

- Know the terrain, geology and conditions of the road surface at the worksite. Start working after securing safety such as stationing a guardsman or putting up barriers where there is a risk of falling of the machine or collapse of shoulder.

■ The operator must make prior checks when moving the machine to a hazardous area under unusual conditions

■ Provide against an accident

- Decide in advance the means of communication in an emergency. Know the location and use of an extinguisher and first-aid kit.

■ Realize the capability of the machine

- Thoroughly understand the performance of your machine and correctly operate the machine to meet the requirements of the job site. Operating the machine beyond its capabilities may lead to an accident. Use your machine within its capability.

■ The machines not equipped with ROPS must not be operated on the slope or unsafe ground

■ The machines not equipped with CABIN must not be operated in the bad weather or a harmful contaminated zone

1 BASIC PRECAUTIONS FOR SAFETY

■ Do not use a machine which has not been serviced correctly at regular intervals

- Before working, perform necessary inspections. Start operation only after making certain the machine is in good operating condition. If found to be abnormal, report to the responsible person and have the fault corrected. Operate the machine after making sure that it is safe to operate.

■ Do not allow anyone to enter the work area except for authorized personnel

- Always conduct the work paying attention to the workers around the machine.



■ Beware when operating moving parts

- When operating moving parts such as covers, be sure to understand the way they move and take care not to get the hands and feet caught.

■ Operator must sit in the seat when operating the machine

■ Be careful of hot parts

- After your machine has operated for some time, the coolant, engine oil and hydraulic fluid will become hot and the pressure will build up. If, in this state, you try to remove the filler caps, drain the oil or replace the filters, you can get burned. Perform this work in accordance with the correct procedures with the machine cooled down.
- To remove the radiator cap, slowly loosen the cap to relieve the pressure with the engine stopped and the coolant cooled down (For the radiator cap with a lever, lift the lever to release the trapped pressure).
- When removing the filler cap on the hydraulic tank, release the trapped pressure by turning it out slowly to prevent the oil from gushing out (For the cap with a lever, lift the lever to release the trapped pressure).
- While the engine is running or immediately after it has been stopped, do not touch the engine, muffler, exhaust pipes, oil hydraulic pumps, oil hydraulic motors, lights, etc., as they will be hot.
- Resin and metallic parts may become hot under direct sunlight on a hot day. Direct contact with such parts may cause burns, so be sure to wear clothing and protective equipment appropriate for the job.



⚠ WARNING: Negligence of these instructions can lead to accidents.

1 BASIC PRECAUTIONS FOR SAFETY

■ Be careful with fire

- The fuel, oil, and antifreeze will catch fire if open flames or ignition sources are used close to them. Particularly, the fuel is highly flammable.



- Do not smoke or use a match or cigarette lighter close to inflammables (combustibles).
- When refueling, stop the engine and do not smoke.
- The filler caps of the fuel and oil tanks must be kept tight.



■ Ensuring safety in a fire

- Machine fires may cause serious injuries or death, so stop the engine by turning the starter switch to the OFF position, then move away from the machine as quickly as possible.

■ While the engine is running or immediately after it has been turned off, do not touch the muffler, exhaust pipe or DPF

- While the engine is running or immediately after it has been turned off, do not touch the muffler, exhaust pipe or DPF, as they will be hot.

■ Mount on or dismount from your machine after it has come to a complete stop

- For getting on and off, face the machine and use the handrail and step.
- Watch your step when getting on or off the machine.
- Do not jump on or off a machine, particularly when it is moving.
- When getting on and off an articulated machine, straighten it out before stopping the machine. In the turned state, there is danger that personnel gets caught because the getting on and off space narrows.

■ Be careful not to fall

- Falling off the machine may cause serious injuries or death, so do not place your feet anywhere other than on the steps, and in the driver's seat.

■ Do not lock out yourself when leaving the machines

- Always bring the key with you by pulling it out from the starting switch when leaving the machine.

1 BASIC PRECAUTIONS FOR SAFETY

■ To handle the hydraulic fluid

- Wear safety goggles to protect your eyes from contact with hydraulic fluid. It can irritate your eyes.
If the fluid contacts your eyes, flush with clean water for 15 minutes and get medical aid.
- The fluid can also irritate your skin. When handling it, wear rubber gloves to avoid contact with it. In case of skin contact, wash with soap and water.
- Be careful not to swallow the fluid. It can cause diarrhea and emesis.
If swallowed, do not try to vomit. Get medical help immediately.



■ Do not use worn tires (Tire installed)

- Tires may be damaged when they are scratched on curb stones, when the machine runs over irregular surfaces of roads or projections on roads, and when the machine is operated suddenly.
- Continued use of damaged tires will cause them to blow out. Replace them with new ones.

1.2 Preparation for Safe Operation

■ Clean the step, operator's station and floor board and brake pedal

- Do not place parts, tools or unnecessary articles on the step, operator's station and floor board.
- Keep the step, floor board, brake pedal, controls and handholds free from muds, oil, ice or water, as they can cause slippage. Repair them if found to be damaged. Tighten loose bolts.
- Keep your boot soles free of oil or muds. They can slip, leading to an accident.

■ Inspect your machine before operation

- Check your machine for damage such as cracks and deformation. If found to be abnormal, operate the machine after taking a proper measure to secure safety.
- Check the level of fluids (fuel, engine oil, coolant, antifreeze and hydraulic oil). Add as necessary.
- Check the area where the machine has parked for signs of leakage of oil, fuel and water. If any leakage is noticeable, determine the cause and make corrections immediately.

⚠ WARNING: Negligence of these instructions can lead to accidents.

1 BASIC PRECAUTIONS FOR SAFETY

■ Watch your distance

- When traveling on a road, bear in mind the stopping distance. Avoid excessive speed, and abrupt starting and stopping, and moving in a zigzag direction.

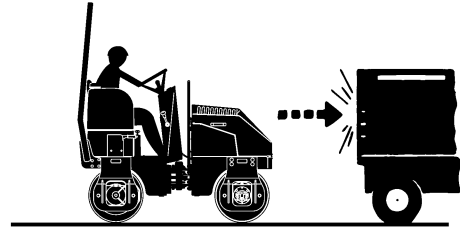

■ Understand ROPS functions (with ROPS)

- Ensure that there is no loose bolt, crack nor rust on the bodies and the attaching portions, of ROPS.
- Tighten bolts with the specified torques after ROPS are removed.
Tightening torque : **265 N·m**
- Do not weld nor drill holes to the ROPS parts without the permissions from SAKAI, because it may decrease strengths of the ROPS.
- Be sure to wear the seatbelt during operation.

1.3 Before Starting the Engine

■ It is confirmed that hood and door is closed

- Please confirm hood and door has put it away in the confirmation before it gets on.

■ Adjust the operator's seat to your most effective operating position

- Sit on the operator's seat. Adjust the seat so that your back will make contact with the seat back when the brake pedal is pressed down to the full extent. Check to be sure that the brake pedal can be fully pressed down without difficulty when you twist your body for reverse run.
- Adjust the seat to allow proper operation of the steering wheel, levers, switches, etc.

■ Secure good visibility (with CABIN)

- Keep the windowpanel clean.
- Lock the windows and doors no matter whether they are open or closed.
- Do not leave the doors half-closed.

■ Secure forward and backward visibilities

- Adjust the rear view mirrors and under mirrors for good visibility. If dirty, clean them. If damaged, replace.

1 BASIC PRECAUTIONS FOR SAFETY

■ Check that the horn, lamps and gauges work correctly

■ Before starting, make certain that each lever is in the neutral position and the parking brake is applied

■ When starting, sound the horn

- Before starting the engine. Make sure there is no one in the immediate vicinity and there are no obstructions around the machine.



■ Sit in the driver's seat and turn on the engine

- Do not start the engine anywhere other than from the driver's seat as there is the danger of operational mistakes.

■ Pay attention to ventilation

- Exhaust fumes are dangerous if breathed in. When starting the engine in an enclosed area, provide good ventilation with windows and doors opened.



■ Do not stand close to the exhaust gas pipe opening

- The exhaust gas from the engine is dangerous.
- Exhaust fumes are harmful if breathed in.

1.4 After Starting the Engine

■ Secure safety around the machine

- Ensure that the area around the machine is clear of personnel and obstructions. Moreover, honk the horn, indicate your intention to move, and wait a while before moving off.



■ Warm up the Engine

- Do not put your machine into motion immediately after the engine has started, let it idle for several minutes until it is at operating temperature.
- Check the area where the machine has parked for signs of leakage or oil, fuel and water. If any leakage is noticeable, determine the cause and make corrections immediately.

⚠ WARNING: Negligence of these instructions can lead to accidents.

1 BASIC PRECAUTIONS FOR SAFETY

■ Have a trial run

- Make a test run in a safe place to check that there are no abnormal signs. If found to be abnormal, correct the fault before traveling again.
- Listen for unusual sounds, and check for abnormal temperature rise. If abnormal, park the machine in a safe place and find the source of trouble before operating.

1.5 During Operation

■ Strictly observe the traffic regulations

- Follow all the traffic regulations when driving on a public road.

■ Sit in the driver's seat before starting operation

- Sit in the driver's seat before starting operation. Be sure to wear the seat belt when provided.

■ Seat belt (with seat belt)

- Be sure to wear the seat belt during operation.

■ No other person but the operator

- This machine is a one-man roller. Do not allow anyone to get on. Only the operator is allowed on this machine while it is running or in operation.

■ Before mounting, be sure areas around the machine are safe

- Before getting on the machine, make certain that there are no obstacles around the machine and no workers under it. If some workers are present or close to the machine, tell them that the machine is about to move, warning them to stay away from it.

■ Do not try to get on or off a moving machine

- Get on or off the machine after making sure it has come to a complete stop and the parking brake is applied.

■ Do not let anyone enter the work area

- There is the danger of being run over causing serious injuries or death.
- If the driver does not have a clear field of vision, assign a conductor ensure peripheral safety.

1 BASIC PRECAUTIONS FOR SAFETY

**■ To go uphill or downhill, run at a low speed.
Do not attempt to shift speeds while traveling
on a slope**

- Shifting speeds on a slope can cause unexpected running down the slope.
- Going down hill at speeds other than low range can cause the machine to run down violently.

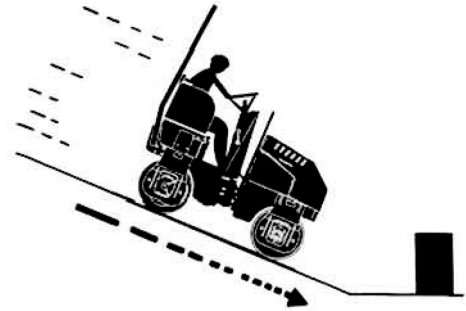

■ Refrain from inattentive driving

- Inattentive driving or driving relying on guess work can cause an accident. Use extreme care for workers present in the path of machine or around it. In case of danger, stop and sound the horn, and proceed when the area is clear of personnel or obstructions.

■ When changing the direction of travel, secure the safety on the path in the travel direction

■ Keep everyone away from the pinch points

- When making turns, do not allow anyone to come close to the pinch point.

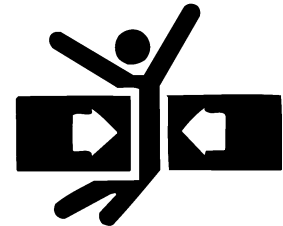

■ At night, carefully drive the machine

- Nighttime driving tends to frustrate the sense of distance. Carefully drive the machine at a speed suited to illumination. Keep the headlamps and flood lamps lighted. If necessary, provide extra lighting in the work area.

■ Avoid long hours of continual operation

- Avoid long hours of continual operation as it may lead to loss of health.

■ Repair as soon as possible if found to be defective

- If the machine is found to be faulty, stop the machine and repair. Do not operate the machine until the problem is corrected. When any warning lamp indicates faulty operation, inspect the machine after moving it to the nearest safe location.

⚠ WARNING: Negligence of these instructions can lead to accidents.

1 BASIC PRECAUTIONS FOR SAFETY

- **The machines not equipped with ROPS must not be operated on the slopes or unsafe ground**

- **The machines not equipped with CABIN must not be operated in the bad weather or a harmful contaminated zone**

- **Do not operate the machine except from the operator's seat. Do not drive in a standing posture**
 - Do not throw your legs out or lean forward. Be sure to sit in the proper position while driving the machine.

- **While making turns, do not run at abnormally high speed and do not turn the steering wheel abruptly and sharply. High speed turns, especially on soft or uneven ground, could result in a rollover**

- **For the traveling on structures such as a bridge, make certain that they can support your machine. Before traveling on the structure, you must know the load capacity of the structure and the load weight of the machine you are operating to insure safe travel across the structure**

- **Do not make turns on a slope and do not travel across sidehill. If necessary to do so, go down straight along the slope to the flat ground, move sideways and go up straight to the destination**

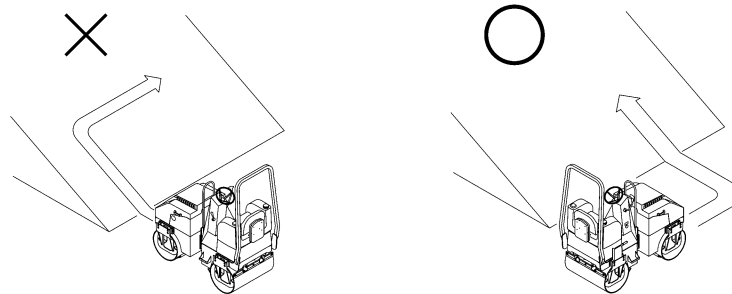

1 BASIC PRECAUTIONS FOR SAFETY

■ On a steep slope, run the machine at low speed

■ When parking

- Select level and hard ground. If necessary to park on a slope, chock the front of the drum and tire on the downside of the slope.
- When required to park on the public road, provide necessary markings such as flag, barriers and illumination. However, be sure they do not obstruct traffic.
- Stop the engine when getting off the machine. Remove the key from the starter switch, and make sure it is stored appropriately.
- Be sure not to get your hands caught in the chock when handling them.

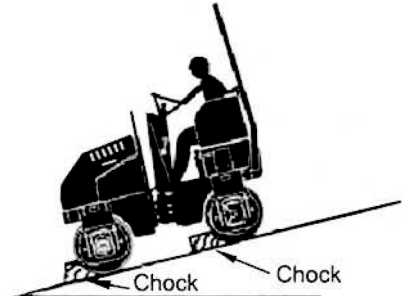

■ Beware of deformation in tires during long-term parking (if tires installed)

- The surfaces of tires in contact with the ground may become flattened, leading to their deformation (forming of flat spots) during long-term parking.
- The forming of flat spots may cause bounding or shaking during operation of the machine.
- After the forming of flat spots, driving the machine will restore the tires and remedy the situation.
- To prevent the forming of flat spots during long-term parking, inflate the tires to a higher pressure within the allowable range and drain the water from the sprinkler tank before parking. Furthermore, move the machine regularly.

1.6 Loading and Unloading

- Loading and unloading can accompany any danger. Use extreme care.
- Select level and hard ground leaving a sufficient distance from the shoulder of a road or bank.
- Use sturdy ramps with proper width, length and thickness which allow safe loading and unloading. If they deflect considerably under load, apply wooden blocks to reinforce the ramps.
- To prevent your machine from crosswise slippage, keep the ramps free from oil, mud, debris, etc. The drum must also be free from extraneous matter that can cause slippage.
- Do not steer your machine on the ramps. If the machine is facing in the wrong direction, go back off the ramp, correct the direction and try again.
- Do not use kinked, twisted or damaged wireropes for crane or winch operation. Use ones with ample strength.
- When loading is complete, fix the machine with wooden blocks placed under the drums and chains fastened to the machine.

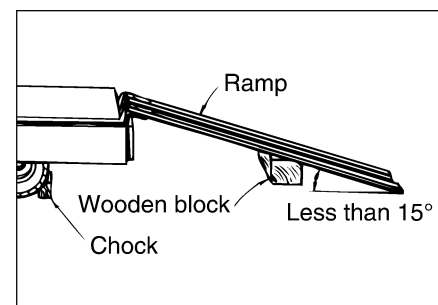

⚠ WARNING: Negligence of these instructions can lead to accidents.

1 BASIC PRECAUTIONS FOR SAFETY

1.7 Transportation

- Follow required regulations.
- Select a transporting route according to the overall width, overall height and gross weight of the trailer with the roller loaded.
- Know the maximum height clearance of the machine loaded on the transport trailer before hauling under bridges and other structures.

1.8 Handling the Battery

■ When handling the battery

- Battery electrolyte contains sulphuric acid. It will destroy clothing and skin. If it touches your clothing or skin, flush with large quantities of water.
- In case of eye contact, flush with clean water and get medical help.
- If swallowed, drink large amount of water, milk, beaten egg or vegetable oil, and get medical help.
- Wear safety goggles when handling the battery. Wear safety goggles, full face shield, rubber gloves and rubber apron when adding fluids to the battery.
- Keep cigarettes and flames away, and avoid recharging the battery in poorly ventilated places when there is a danger or generating sparks.



⚠ WARNING

Battery posts, terminals, and related accessories contain lead and lead compounds, chemicals known to the State of California to cause cancer and reproductive harm. Wash hand after handling.

- Inspect or handle the battery with the engine stopped and the starter switch in the OFF position.
- Turn the starter switch to the OFF position, then wait at least 30 seconds before removing the battery. An abnormality may arise in the ECM (engine control module).

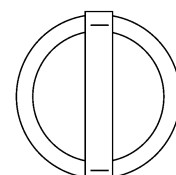
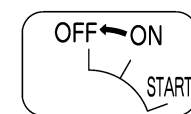

1 BASIC PRECAUTIONS FOR SAFETY

- Keep metallic items such as tools away from the battery terminals.
- Tangled terminals may generate sparks due to improper connections, resulting in the danger of explosions. Make sure terminals are connected firmly.
- The battery is for starting the engine and operating electrical equipment on the machine. Do not use it for any other purpose.
- Do not charge battery when the top surfaces of the liquids are at the LOWER level (the minimum liquid level) or below. Not only the internal parts of the battery are degraded and the battery lifetime are shortened but also it can cause explosions if you continue on using the battery when the top surfaces of the liquids are at the LOWER level or below. Immediately supply water until the water level is between the UPPER and LOWER levels.

■ Jump-starting the engine

- Wear safety goggles when jump-starting the machine.
- When starting from another machine, do not allow the two machines to make contact with each other.
- When connecting the battery cables, start with the positive terminal. For disconnection, start with the negative one.
- Do not allow a tool to bridge between the positive terminal and machine body. This can generate dangerous sparks.
- Do not connect the booster cable to wrong the terminal. Never connect the positive terminal to the negative terminal or the body of the machine.
- Final connection to the engine block of the disabled machine can cause sparks. The connecting point should be as far as possible from the battery.

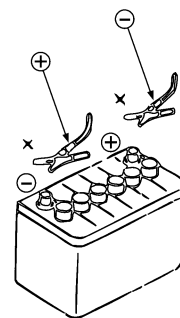

1.9 Towing

- Towing should only be carried out in emergencies and over short distances. A trailer should be used for long distance transport.
- The machine should not be operated while being towed.
- Follow the instructions in this manual to enable towing.
- Do not tow if the braking system has broken down, as it is dangerous.
- To tow the machine, use cables with ample strength.
- Do not perform towing on a slope.
- Be sure to attach a wire rope firmly to the towing hook.
- Do not use twisted, kinked or damaged cables when towing.
- Do not step over the wire rope.
- Keep everyone away from the space between the machine and the towing machine when connecting the two.
- Align the connection points of the disabled machine and the towing machine in a straight line when connecting the machines.

⚠ WARNING: Negligence of these instructions can lead to accidents.

1.10 Before Servicing

■ Attach warning tags when servicing the machine

- Serious accidents can occur if the machine is unexpectedly started or controls carelessly touched by an unauthorized person.
- Attach a warning tag at a clearly visible location in the operator's station and insure the key has been removed from the starter switch.



■ Setting the chocks

- Set chocks in front of and behind the roller drum (wheels) to prevent the machine from moving before beginning inspections or maintenance work.

■ Use proper tools

- It is very dangerous to use damaged or deteriorated tools or to use tools for other purposes than intended. Use correct tools for their intended use only.



■ Change safety-related parts at regular intervals

- Change any seatbelt found to be abnormal even if it is within its recommended service interval.
 - Change any ROPS found to be abnormal even if it is within its recommended service interval.
 - Replace fuel hose, high pressure hydraulic hoses and liquid hoses regularly to prevent fire. Replace high pressure hoses of the power steering system every two years.
- ☆ Change these parts at regular intervals even if found to be normal. They will deteriorate as time goes on.
- ☆ Change any hose found to be abnormal even if it is within its recommended service interval.

1 BASIC PRECAUTIONS FOR SAFETY

■ Inspect or service your machine with the engine stopped

- If required to keep the engine running in such a case as radiator interior cleaning, perform the work with two persons. One of them should sit on the operator's seat getting ready for shutting down the engine. He must take care not to touch any of controls carelessly. Maintenance personnel must exercise extreme caution not to make contact with moving parts.

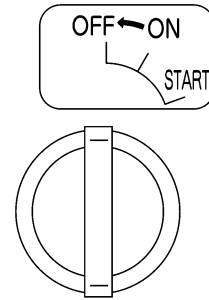

■ Supplying fuel, oils and grease

- Do not cover the filler port when refueling. Feeding fuel in an airtight tank might damage the fuel tank.
- Spilled fuel or oil will be slippery. Wipe up immediately. Keep the filler caps tight. Do not use fuel for flushing oil. Handle fuel and oil in a well ventilated area.

■ Check the coolant level in the radiator

- To check the coolant level, stop the engine and allow the engine and radiator to cool down before removing the radiator cap. Remove the cap by covering it with a rag before removing to prevent any fluid that could spray under pressure from causing a burn.

■ Illumination

- For inspecting the level of the fuel, oil, coolant and battery electrolyte, use explosion-proof illuminations. Failure to use this type of illumination can result in an explosion.



■ Make sure the gas dampers are properly maintained

- Before inspecting the engine room, make sure the gas dampers holding up the hood are firmly engaged. Furthermore, in machines with stays to prevent the hood from closing, make sure they are firmly in place.

■ Points to beware of when filling the sprinkler tank with water (on machine equipped with a sprinkler tank)

- Do not fill the tank with the water inlet blocked. It may damage the sprinkler tank.

⚠ WARNING: Negligence of these instructions can lead to accidents.

1 BASIC PRECAUTIONS FOR SAFETY

1.11 During Servicing

■ Keep unauthorized persons away

- During service, do not allow persons not concerned to enter the work area, particularly when grinding or welding operation is performed or heavy hammers are being used.



■ Assume an appropriate posture while working

- An unnatural posture during maintenance work may cause injuries. Assume a posture that is appropriate for the work being carried out.

■ Keep your machine clean

- Spilled oil, grease or scattered debris are dangerous. Always keep your machine clean. Moisture that penetrates into the electrical system can cause malfunctions. Do not use water to clean sensors, connectors and the operator's station.

■ Take care not to get caught or crushed

- Be sure to fix the hood and other covers after opening them to prevent closing and avoid getting caught in them.
- If there is a need to crawl under the machine after it has been lifted, be sure to support it from underneath with a solid prop or block.

■ When repairing the electrical system

- Read the warnings in this manual regarding the handling of batteries, and make sure to have a thorough understanding in order to handle them appropriately and safely.
- When repairing the electrical system or welding, disconnect the negative cable from the battery to shut off the electricity. Carrying out work while the cables are connected to the negative terminal may cause electrocution or explosions.



■ Carefully handle high pressure hoses

- Do not try to bend or hit hoses against a hard object. Do not use hoses or pipes that are bent or damaged. They will burst.
- Replace damaged fuel hose, hydraulic hoses and liquid hoses. An oil, hydraulic and liquid fluid spill can cause a fire.

1 BASIC PRECAUTIONS FOR SAFETY

■ Be careful of high pressure hydraulic fluid

- Bear in mind that the working equipment hydraulic systems are under internal pressure. Do not perform adding, draining, inspection or servicing of the hydraulic systems until the internal pressure has been relieved. Hydraulic fluid leaking through a fine hole at high pressure can penetrate your skin and eyes. Inspect leakage by holding a hard board close to suspected leaks wearing goggles. If affected by high pressure oil, get medical help immediately.

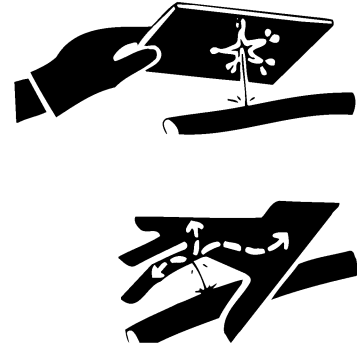

■ Be careful of hot parts

- After the machine has been operated for some time, the coolant, engine oil and hydraulic fluid will become hot.
- Removing the radiator cap or draining the coolant or oil can burn you. Perform this work in accordance with correct procedures after the systems have cooled down.



■ Use care when inspecting or servicing fan or belts in motion

- Do not wear clothing and accessories that tend to get caught in moving parts.
- Do not let your body or tools make contact with the fan blades or belts. They can be cut seriously.



■ Used oil disposal

- Do not throw used oil into a drain or waterway. Drain the oil from the machine into a proper container. Do not drain directly on the ground.
- Obey all local, state and federal environment regulations for the proper disposal of oil, fuel, coolant, battery electrolyte or any other fluids.

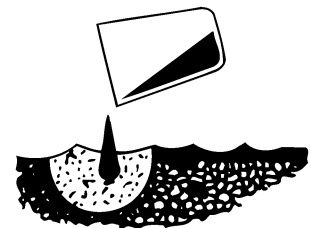

⚠ WARNING: Negligence of these instructions can lead to accidents.

1 BASIC PRECAUTIONS FOR SAFETY

■ Take care in handling the gas damper

- Never dismantle it.
- Do not throw it into a fire.
- Do not damage the rod.
- Do not bend the tube or rod, or use it as a handle.
- When disposing of it, be sure to fix the gas damper, and drill a hole around 2 to 3 mm in diameter, about 20 to 30 mm from the edge on the tube bracket side. Dispose of it after releasing the gas pressure. When doing this, be sure to wear protective goggles because of the danger of oil inside or swarfs getting sprayed everywhere by the compressed gas inside.

■ Exercise extreme care when replacing and repairing tires (Tire installed)

- Disassembly, repair and reassembly of tires require special facility and knowledge. Have them repaired at work shop specialized in handling tires.
- An improperly fitted tire can separate from the rim when inflating.
- When dismounting a tire, chock other tires for safety.
- When welding job is carried out near the tires, use extreme care, as this can cause an explosion of the tires.

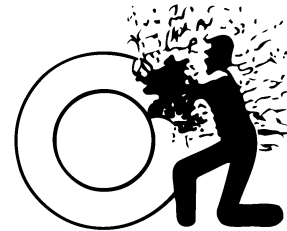

⚠ WARNING: Negligence of these instructions can lead to accidents.

1 BASIC PRECAUTIONS FOR SAFETY

1.12 Safety Decals

Keep all decals clean. If lost, replace with new one. There are decals other than those shown below: Treat them in the same manner as the one shown here.

① 3998-16491-2

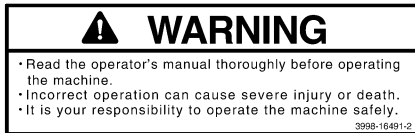

⑤ 3998-16500-0

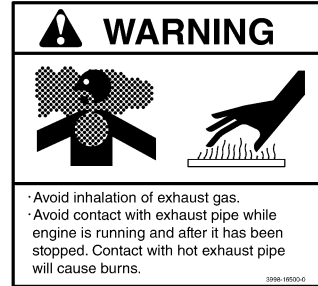

② 3998-16499-0 (2 locations)

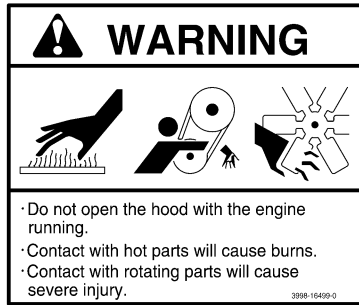

⑥ 3998-16502-0

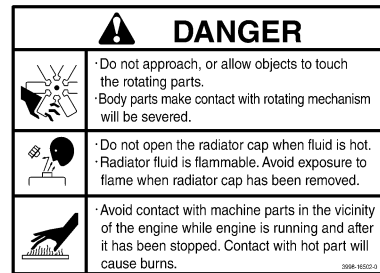

③ 3998-16501-0

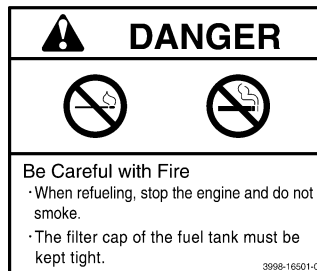

⑦ 3998-16681-1



④ 3998-16505-0

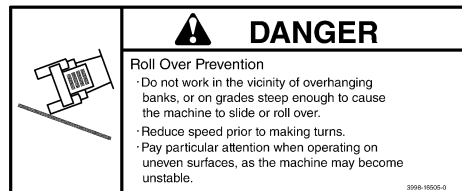

⑧ 3998-36002-0 (2 locations)



⚠ WARNING: Negligence of these instructions can lead to accidents.

1 BASIC PRECAUTIONS FOR SAFETY

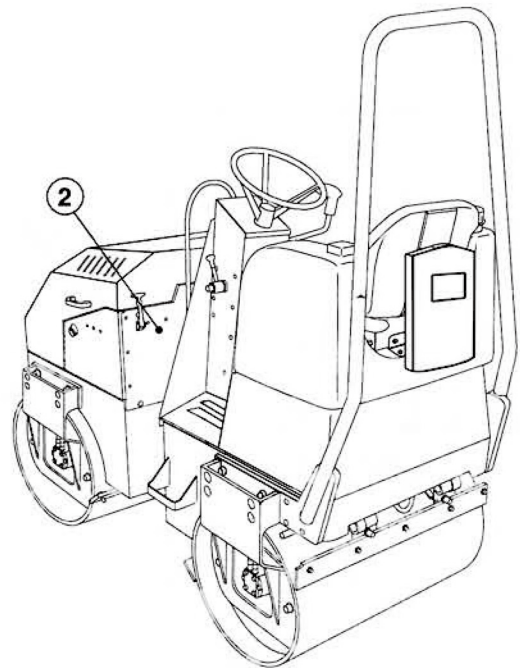
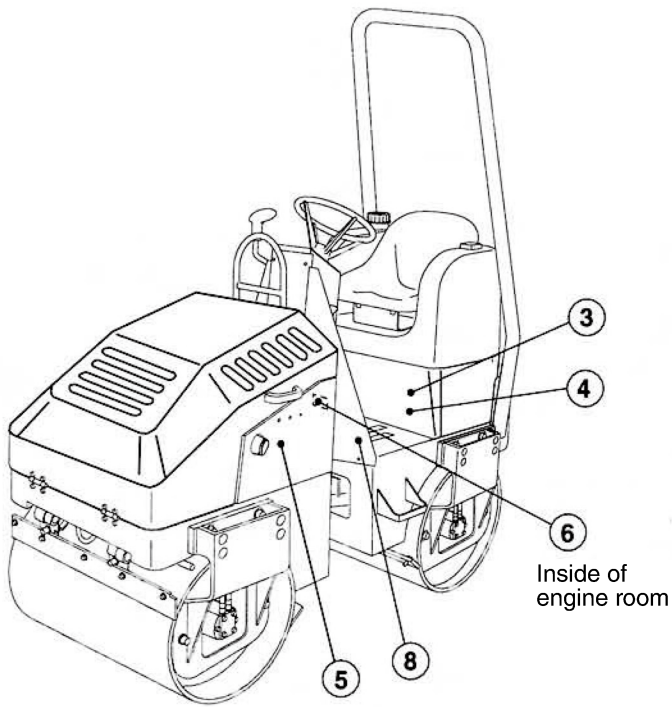
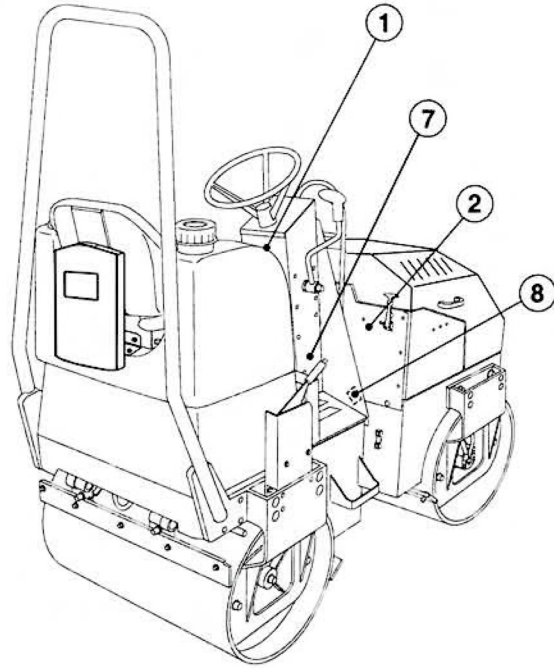

2 OPERATION

2.1 Instruments and Controls

2.1.1 Operator's station

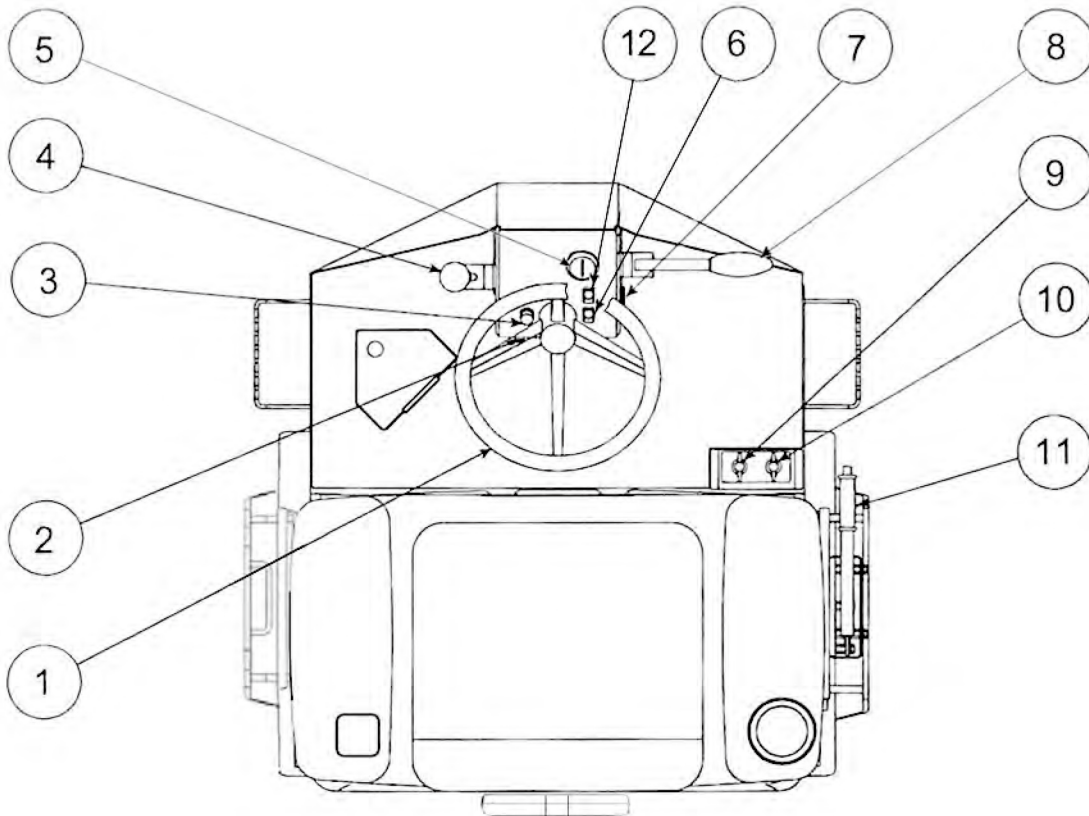

- | | |
|----------------------------|---|
| ① Steering wheel | ⑦ Hour meter |
| ② Choke knob | ⑧ Forward-Neutral-Reverse lever (F-N-R lever)
with vibrator switch |
| ③ Horn switch button | ⑨ Water control knob (Rear) |
| ④ Throttle lever | ⑩ Water control knob (Front) |
| ⑤ Starter switch | ⑪ Parking brake lever |
| ⑥ Engine oil pressure lamp | ⑫ Battery charge lamp |

2.1.2 Gauges and warning lamps

For safe execution of your job, fully understand the role and function of the systems involved.

Hour meter

Indicates total operating hours. The service interval recommendation in this manual should be based upon the hour meter readings.

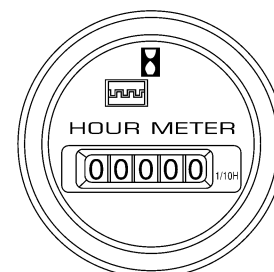

Engine oil pressure lamp

Goes on when engine lubricating oil pressure is lowered below specified value.

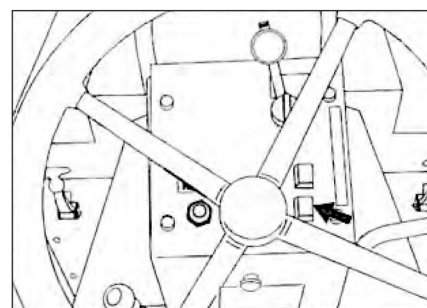

★ Warning lamp [Engine oil pressure lamp]

Go on when the starter switch is turned to the ON position and go off when the engine has started. If not, corresponding bulb burnt out.

If any of them lights up while engine is running, this indicates a faulty condition. Stop the engine and trace the source of trouble.

Battery charge lamp

Goes on when troubles have occurred in electric system while engine is running.

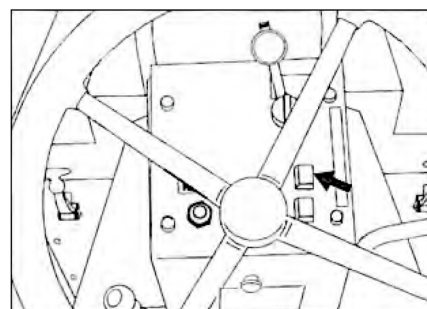

★ Warning lamp [Battery charge lamp]

Go on when the starter switch is turned to the ON position and go off when the engine has started. If not, corresponding bulb burnt out.

If any of them lights up while engine is running, this indicates a faulty condition. Stop the engine and trace the source of trouble.

2 OPERATION

2.1.3 Switches

Starter switch

Starts and stops the engine.

OFF : The key can be removed in this position. All the electric systems are switched off. To shut down the engine, move the key to this position.

ON : The charging circuit and lamp circuit are charged with electricity. Let the key stay in this position after the engine has started.

START: The engine is cranked and gets started. The moment the engine has started, release the key. It will automatically return to the ON position.

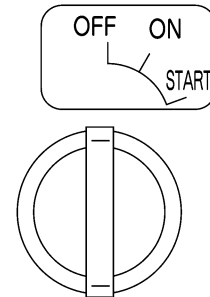

IMPORTANT

When the engine is cold, turn the key to the START position to start the engine, pulling the choke knobe. The choke knobe will return to the original position, if its hold is released.

Horn switch button

Pressing the button at the side of the steering wheel makes the horn sound.

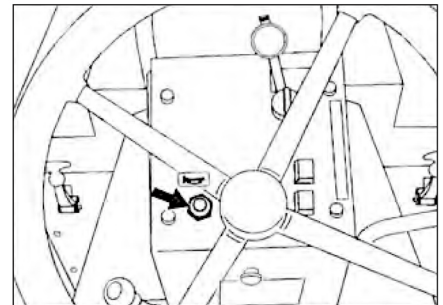

Vibrator switch

ON-OFF control of the vibrator is also made by the pushbuttons provided on the F-N-R lever. Press to work the vibrator. Press again to shut off vibration.

**IMPORTANT**

- Do not operate the vibrator on a hard area such as cement concrete pavement surface or the ground covered by thick steel sheets.
- Keep the vibrator stopped when the machine is at rest.
- Shut off the vibrator immediately when the machine has been caught in the mud during vibratory operation.

Disconnect switch (option)

ON position : Connect battery to the machine.
 OFF position : Disconnect battery to the machine.

When operating the machine, turn on the disconnect switch.

CAUTION

When servicing this machine or when not using for a long time, turn off the disconnect switch.

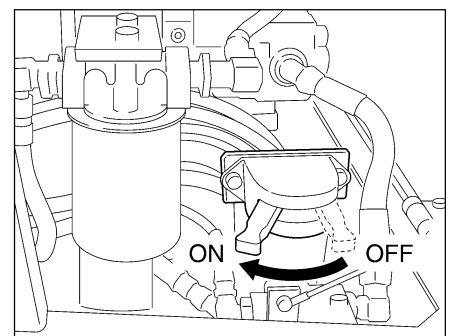
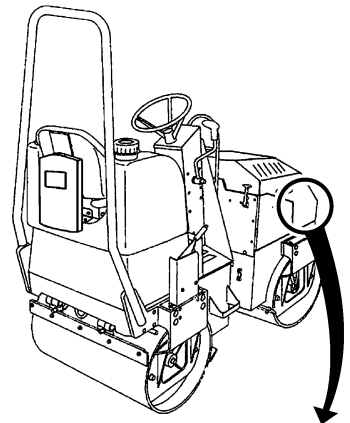

2 OPERATION

2.1.4 Operating levers and knob

Forward-Neutral-Reverse lever (F-N-R lever) with vibrator switch

Moving the F-N-R lever forward or backward makes the machine travel forward or backward respectively. The neutral position (N) brings the machine to a stop. The machine speed increases or decreases in proportion to the lever displacement.

The vibrator ON-OFF control is easily made by the F-N-R lever top vibrator switch (refer to page 27).

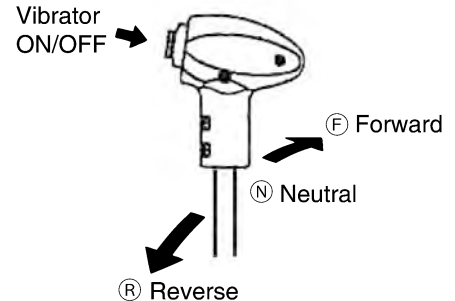

⚠ CAUTION

To start the engine again, set the F-N-R lever to neutral and get starting after securing safety.

Throttle lever

Shifts the engine RPM. The engine RPM increases when moved toward the operator.

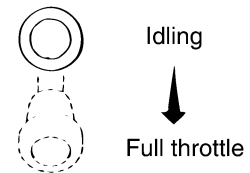

Parking brake lever

To apply the parking brake, pull the lever up. To release the brake, press the lever-top button and push the lever down.

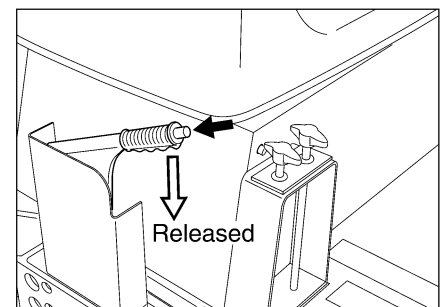
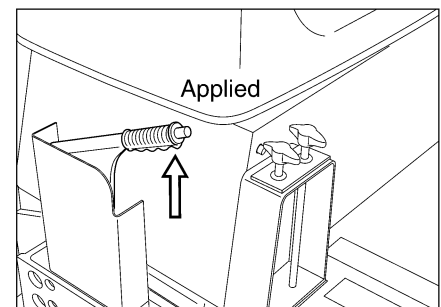

⚠ WARNING

When dismantling from the machine, pull up the lever without fail to apply the brake.

Unloader lever

The unloader lever disengages the drive, playing a role like a clutch. Use this lever for towing the machine when the engine is disabled or when troubles have developed in the hydraulic drive.

For towing:

Turn the unloader lever counterclockwise (Unload).

For normal traveling:

Turn the unloader lever clockwise (Onload).

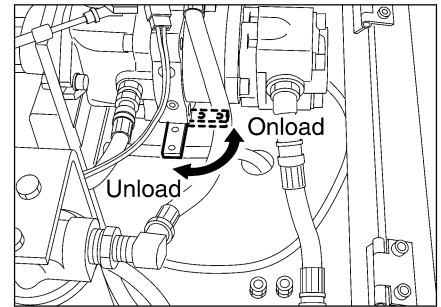

⚠ WARNING

- On a slope, chock the wheels and use extreme care when handling the unloader lever and towing the machine.
- Be sure to apply the parking brake when operating the unloader lever.

NOTE: For normal travel, be sure to hold the lever in the ONLOAD position.

Choke knob

When the engine is cold, pull the choke knob.

While pulling the choke knob, choke closes.

If its hold is released, the choke knob will return and choke will open.

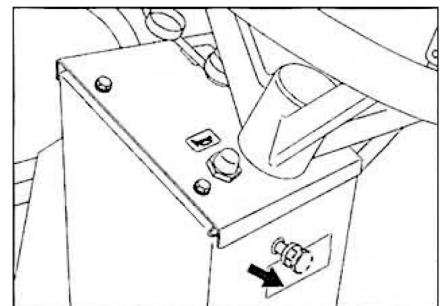

Water control knob (Front)

Water control knob (Rear)

Turn On / Off the water control knob for each of front and rear rolls.

Turn it clockwise to start sprinkling of water and counterclockwise to stop it.

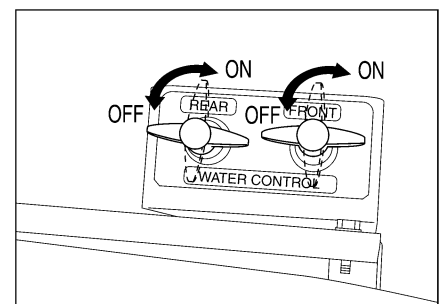

2 OPERATION

2.1.5 Fuse

⚠ WARNING

When changing a fuse, cut the power supply by turning the starter switch to the OFF position.

Fuses protect electrical components and wiring from burning. Be sure to use fuses of correct capacity consulting the electric wiring diagram (refer to page 64).

2.2 Handling and Adjustments

2.2.1 Scraper adjustment and replacement

1) Clearance adjustment of blades (a)

- ① Loosen fixing bolts (b) at 2 locations.
- ② Loosen nuts (c) . Slide blades (a) until they make contact with the drum. Retighten nuts (c) .
- ③ For fine adjustment, turn set bolt (b) .

2) Replacement of scraper blades

- ① Remove bolts (d) .
- ② Replace blades (a) with new ones.
- ③ Refit and retighten bolts (d) .

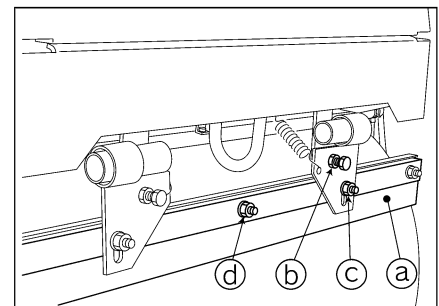

2.3 Operation

⚠ WARNING

- This machine is a one-man roller.
- Operate the machine from the operator's seat.
- Be sure to wear the seatbelt during operation (with seatbelt).

2.3.1 Before-starting inspection

- 1) Check that the steering lock pin is in the carrying position.

⚠ WARNING

Make sure that the steering lock pin is connected in the carrying position before putting the machine in motion. Steering is impossible if the pin is in the steering lock position.

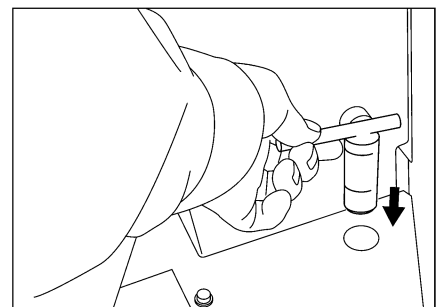
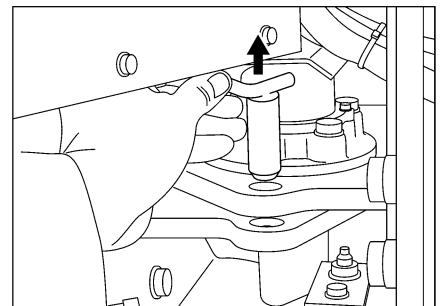

NOTE: Return the lock pin to its storage position on the floor board of the operator's seat.

- 2) Check that the F-N-R lever is in the neutral position (N).

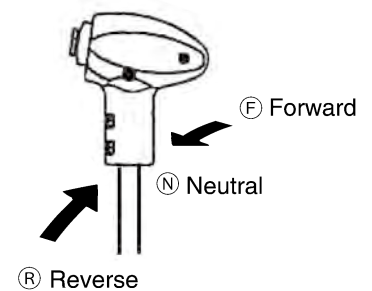

NOTE: The engine does not start if the F-N-R lever is not in the neutral position (N).

2 OPERATION

2.3.2 Starting the engine

⚠ WARNING

Check that the F-N-R lever is in the neutral position (N), and sound the horn when starting the engine after making certain that there are no one and no objects close to the machine.

- 1) Set the throttle lever in a position slightly higher than IDLING.

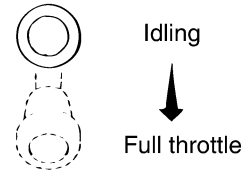

- 2) Turn the starter switch to the ON position and check that the engine oil pressure lamp are on.

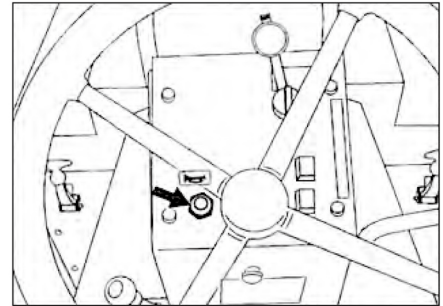

- 3) In cold weather, start the engine while pulling the choke knob.

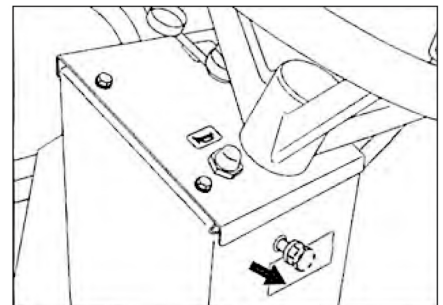

- 4) Turning the key to the START position makes the engine start. Release the key the moment the engine has started. The key will automatically return to the ON position.

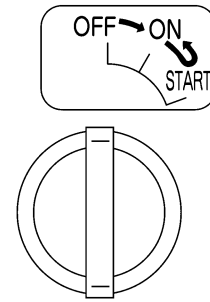

⚠ CAUTION

- Do not allow the starter key to stay in the START position for more than 5 seconds.
- If the engine does not start, allow an interval of 15 seconds before trying again.
- Check that the warning lamps on the engine oil go off immediately after the engine is started. If any of these warning lamps becomes bright while the engine is running, shut down the machine, determine the cause and rectify the fault.

2.3.3 After starting the engine

Try not to move to operation immediately after starting but observe the following:

IMPORTANT

Avoid increasing the engine speed abruptly before warming-up run is completed.

- 1) Run the engine at idle for about 5 minutes to warm it up. Warming-up run allows the lubricating oil to reach the vital parts of the engine and hydraulic system, while gradually bringing up the engine oil and hydraulic oil to the working temperature.
- 2) After the warm-up operation, check that:
 - Engine oil pressure lamp Has gone off.
- 3) Check for the color of exhaust gas, listen for unusual sounds and vibration. If abnormal, determine the cause and correct the problem.

2 OPERATION

2.3.4 Traveling

⚠ WARNING

- When starting, operate the horn after securing the safety around the machine. Clear away obstacles on the road.
- Be sure to wear the seatbelt during operation (with seatbelt).

⚠ CAUTION

While travelling, do not turn the starter switch OFF.

- 1) Speed up the engine by pulling the throttle lever towards you.

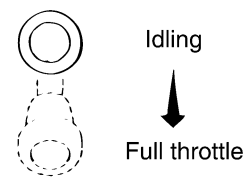

- 2) Release the parking brake.

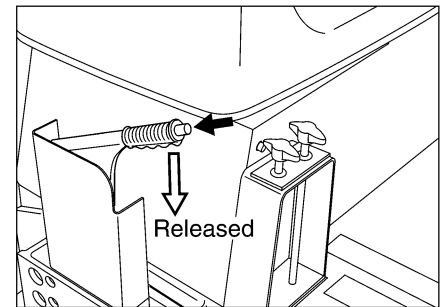

- 3) Move the F-N-R lever in the direction to travel, and the machine will begin traveling.

⚠ CAUTION

- Avoid abrupt operation of the F-N-R lever.
- Pay extreme attention to the area behind the machine when backing, since the space just behind it tends to be a blind spot.

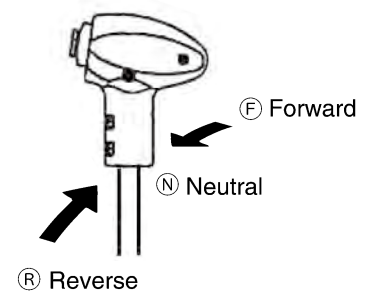

NOTE: The travel speed can be controlled by the throttle lever and F-N-R lever.

2.3.5 Stopping / Parking

⚠ WARNING

- Avoid abrupt braking. Try to leave enough time for braking.
- Avoid parking on a grade.
- If necessary to park on a grade, block the wheel to prevent unexpected moving down the grade.

1) Bring the F-N-R lever to the neutral position (N) , and the machine will come to a halt.

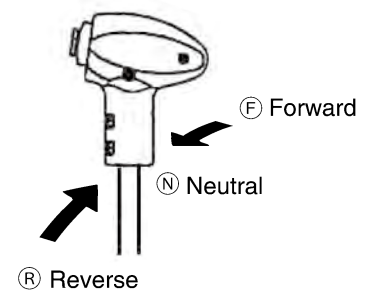

2) Pulling the parking brake lever for braking.

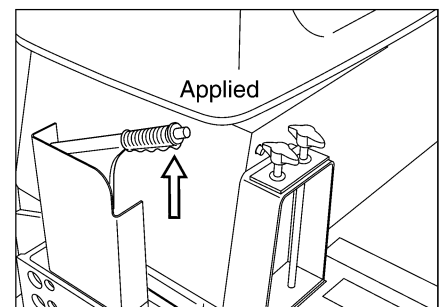

2.3.6 Stopping the engine

1) Gradually cool down the engine at low idling for about 5 minutes with the throttle lever in the idling position.

IMPORTANT

- Do not bring a hot engine to a sudden stop except for an emergency. This will shorten the life of its component parts.
- Do not also allow an overheated engine to come to a sudden stop, but run it at middle idling speed for gradual cooling down.

2 OPERATION

- 2) Turn the starter key to the OFF position to stop the engine.

⚠ CAUTION

Do not turn the starter switch OFF while the machine is in motion.

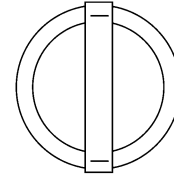
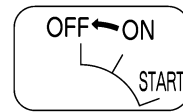

- 3) Pull off the starter switch key.

⚠ WARNING

- When dismounting from the machine, apply the brake by pull the parking lever. If necessary to park on a grade, block the wheels to prevent unexpected moving down the grade. Never fail to remove the starter key.
- Remove the starter switch key.

2.3.7 Check after stopping the engine

- 1) Perform the walk-around checks for oil and water leakage, abnormal signs around the drums.
- 2) Fill the fuel tank.
- 3) Remove waste paper if any from the engine compartment, as this will pose a possible fire hazard.
- 4) Scrape mud or other materials from and around the drums.

2.4 Vibratory Operation

- 1) Run the engine at full throttle by pulling the throttle lever toward you.

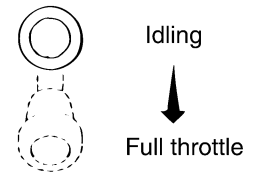

- 2) Press to work the vibrator on the switch of F-N-R lever. Press again to shut off vibration.



- 3) Proper travel speed for vibratory compaction is 2 – 5 km/h, however, select speeds depending upon job requirements.

⚠ CAUTION

- **Keep the vibrator shut off when the machine is not rolling.**
- **Stop vibration if the machine has encountered a running difficulty, for example, when it gets stuck in the mud.**

2 OPERATION

2.5 Sprinkler

- 1) Before sprinkling, check for the water level in the sprinkler tank by taking off the filler cap. Add water as necessary.

IMPORTANT

Use clean water wherever practicable.

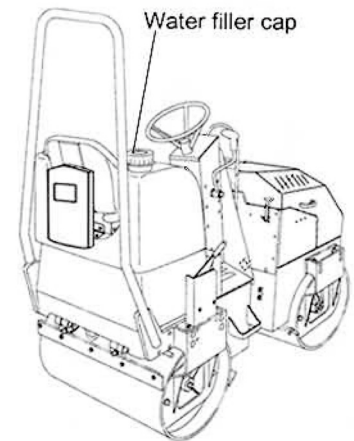

Sprinkling on the front drum only or rear drum only.

Before sprinkling, close the sprinkler knob located at the right lower part under the operator's seat.

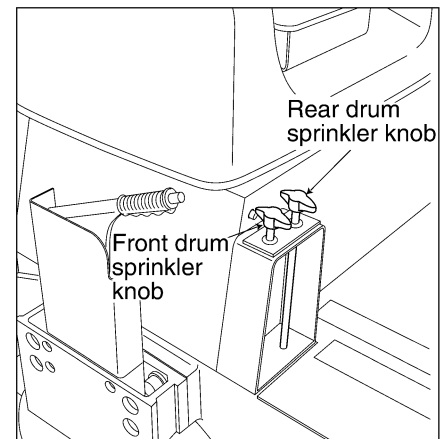

- 2) Turn the knob clockwise to start sprinkling of water and counterclockwise to stop it.

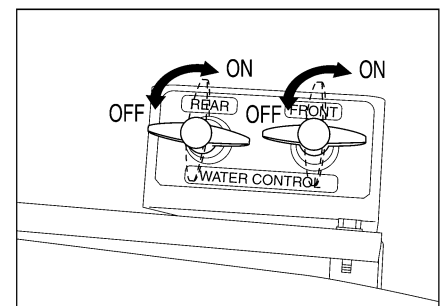

To drain water:

- ① Turn sprinkler tank drain cap (a) counterclockwise and completely drain the tank.
- ② After completion of draining, leave all cocks open.

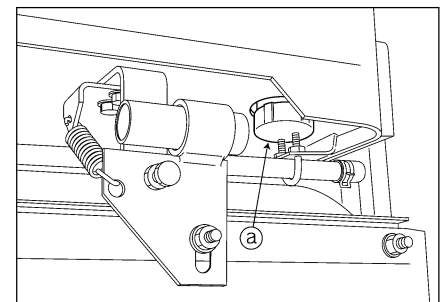

2.6 Precautions for Work

2.6.1 Compaction operation

■ Do not operate the vibrator on hard location

- Do not work the vibrator on a hard surface such as concrete pavement, as this can cause the machine to jump and give abnormal shock load. Damage to shock isolators will result.

■ Change the direction of travel gently

- When changing the direction of travel during asphalt mix compaction, slowly shift the F-N-R lever.

2.6.2 When going downhill

■ Use the F-N-R lever

- Run slowly by the operation of the F-N-R lever even if the travel distance is short.

■ Use the engine brake

- Go downhill by applying the engine brake along with the F-N-R lever operation.

2.6.3 On a slope

■ Working on a sidehill

- Work in an uphill / downhill direction, and avoid working on sidehill with the machine inclining sideways.

2.7 Applicable Jobs

The machines do a variety of jobs as listed below.

They most effectively handle works or materials marked ★ .

Work

★ Asphalt road paving

- Dust removal treatment for road
- Road improvement
- Embankment construction
- Dam construction

★ Construction of forestry and farm roads

- Foundation building
- Construction of sidewalk, shoulder and gutter foundation

Material to be compacted

- ★ Asphalt pavement
 - Crusher run
 - Cement concrete
- ★ Sands
 - Soils
 - Slag
 - Soft rock

Layers to be compacted

- ★ Surface course, Binder course
- ★ Base course
 - Subgrade
 - Embankment
 - Shoulder
- ★ Sidewalk

2.8 After Operation

Check for the fuel level.

Follow the procedures below to prevent the machine from falling into an unworkable condition the following morning caused by muds and other extraneous matter on the drum, or frozen drums:

- 1) Remove muds and water from the machine. Muds can get into the seals together with water drops on the hydraulic cylinder piston rod. Damaged seals will result.
- 2) Park the machine on a hard and dry surface. If such a place is not available, cover the ground with hard plates.
- 3) Low temperature will cause a significant reduction of battery efficiency. Cover batteries or take them off from the machine and store in a warm place for the following day's operation.
- 4) To avoid freezing, fully drain the sprinkler tank, pipes and filter in cold weather (refer to page 38).

IMPORTANT

- **Drain water completely from the sprinkler system, as remaining water can cause damage to the system.**
- **Do not pressure clean around the instrument panel or the back side of the dashboard.**

2.9 Loading and Unloading

⚠ WARNING

- Use sturdy ramps with proper width, length and thickness which allow safe loading and unloading.
- If the ramps deflect considerably under load, apply wooden blocks to reinforce them.
- Loading should be conducted on a level and hard ground. Leave a sufficient distance between the machine and the shoulder.
- To prevent slippage on the ramps, keep the drums free from mud, oils, etc. The ramps must also be free of grease, oil and ice.
- Do not steer the machine on the ramps. If the machine is facing in the wrong direction, allow it to dismount from the ramps and correct the direction.

For loading and unloading, use ramps or a proper loading stand.

2.9.1 Use of a truck or trailer equipped with a winch

⚠ WARNING

Placing the unloader in UNLOAD position disrupts the power for traction. Do not enter the areas ahead of and behind the machine. It is very dangerous.

1) Engage the truck or trailer brake and chock its wheels. Fix the ramps so that the machine and truck or trailer are completely aligned.

- ☆ The angle between the ramps and ground must be less than 15 degrees.
- ☆ Leave a proper space between the ramps according to the width of the roller drum.

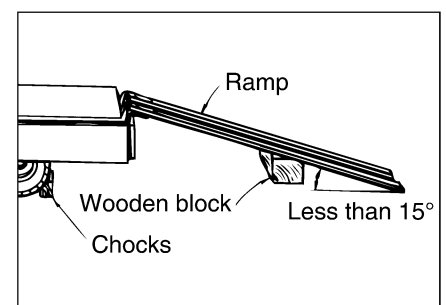

2) Decide the correct direction of run and make the machine run forward to the ramps.

2 OPERATION

- 3) Draw the wire rope from the truck or trailer winch and put its hook on the hooking point ① or ② .
- 4) Place the unloader lever located inside the engine compartment to the UNLOAD position (refer to page 29).
- 5) With the engine running at idle, perform loading by means of the truck or trailer winch.
- 6) When the loading is completed, set the unloader lever back in the ONLOAD position.
- 7) Locate the machine correctly on the truck or trailer.

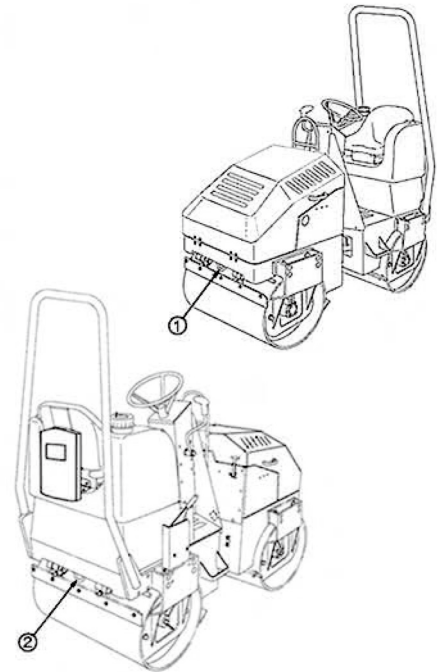

2.9.2 Self-propelling

- 1) Engage the truck or trailer brake and chock its wheels. Fix the ramps so that the machine and truck or trailer are completely aligned.

☆ The angle between the ramps and ground must be less than 15 degrees.

☆ Leave a proper space between the ramps according to the width of the roller drum.

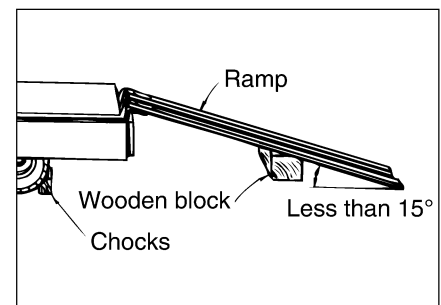

- 2) Decide the correct direction of run and conduct loading or unloading at low speed.

For loading, run forward at low speed.

For unloading, run backward at low speed.

- 3) Locate the machine correctly on the truck or trailer.

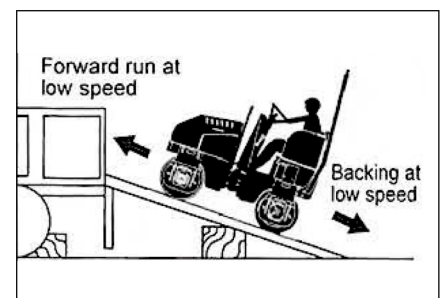

2.9.3 Use of a mobile crane

⚠ WARNING

- When lifting, use sturdy wire ropes.
- Before lifting, lock articulation by means of lock far located by the center pin.
- Keep your body out of the frame faces to prevent a pinch.

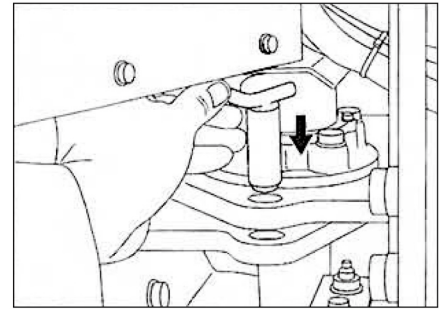

- 1) Before starting to work, the mobile crane operator must check the crane for normal working condition in accordance with the prescribed check list.
- 2) The slinging worker must check wire ropes to see if they are in normal condition to use.
- 3) When loading and unloading, set the outrigger on both sides of the crane securely, and use thick wooden or steel sheets to provide a firm footing.
- 4) The trailer driver must apply the parking brake positively and chock the wheels to secure machine stability.
- 5) The mobil crane operator and slinging worker should work together strictly observing hand signals.
- 6) Put the wire rope hook on the hooking point of the roller, carefully perform loading or unloading securing the ballane of the roller.
- 7) Slowly conduct loading and unloading being careful not to allow the roller to make contact with the wire ropes on other lifting gears.
- 8) Locate the machine correctly on the trailer.

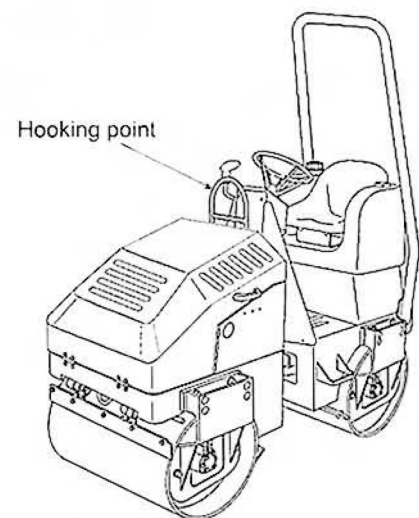

2.10 After Loading the Machine

When the machine has been located properly on the trailer, tie it down as follows:

- 1) Pull the parking brake lever to apply the parking brake. Place wooden blocks under the drums to prevent movement.
- 2) Fix the machine with ropes tied at the front and rear towing hook holes. Particularly, pay attention to sidewise skidding.

2.11 Transportation

⚠ WARNING

To decide the transporting route, check the width of the road, height and weight (including the roller) of the trailer. Obey relevant regulations.

For transportation, obey traffic regulations.

2.12 Operation in Cold Weather

In cold weather, take the following measures to prevent troubles such as starting difficulty and coolant freeze-up.

2.12.1 Fuel oil and grease

Use fuel and oil with low viscosity (refer to page 62).

2.12.2 Battery

⚠ WARNING

- **Batteries generate explosive gases. Do not use an open flame close to batteries.**
- **The battery electrolyte is corrosive. Keep the electrolyte away from your eyes and skin. If you are affected by the electrolyte, flush with large quantities of water and get medical help.**

When the temperature decreases, the battery capacity will lower, possibly freezing the electrolyte.

Keep the battery in a satisfactory condition at all times, and pay attention to heat insulation for satisfactory start-up on the next morning.

The hydrometer atop the battery permits confirmation of the condition of the battery.

- Green Satisfactory
- Black..... Charging is necessary
- Semitransparent... Replacement is necessary

2.13 When the Cold Season is Over

When winter is over and the warm season has come, proceed as follows:

- 1) Change oil and fuel with those of specified viscosity rating in accordance with manufacture's recommendation.
- 2) If AF-PT antifreeze is in use, drain the coolant completely, wash clean inside the cooling system, and then fill with non-amine type long-life coolant.

2.14 For a Long Storage Period

For leaving the machine unused for longer than one month, proceed as follows:

- 1) Store the machine in a closed area after cleaning.
- 2) Conduct oiling, greasing and changing of oil.
- 3) Grease lubricate the exposed portion of hydraulic cylinder piston rods.
- 4) Cover the battery after disconnecting the negative cable or take off the battery from the machine and store in a safe place.
- 5) If the temperature is expected to go down below 0°C, add antifreeze to the coolant.
- 6) Completely drain the sprinkler water.
- 7) Place the F-N-R lever in the neutral position (N) , turn the vibrator off and apply the parking brake.
- 8) Chock the machine.
- 9) Remove the starter switch key.

2.15 During the Storage Period

⚠ WARNING

If necessary to operate the machine for anti-corrosive purpose in closed area, ensure good ventilation keeping windows and doors open to prevent gas poisoning.



During storage, operate the machine at least once a month to prevent the oil films on the lubricated parts from deteriorating and to charge the batteries.

2.16 When the Battery Has Discharged

⚠ WARNING

- To check and handle the batteries, keep the engine stopped with the starter switch in the OFF position.
- The batteries give off explosive gases. Do not smoke close to the batteries. Keep flames and sparks away from the batteries.
- The electrolyte is very corrosive and will harm your clothing or skin. If the electrolyte has come into contact with your clothing or skin, flush with sufficient amount of water. In case the electrolyte has gotten into your eyes, flush with water and get medical help.
- To disconnect the battery cables, start with the negative terminal (earth). When connecting, start with the positive terminal. Do not allow a metallic item to bridge between the positive terminal and machine body. This can generate sparks, causing an explosion.
- Loose battery terminals can cause sparks. An explosion will result. When connecting the terminals, make certain that they are tight.

Disconnect with negative cable first

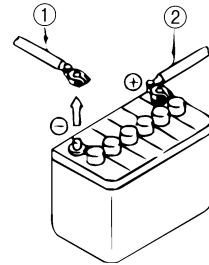

Connect with positive cable first

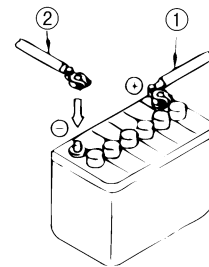

⚠ CAUTION

The power-supply voltage of this machine is 12 V.

2.16.1 Connection and disconnection of booster cables

When jump-starting the engine, connect the booster cables as follows:

■ Connection of booster cables

- 1) Connect one end of the positive booster cable (A) to the positive \oplus terminal of the battery on the machine.
- 2) Connect the other end of the positive booster cable to the positive \oplus terminal of the booster supply.
- 3) Connect the negative booster cable (B) to the negative \ominus terminal of the booster supply.
- 4) Connect the other end of the negative booster cable to a good earth of the engine block of the machine.

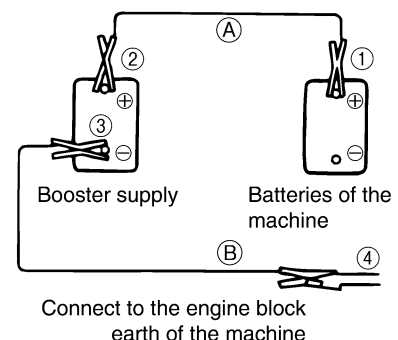

■ Disconnection of booster cables

- 1) Disconnect the negative booster cable (B) from the engine block earth.
- 2) Disconnect the negative booster cable (B) from the booster supply.
- 3) Disconnect the positive booster cable (A) from the booster supply.
- 4) Disconnect the positive booster cable (A) from the machine.

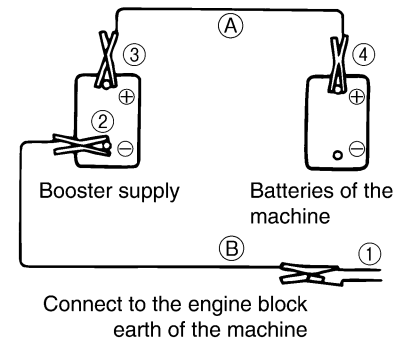

⚠ WARNING

- Do not allow the positive \oplus terminal to make contact with the negative \ominus terminal when connecting the booster cables.
- Wear safety goggles when jump-starting the engine.
- Do not allow the machine to make careless contact with the booster supply.
- Do not make wrong connections. Connect the negative \ominus cable to the engine block earth far away from the battery, as sparks may occur when connecting.

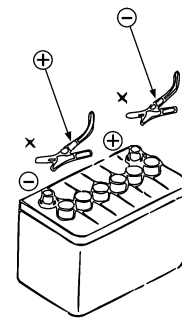

⚠ CAUTION

- Use booster cables and end clips of proper size suited to the battery capacity.
- Use the batteries of the equal capacity for the machine and booster supply.
- Check booster cables and end clips for signs of damage and corrosion.
- Connect the clips positively.
- The power-supply voltage of this machine is 12 V.

3 PERIODICAL MAINTENANCE

3.1 Precautions

Whether or not the inspection service and lubrication are performed at the correct regular intervals exerts significant influence on the occurrence of trouble and service life of the machine. In this manual, typical intervals for inspection and service are given. However, flexibility should be introduced as to interval or type of services to enable your machine to always operate in the best condition.

General precautions:

- 1) Always use SAKAI genuine parts for replacement.
- 2) Use lubricants recommended by SAKAI. Avoid mixing different brand lubricants.
- 3) For hydraulic oil replenishment, changing, level checking, filter cleaning or replacement, oiling and greasing, use extreme care to prevent dust from entering.
- 4) For checking oil level or changing oil, park the machine on a level and hard surface.
- 5) Change oil while its temperature remains high after operation.
- 6) For a long-term storage, fill the fuel tank, lubricate necessary points and run the machine for more than 20 minutes once a month.
- 7) For the hydraulic pump and motor, have them serviced at authorized service shops.
- 8) Turn the starter switch OFF when performing services such as repairing broken wires, short circuits and tightening loose terminals.

▲ CAUTION

- **With a new machine, change the engine oil (refer to page 53) and change the engine oil filter cartridge (refer to page 53) after 50 hours of operation for the first time only.**
- **When trouble occurs in the engine oil level by the indicator lamp on the control panel, sensor will work and corresponding lamp comes on. If this occurs, conduct necessary service regardless of the periodical service interval recommendation.**
 - 1) **Engine oil warning lamp ⇨ Add engine oil as necessary**
- **Check the electric wiring at a regular interval not exceeding one month:**
 - 1) **Damage to the wire harness and loose clamps**
 - 2) **Loose sockets**
 - 3) **Function of electrical systems**

3.2 Walk-around Checking

For efficient operation, daily, before-operation checking is very important. Before starting, perform walk-around checking for loose bolts, nuts and signs of leakage in addition to items as shown below:

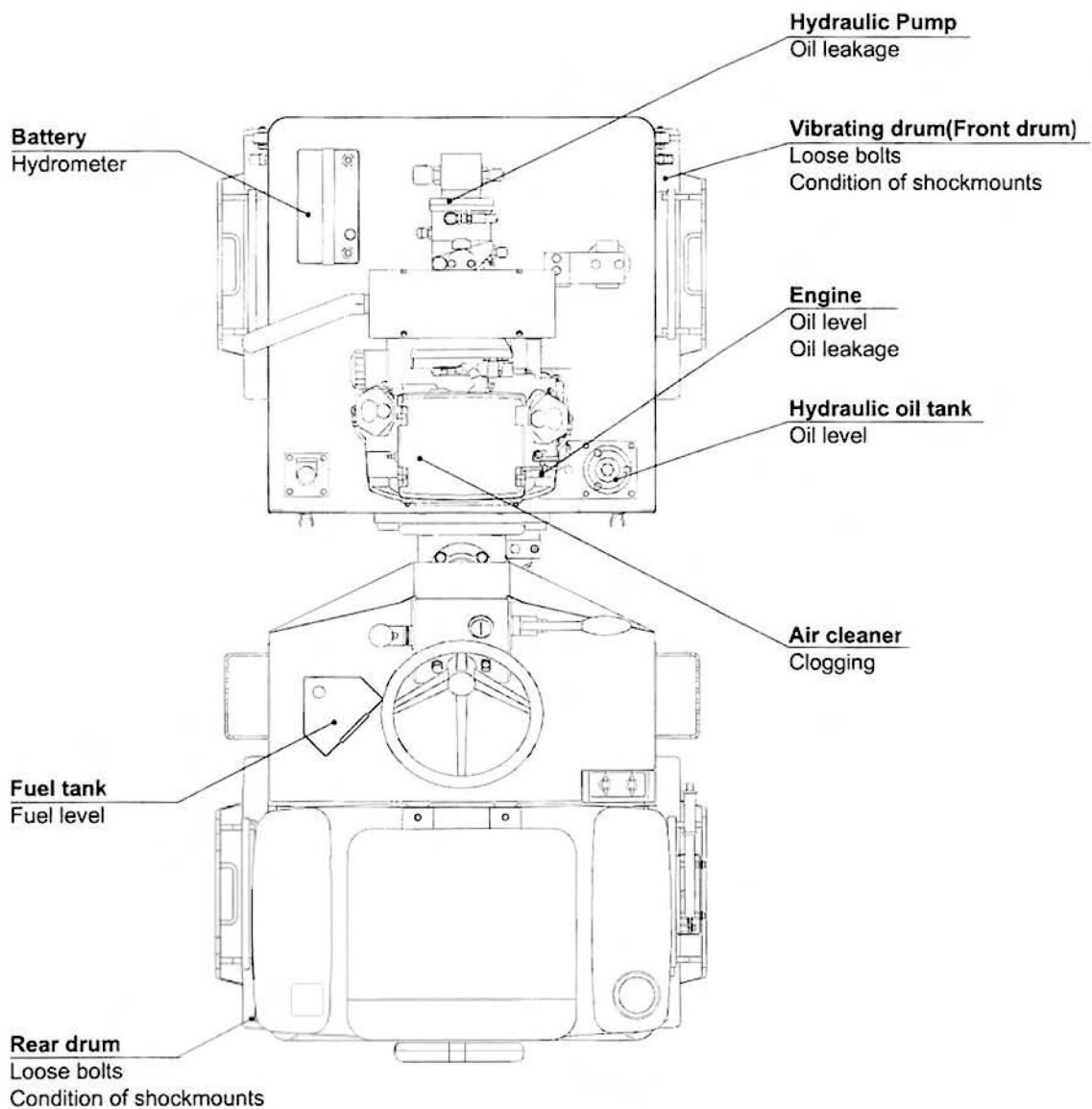

3.3 Periodical Maintenance Points

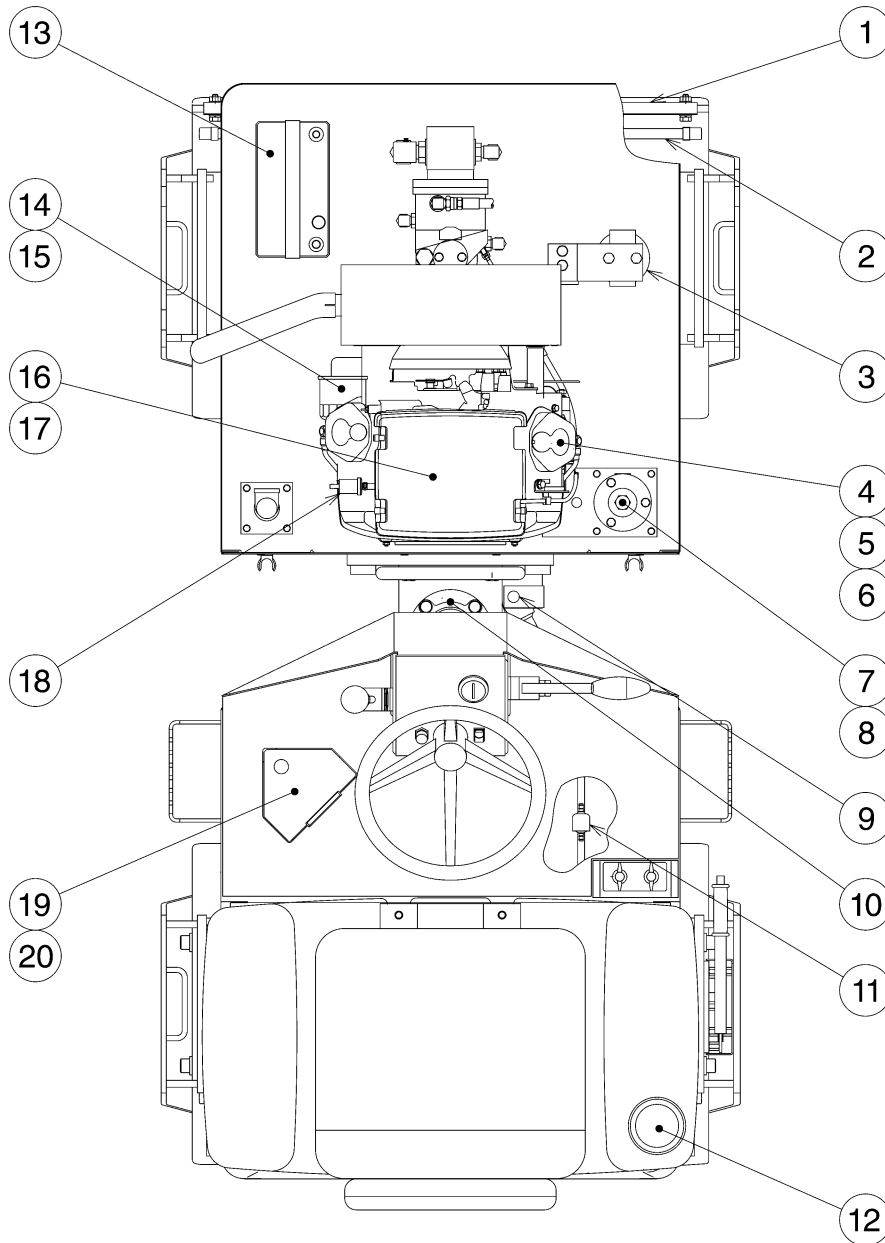

3 PERIODICAL MAINTENANCE

Interval	Sym- bol	Item	Service	Lubricant	Q'ty
Every 10 hours or daily	④	Engine oil pan	Check oil level, add as necessary	Engine oil	1
	⑱	Fuel tank	Check fuel level, add as necessary	Gasoline	1
First 20 hours	⑤	Engine oil pan	Change oil	Engine oil	1
First 50 hours	⑭	Engine oil filter	Change element		1
Every 50 hours	⑦	Hydraulic oil tank	Check fuel level, add as necessary	Hydraulic oil	1
	⑨	Cylinder pin	Apply grease	Grease	2
	⑩	Center pin	Apply grease	Grease	2
Every 100 hours	⑥	Engine oil pan	Change oil	Engine oil	1
	⑬	Battery	Check looseness of mounting and terminal		1
Every 200 hours	⑮	Engine oil filter	Change element		1
Every 300 hours	⑪	Fuel strainer	Change element		1
	⑱	Fuel strainer	Change element		1
Every 500 hours	③	Line filter	Change element		1
	⑧	Hydraulic oil tank	Change element, wash inside	Hydraulic oil	1
	⑯	Air cleaner	Change element		1
As required	①	Scraper	Adjust or change blade		4
	②	Sprinkler pipe	Clean or change		2
	⑫	Sprinkler tank	Clean inside		1
	⑰	Air cleaner	Check or clean element		1
	⑳	Fuel tank	Clean inside		1

3.4 Maintenance Procedure

➔ For servicing the engine, see the separate engine manual.

(1) Every 10 hours or daily

④ Engine oil pan

Check the engine oil level with the engine shut down. Add the engine oil from the fill port if the level is not within the permissible range (MAX – MIN).

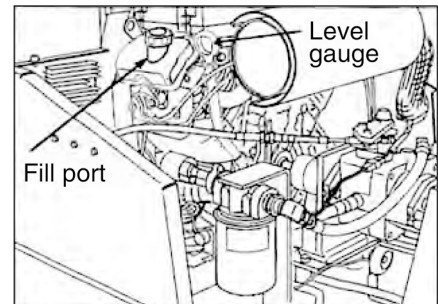

⚠ CAUTION

Be sure to use engine oil recommended by SAKAI (refer to page 62).

⑱ Fuel tank

Check the fuel level with the fuel gauge or the level gauge. Add as necessary fill port.

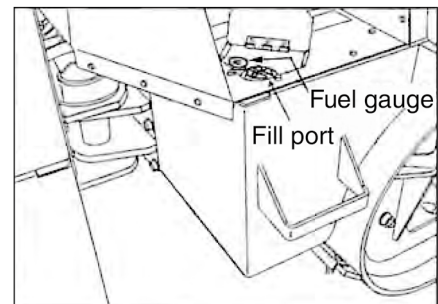

⚠ CAUTION

- For refueling, park the machine on a level and solid surface.
- Be sure to use fuel recommended by SAKAI (refer to page 62).

(2) First 20 hours

⑤ Engine oil pan

- 1) After completion of operation and while the oil is warm, drain the oil with the drain plug removed.
- 2) Refit the drain plug and fill the crankcase with the engine oil from the fill port.



⚠ WARNING

When draining a hot oil, use care not to get burned.

⚠ CAUTION

Be sure to use engine oil recommended by SAKAI (refer to page 62).

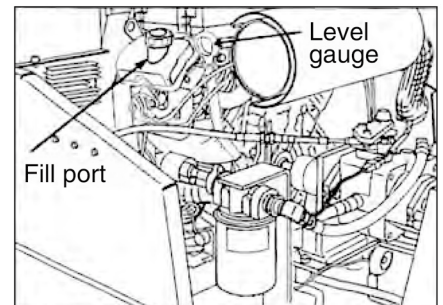

(3) First 50 hours

⑭ Engine oil filter

➔ **See the separate engine manual.**

- 1) After completion of operation and while the oil is warm drain the oil with the drain plug removed.

⚠ WARNING

When draining a hot oil, use care not to get burned.

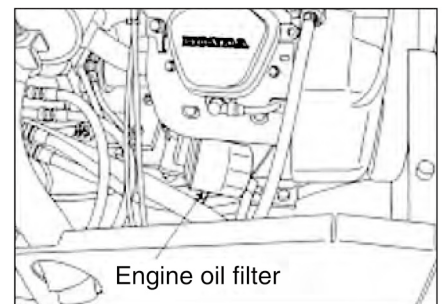

- 2) Refit the drain plug and fill the crankcase with the engine oil from the fill port.
- 3) Change the oil filter cartridge.

⚠ CAUTION

Be sure to use engine oil recommended by SAKAI (refer to page 62).

3 PERIODICAL MAINTENANCE

(4) Every 50 hours

⑦ Hydraulic oil tank

Check the oil level with the sight glass on the side of tank.
The level is proper if it is between H and L marks.
If necessary, add the hydraulic oil from the fill port.

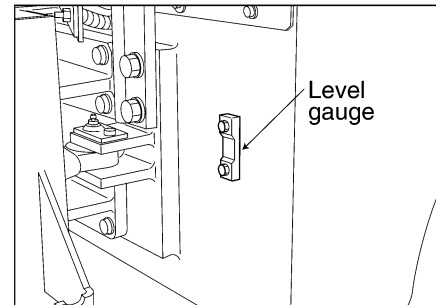

⚠ CAUTION

Be sure to use hydraulic oil recommended by SAKAI (refer to page 62).

⑨ Cylinder pin

Grease the fittings.

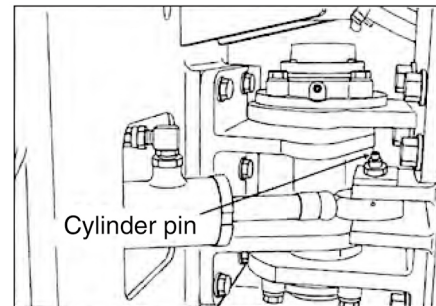

⚠ CAUTION

Be sure to use grease recommended by SAKAI (refer to page 62).

⑩ Center pin

Grease the fittings.

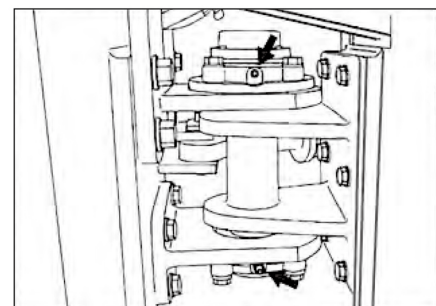

⚠ CAUTION

Be sure to use grease recommended by SAKAI (refer to page 62).

(5) Every 100 hours

⑥ Engine oil pan

- 1) After completion of operation and while the oil is warm drain the oil with the drain plug removed.
- 2) Refit the drain plug and fill the crankcase with the engine oil from the fill port.

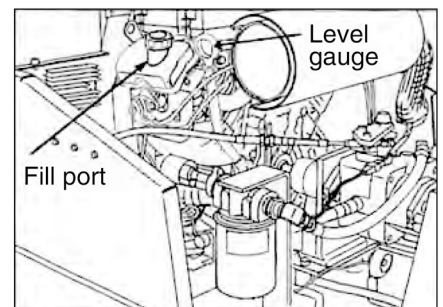

⚠ WARNING

When draining a hot oil, use care not to get burned.

⚠ CAUTION

Be sure to use engine oil recommended by SAKAI (refer to page 62).

NOTE: For a new machine, change oil filter cartridge at 50 operating hours for the initial time only.

⑬ Battery

- 1) Check the condition of the battery and replace it as necessary.
 Check the color of the hydrometer at top of the battery to confirm the condition of the battery.
 Green Satisfactory
 Black Charging is necessary
 Semitransparent ... Replacement is necessary
- 2) When the terminal is loose, tighten it sufficiently, and thinly apply vaseline or grease to prevent rusting.

⚠ CAUTION

- **The power-supply voltage of this machine is 12 V.**
- **Use only batteries recommended by SAKAI (refer to page 61).**

3 PERIODICAL MAINTENANCE

(6) Every 200 hours

⑮ Engine oil filter

➔ See the separate engine manual.

- 1) After completion of operation and while the oil is warm drain the oil with the drain plug removed.

⚠ WARNING

When draining a hot oil, use care not to get burned.

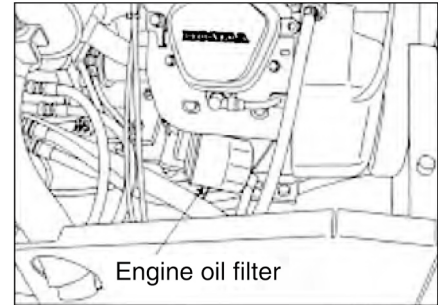

- 2) Refit the drain plug and fill the crankcase with the engine oil from the fill port.
- 3) Change the oil filter cartridge.

⚠ CAUTION

Be sure to use engine oil recommended by SAKAI (refer to page 62).

NOTE: For a new machine, change oil filter cartridge at 50 operating hours for the initial time only.

(7) Every 300 hours

⑰ Fuel strainer

➔ See the separate engine manual.
Change the fuel strainer.

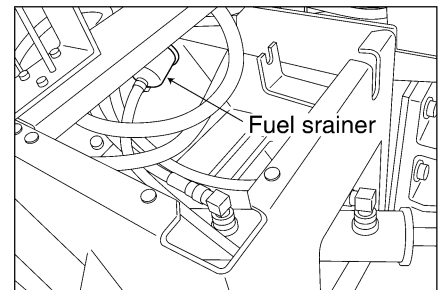

⑱ Fuel strainer

➔ See the separate engine manual.
Change the fuel strainer.

Fuel strainer

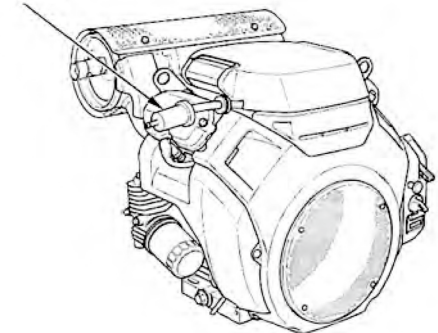

(8) Every 500 hours

③ Line filter

Remove the filter case by turning counterclockwise as viewed from the bottom, and change the element.

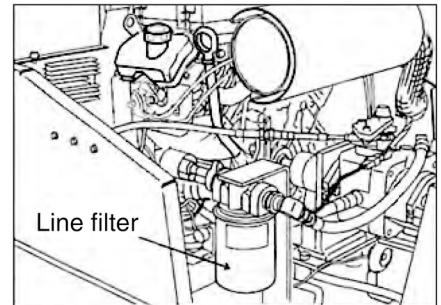

⑧ Hydraulic oil tank

- 1) Remove the drain plug, and drain oil while it is warm.
- 2) Clean inside of the tank, and fill fresh oil to the specified level.
- 3) Start and run the engine at idling for 2 to 5 minutes. When the hydraulic oil has become free from air bubbles, stop the engine and recheck the oil level.

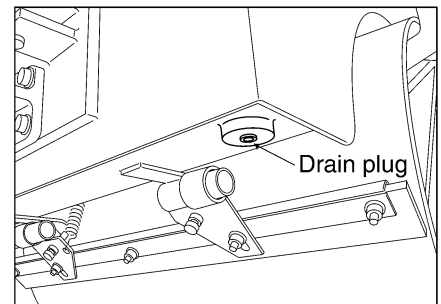

⚠ WARNING

When draining a hot oil, be careful not to get burned.

⚠ CAUTION

Be sure to use hydraulic oil recommended by SAKAI (refer to page 62).

3 PERIODICAL MAINTENANCE

⑩ Air cleaner

Check or clean the element as described below:

- 1) Pull the air cleaner cover latch to the unlocked position, and remove the cover.
- 2) Remove the wing nut from the filter element assy.
- 3) Remove the filter element assy from the air cleaner case.
- 4) Replace the filter element assy.
- 5) Reinstall the filter element assy. Be sure the packing is in place beneath the filter element assy. Tighten the wing nut securely.
- 6) Lock the air cleaner cover latch securely.

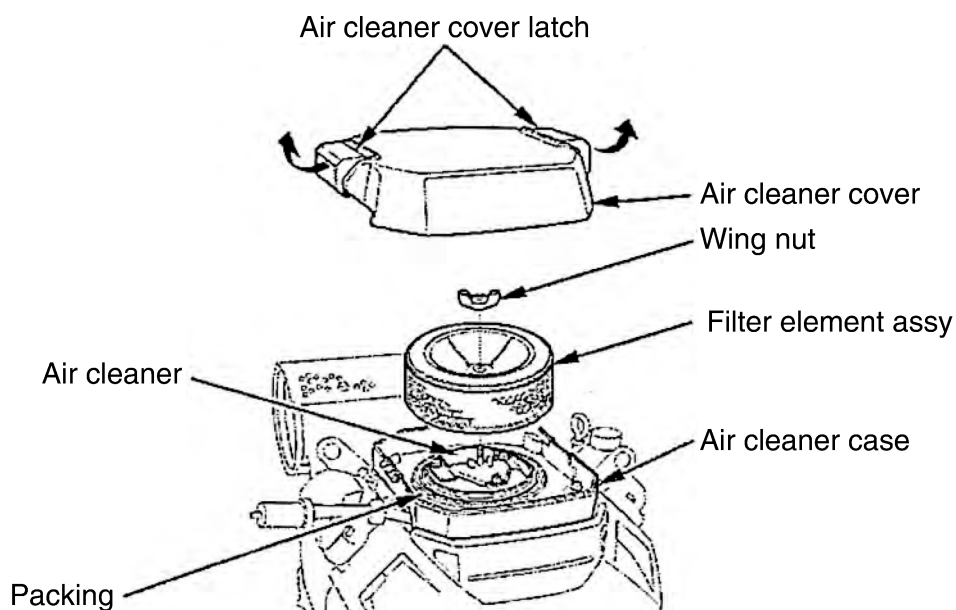

⚠ WARNING

Exercise caution not to get a speck of dust in your eye.

NOTE: Change the element once in every six cleanings.

(9) As required**① Scraper**

When the gap between the drum and blade has grown large, adjust the scraper properly. To clear muds accumulated between the drum and scraper blade, raise the blade.

⚠ WARNING

Be careful not to pinch your fingers between the drum and blade.

See page 30 for adjustment.

② Sprinkler pipe

Clean or change.

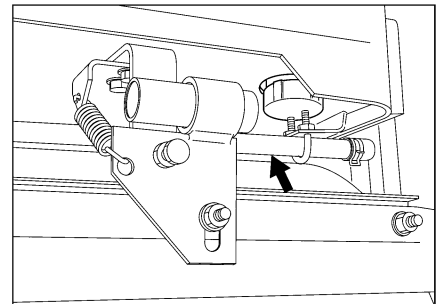
**⑫ Sprinkler tank**

Open the drain cap at the bottom of the tank and feed water through the fill port to clean the inside of the tank. When cleaning is complete, close the valve.

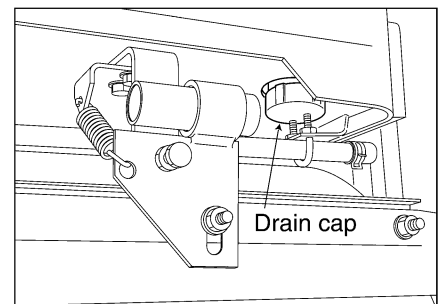

3 PERIODICAL MAINTENANCE

⑰ Air cleaner

Check or clean the element as described below:

- 1) Pull the air cleaner cover latch to the unlocked position, and remove the cover.
- 2) Remove the wing nut from the filter element assy.
- 3) Remove the filter element assy from the air cleaner case.
- 4) Inspect both filter element assy, and replace them if they are damaged.
- 5) Tap the filter element assy several times on a hard surface to remove dirt, or blow compressed air [not exceeding 207 kPa (2.1 kgf/cm², 30 psi)] through the filter element from the air cleaner case side.

Never try to brush off dirt; brushing will force dirt into the fibers. Replace the filter element assy if it is excessively dirty.

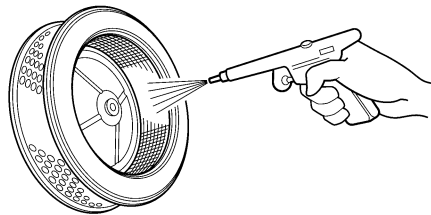

- 6) Reinstall the filter element assy. Be sure the packing is in place beneath the filter element assy. Tighten the wing nut securely.
- 7) Lock the air cleaner cover latch securely.

⚠ WARNING

Exercise caution not to get a speck of dust in your eye.

NOTE: Change the element once in every six cleanings.

⑳ Fuel tank

- 1) With the drain plug removed, remove the water and sediment from the bottom of the tank.
- 2) If sedimentation is substantial, remove the drain plug and clean the interior of the tank.
- 3) When the necessary work and refueling are complete, tighten the filler cap positively.

⚠ WARNING

- The fuel will catch fire if open flames or ignition sources are used close to it.
- Do not smoke or use a match or cigarette lighter close to it.



NOTE: When removing the water and sediment from the tank filled with the fuel, the fuel will gush out if the drain plug is screwed out completely.

3.5 Consumable Parts

Replace consumable parts such as filter elements and air cleaner elements during periodical maintenance or before reaching the wear limit. Proper replacement of consumable parts will improve the overall life of the machine, resulting in cost-effective operations.

Use genuine SAKAI parts as replacement parts.

The part numbers are subject to change due to the improvements to the parts.

When ordering parts, make sure to obtain the latest part numbers by checking with our distributorship or one of our certified service shops of the version, model name and model number of the machine in use.

Consumable Part	Part No.	Interval		Remark
		Annual replacement (year)	Replacement per operation (hours)	
Engine oil filter cartridge	4033-05003-0		200	
Fuel strainer	4033-05002-0		300	
Air cleaner element assembly	4033-05001-0		As required	
Suction filter element (hydraulic oil)	4210-68000-0		500	
Line filter cartridge (hydraulic oil)	4211-64001-0		500	
Scraper blade (front wheel)	1456-71002-0		As required	
Scraper blade (rear wheel)	1456-71002-0		As required	
Battery	4910-55000-0		As required	55B24R

3.6 Feeding Water and Lubricants

(1) General rules

- 1) Never feed water or lubricant with the strainer removed.
- 2) Use recommended lubricant and hydraulic fluid.
- 3) Do not use lubricants and hydraulic fluid of different brands.
- 4) When replacing oil, drain it completely and clean the container with flushing oil before filling new oil.

(2) Capacity

Compartment	Type of fluid	Capacity in liters (gal.)
Fuel tank	Gasoline	30 (7.9)
Engine oil pan	Engie oil	1.9 (0.5)
Hydraulic oil tank	Hydraulic oil	30 (7.9)
Sprinkler tank	Water	150 (40)

(3) Rating

Lubricant	Service classification	Ambient temp. and applicable viscosity rating			Applicable standards
		-25 – 40°C (-13 – 104°F) Cold	-15 – 40°C (5 – 104°F) Moderate	10 – 40°C (50 – 104°F) Tropical	
Engine oil	API grade SJ or later	Synthetic SAE 5W-30	SAE 10W-30	SAE 30	MIL-L-2104C
Hydraulic oil	Wear resistant	ISO-VG32 over VI 140	ISO-VG46 over VI 140	ISO-VG68 over VI 110	ISO-3448
Grease	Lithium type extreme pressure				NLGI-2
Fuel	Gasoline				JIS · K2202-2

(4) Recommended lubricants

Oil company \ Lubricant	Engine oil API SJ or later	Gear oil API GL 5	Hydraulic oil ISO-VG 46	Grease (NLGI - 2)
CHEVRON	DELO 400 LE	RPM Universal Gear Lubricants	Rando HDZ 46	Martifack EP 2
BP	BP Select Motor oil	BP Energear HYPO-U	Bartran HV 46	BP Energear LS – EP 2
CASTROL	Tecton HD	EXP Gear OILS	Castrol Hyspin AWH 46	Castrol Spheerol ELP 2
EXXON MOBIL	Mobil Super	Mobilube HD	Mobil DTE 10 Excel 46	Mobilux EP 2
SHELL	Shell Helix	Shell Spirax S2 A 90	Shell Tellus S2 V 46	Shell Alvania Grease EP 2

⚠ CAUTION

- **Fill the fluid reservoirs with the filters installed.**
- **Use recommended fuels and lubricants only.**
- **Use the hydraulic oils which specifications are as clean as ISO4406 18/13 or above.**

3.7 Electric Wiring Diagram

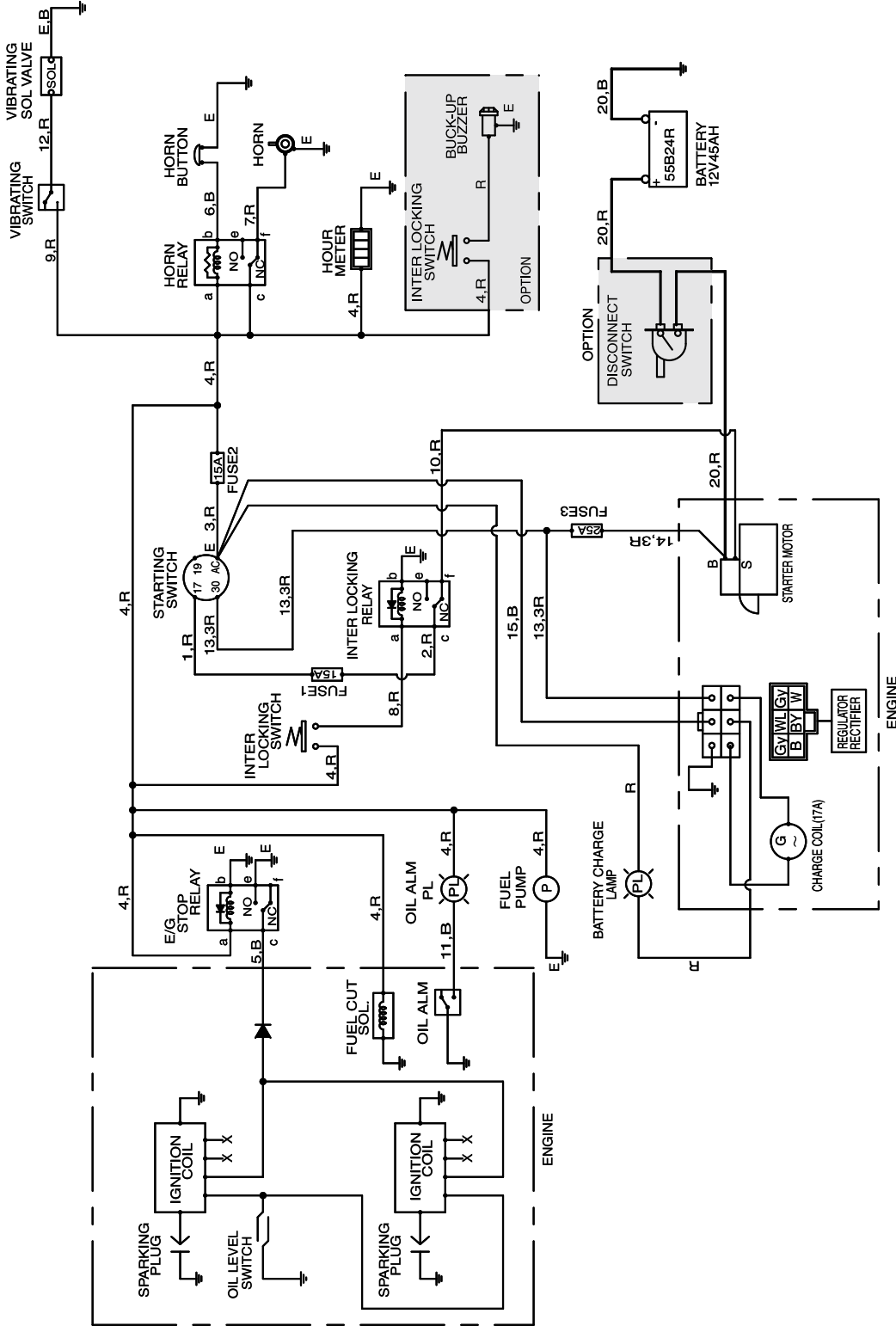

CAUTION: Size of wires not indicated by letters are AV 0.85.

Color of wire

B	Black	BrR	Brown/Red stripe	GR	Green/Red stripe	LR	Blue/Red stripe	P	Pink	RW	Red/White stripe	WR	White/Red stripe	YR	Yellow/Red stripe	LB	Blue/Black stripe
BR	Black/Red stripe	BrW	Brown/White stripe	GW	Green/White stripe	LW	Blue/White stripe	R	Red	RY	Red/Yellow stripe	Y	Yellow	YW	Yellow/White stripe	WG	White/Green stripe
BW	Black/White stripe	G	Green	GY	Green/Yellow stripe	LY	Blue/Yellow stripe	RB	Red/Black stripe	W	White	YB	Yellow/Black stripe	BY	Brown/Yellow stripe		
BY	Black/Yellow stripe	GB	Green/Black stripe	Gr	Gray	Lg	Light green	RG	Red/Green stripe	WB	White/Black stripe	YG	Yellow/Green stripe	Sb	Blue		
Br	Brown	GL	Green/Blue stripe	L	Blue	O	Orange	RL	Red/Blue stripe	WL	White/Blue stripe	YL	Yellow/Blue stripe	BG	Black/Green stripe		

OPTION

Fuse box

The fuse is housed in the fuse holder on the way of a wiring. Be sure to use fuses of correct capacity consulting the the electric wiring diagram (refer to page 64).

NOTE: When a fuse is burned, determine the cause before replacing.

Battery

- ★ When the battery is left unused for a long time or the electricity is used too much, the pole plates will be damaged, shortening its service life extremely.
- ★ When the battery will not be used for a long time, charge it sufficiently, leave it in the shade in a cool, dry place, and check its condition every month.
- ★ Keep the battery in a satisfactory condition at all times.
- ★ The battery should be in a satisfactory condition when the engine is to be started on cold days. Avoid starting the engine with the battery in a poor condition at any time.

4 SPECIFICATIONS

4 SPECIFICATIONS

(1) CR271

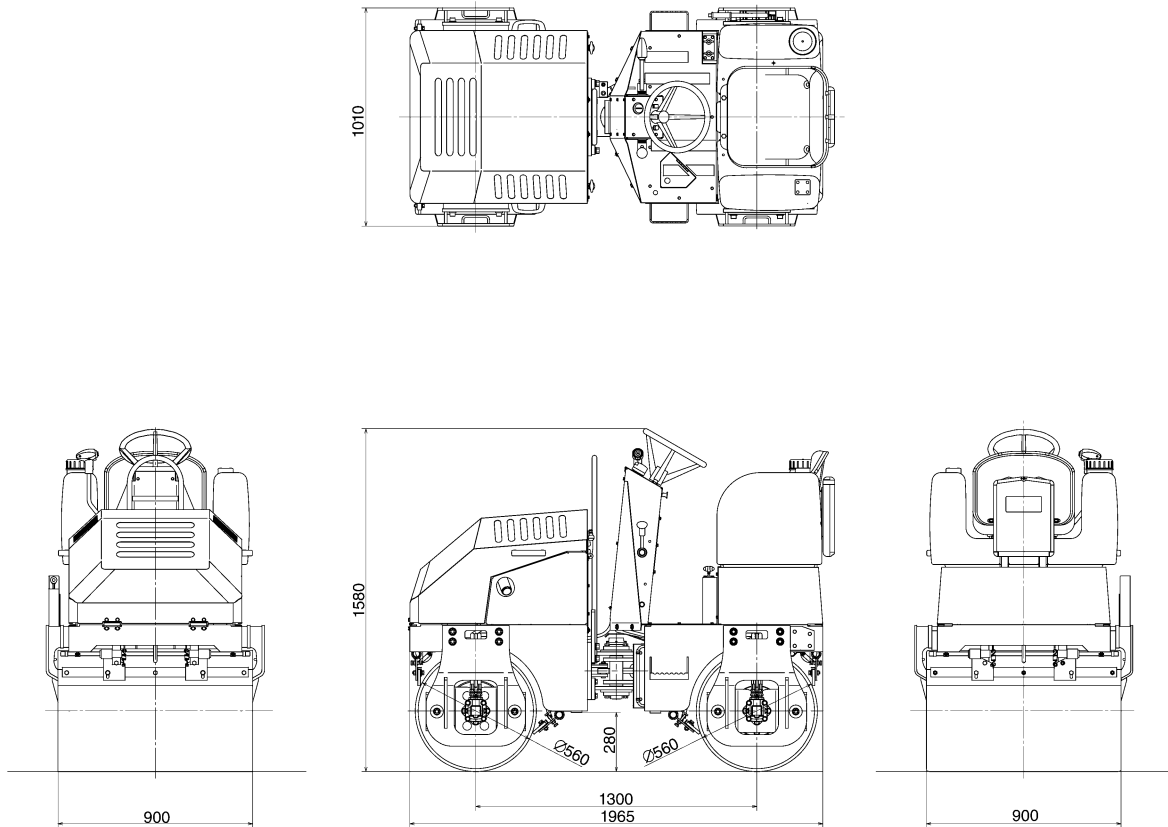

Model	CR271
Weight	
Operating weight	1,430 kg (3,155 lbs)
On front axle	660 kg (1,460 lbs)
On rear axle	770 kg (1,700 lbs)
Dimension	
Overall length	1,965 mm (77")
Overall width	1,010 mm (40")
Overall height	1,580 mm (62")
Wheelbase	1,300 mm (51")
Wheel	
Front	Roll (dia. x width) 560 x 900 mm (22" x 35")
Rear	Roll (dia. x width) 560 x 900 mm (22" x 35")
Performance	
Travel speed (forward / reverse)	0 – 7.5 km/h (0 – 4.7 mile/h)

Performance	
Vibration system	
Frequency	66.7 Hz (4,000 vpm)
Centrifugal force	13.2 kN {1,345kgf} (2,965 lbs)
Gradeability	14 degrees
Compaction width	900 mm (35")
Minimum turning radius	2.9 m (115")
Engine	
Model	HONDA "GX630" Gasoline Engine
Total displacement	0.688 L (42.0 cu.in)
Rated output	12.0 kW/3,600 min ⁻¹ (16 HP/3,600 rpm)
Max. torque	48.3 N·m/2,500 min ⁻¹ (36 ft·lb/2,500 rpm)
Tank capacity	
Fuel tank	30 L (7.9 gal)
Hydraulic oil tank	30 L (7.9 gal)
Sprinkler tank	150 L (39.6 gal)

NOTE: 1) Gradeability is the calculated value. It may vary with ground surface conditions.
 2) According to European Standards (EN500-1, ISO 6165, etc.), the weight are defined as follows.
 Operating weight: Fuel=50%, Water=50%, Operator=75kg

(2) CR271 with ROLL BAR

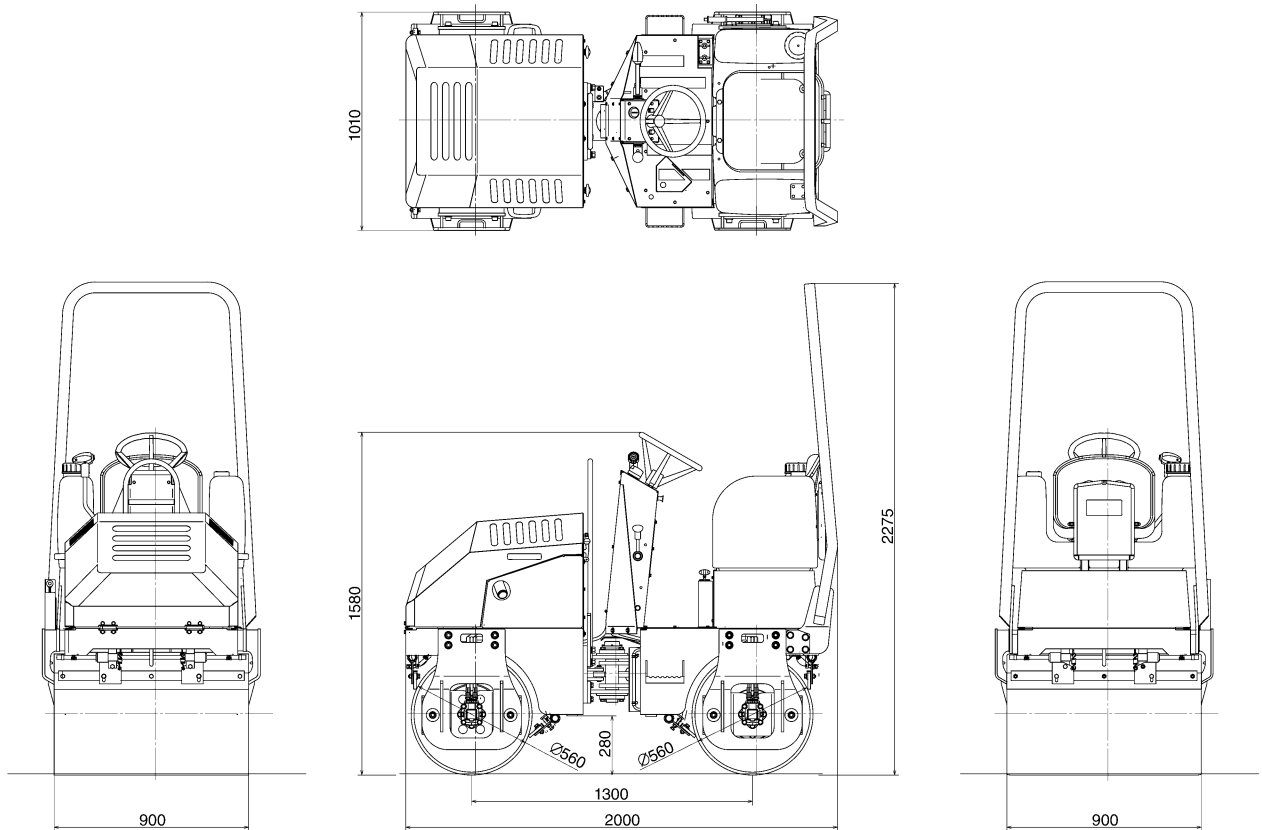

Model		CR271 with ROLL BAR		Performance	
Weight				Vibration system	
Operating weight	1,470 kg (3,245 lbs)			Frequency	66.7 Hz (4,000 vpm)
On front axle	650 kg (1,435 lbs)			Centrifugal force	13.2 kN {1,345kgf} (2,965 lbs)
On rear axle	820 kg (1,810 lbs)			Gradeability	14 degrees
Dimension				Compaction width	900 mm (35")
Overall length	2,000 mm (79")			Minimum turning radius	2.9 m (115")
Overall width	1,010 mm (40")			Engine	
Overall height (with ROLL BAR)	2,275 mm (90")			Model	HONDA "GX630"
Overall height (without ROLL BAR)	1,580 mm (62")			Gasoline Engine	
Wheelbase	1,300 mm (51")			Total displacement	0.688 L (42.0 cu.in)
Wheel				Rated output	12.0 kW/3,600 min ⁻¹ (16 HP/3,600 rpm)
Front	Roll (dia. x width)			Max. torque	48.3 N·m/2,500 min ⁻¹ (36 ft·lb/2,500 rpm)
	560 x 900 mm (22" x 35")			Tank capacity	
Rear	Roll (dia. x width)			Fuel tank	30 L (7.9 gal)
	560 x 900 mm (22" x 35")			Hydraulic oil tank	30 L (7.9 gal)
Performance				Sprinkler tank	150 L (39.6 gal)
Travel speed	0 – 7.5 km/h (0 – 4.7 mile/h)				
(forward / reverse)					

NOTE: 1) Gradeability is the calculated value. It may vary with ground surface conditions.
 2) According to European Standards (EN500-1, ISO 6165, etc.), the weight are defined as follows.
 Operating weight: Fuel=50%, Water=50%, Operator=75kg

4 SPECIFICATIONS

(3) CR271 with ROPS

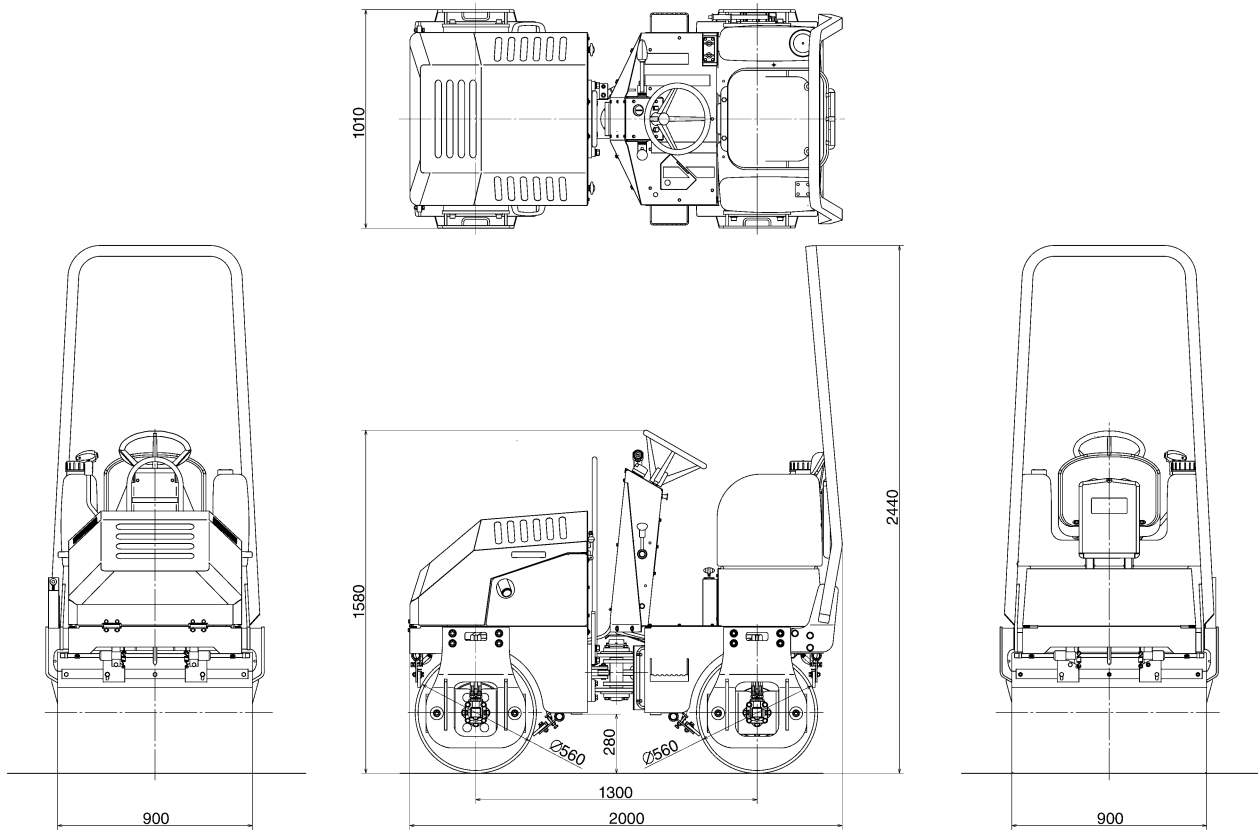

Model	CR271 with ROPS
Weight	
Operating weight	1,470 kg (3,245 lbs)
On front axle	650 kg (1,435 lbs)
On rear axle	820 kg (1,810 lbs)
Dimension	
Overall length	2,000 mm (79")
Overall width	1,010 mm (40")
Overall height (with ROPS)	2,440 mm (96")
Overall height (without ROPS)	1,580 mm (62")
Wheelbase	1,300 mm (51")
Wheel	
Front	Roll (dia. x width) 560 x 900 mm (22" x 35")
Rear	Roll (dia. x width) 560 x 900 mm (22" x 35")
Performance	
Travel speed (forward / reverse)	0 – 7.5 km/h (0 – 4.7 mile/h)

Performance	
Vibration system	
Frequency	66.7 Hz (4,000 vpm)
Centrifugal force	13.2 kN {1,345kgf} (2,965 lbs)
Gradeability	14 degrees
Compaction width	900 mm (35")
Minimum turning radius	2.9 m (115")
Engine	
Model	HONDA "GX630" Gasoline Engine
Total displacement	0.688 L (42.0 cu.in)
Rated output	12.0 kW/3,600 min ⁻¹ (16 HP/3,600 rpm)
Max. torque	48.3 N·m/2,500 min ⁻¹ (36 ft·lb/2,500 rpm)
Tank capacity	
Fuel tank	30 L (7.9 gal)
Hydraulic oil tank	30 L (7.9 gal)
Sprinkler tank	150 L (39.6 gal)

NOTE: 1) Gradeability is the calculated value. It may vary with ground surface conditions.
 2) According to European Standards (EN500-1, ISO 6165, etc.), the weight are defined as follows.
 Operating weight: Fuel=50%, Water=50%, Operator=75kg

SAKAI HEAVY INDUSTRIES, LTD.

Head Office: 1-4-8, Shibadaimon, Minato-ku,
Tokyo, Japan

Telephone: 81-3-3431-9971

Facsimile: 81-3-3436-6212

SAKAI HEAVY INDUSTRIES, LTD.