

SAKAI®

CR271

Asphalt Rollers



CR271

Vibratory Tandem Roller

All drum drive, articulated steering, compact size tandem type vibrating roller.

CR271 designed for small paving jobs, road maintenance, road widening, roadway, parking lots, bicycle paths, sports courts, small asphalt applications and rental house fleets.

Compaction Performance

- Front drum vibration frequency of 4,000 vpm (66.7 Hz) allows highly efficient compaction with optimum impact spacing without sacrificing speed.
- Chamfered drum edge for smoother mat.

Comfort and Safety

- Excellent 360-degree visual angle and drum edge visibility for added safety.
- 39" forward and rear visibility.

Easy Maintenance

- Heavy duty center joint.
- Long life Sakai patented rubber isolators for drums.
- Flip open engine hood provides easy accessibility to engine and components for daily maintenance and service.

www.sakaiamerica.com

Options shown. Contact your dealer for details.

CR271

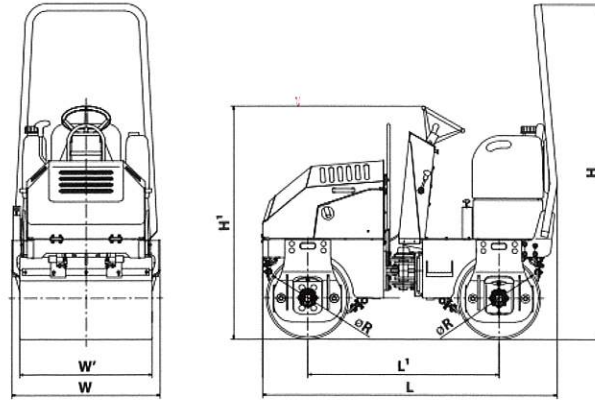

TYPE		Vibratory Tandem Roller	
MODEL		CR271	
CHASSIS MODEL		4CR2	
MASS	Operating Mass (with ROPS)	lbs(kg)	3,440 (1,560)
	Load on front axle (with operating mass)	lbs(kg)	1,435 (650)
	Load on rear axle (with operating mass)	lbs(kg)	1,810 (820)
PERFORMANCE	Centrifugal force for front drum	lbs(kN)	2,965 (13.2)
	Frequency for front drum	vpm(hz)	4,000 (66.7)
	Amplitude for front drum	in(mm)	0.014 (0.35)
	Dynamic linear pressure for front drum (operating weight with ROPS)	lb/in(N/cm)	120 (218)
	Static linear pressure for rear drum (operating weight with ROPS)	lb/in(N/cm)	50 (90)
	Number of speeds		1
	Speed range	mph(km/h)	0-4.7 (0-7.5)
	Theoretical Gradeability	%(°)	25 (14)
	Theoretical outside turning radius	in(m)	115 (2.9)
	DIMENSIONS	Overall length L ²	in(mm)
Overall width W ²		in(mm)	40 (1,010)
Overall height (without ROPS) H		in(mm)	62 (1,580)
Overall height (with ROPS) H		in(mm)	96 (2,440)
Wheelbase L ¹		in(mm)	51 (1,300)
Compaction width W ¹		in(mm)	54 (1,380)
Drum width / Drum diameter		in(mm)	35 / 22 (900 / 560)
Shell thickness		in(mm)	0.5 (13.5)
Ground clearance		in(mm)	11 (280)
Curb clearance		in(mm)	13 (325)
Side clearance		in(mm)	2 (55)
ENGINE		Make	
	Model		GX630
	EPA emission standard		EPA Phase 3, China Stage I
	Type		Gasoline, air cooled, 4 cycle, 2 cylinder, V-type
	Displacement	cu. in(L)	42 (0.688)
	Rated output	HP(kW)/min ⁻¹	16 (12) / 3,600
	Electric system battery	V(V/Ah×Qty)	12 (12 / 36×1)
	Electric system alternator	V/A	12 / 17
DRIVE SYSTEM	Transmission type		Hydrostatic
	Drive wheel		Both drums
VIBRATION SYSTEM	Power transmission type		Hydraulic
	Vibrator type		Single eccentric shaft
BRAKE SYSTEM	Service brake		Dynamic braking through hydrostatic drive system / F-N-R lever
	Secondary brake (Emergency brake)		N/A
	Parking brake		Mechanical, disc type / parking brake lever
STEERING SYSTEM	Power Transmission Type		Hydraulic (Articulated)
	Steering / Oscillating angle	±(°)	30 / 0
FLUID CAPACITY	Fuel tank	gal(L)	7.9 (30)
	Hydraulic oil tank	gal(L)	7.9 (30)
	Water sprinkler tank	gal(L)	39.6 (150)

- Operating mass : Fuel=50%,Water=50%,Operator=165lbs.
- Specifications are subject to change without notice.
- Above specified numbers could be deviated within ±5%.
- All Imperial units are for reference. Inside of () are SI units.
- Using low quality fuel may cause engine failure.
- Engine meets EPA standards.

Standard Equipment

- Scrapers for both directions · Horn · Comfort seat · Water sprinkler system (gravity)
- 1 point lifting

Optional Equipment

- Strobe light · Folding ROPS
- The photos may contain optional equipment and/or attachment.