

CR271

SHOP MANUAL

SAKAI®

3498-65634-1

Introduction

This manual provides important information to familiarize you with safe operating and maintenance procedures for your SAKAI roller. Even though you may be familiar with similar equipment you must read and understand this manual before operating or servicing this unit.

Safety is everyone's business and it is one of your primary concerns. Knowing the guidelines presented in this manual will help provide for your safety, for the safety of those around you and for the proper operation and maintenance of the machine. Improper operation is dangerous and can result in injury or death.

Sakai Heavy Industries cannot foresee all possible circumstances or varying conditions to which the operator, serviceman or machine may be exposed to that might lead to a potential hazard. Therefore, the warnings and cautions listed in this manual and those placed on the machine are not intended to be all inclusive and liability for personal injury or damage to equipment or property cannot be assumed.

All information, specifications and illustrations in this publication are based on the product information available at the time that the publication was written. The contents may change without prior notice due to modifications of the model.

CONTENTS

1. SAFETY

1. GENERAL SAFETY

1-1. Understanding the Safety Symbols and Words	1-001
1-2. General	1-001
1-3. Qualifications of Operators and Maintenance Personnel	1-002
1-4. Safety Practices and Policies.....	1-002
1-5. Pre Start Inspection.....	1-003
1-6. Safety Instructions	1-003
1-7. Starting.....	1-004
1-8. Operating.....	1-004
1-9. Stopping	1-004
1-10. Maintenance.....	1-005
1-11. Transporting the Machine.....	1-007

2. SPECIFICATIONS

1. SPECIFICATION DATA

1-1. CR271	2-001
------------------	-------

2. TABLE OF STANDARD VALUES

2-1. Engine.....	2-003
2-2. Propulsion.....	2-003
2-3. Hydraulic Systems	2-003
2-4. Steering.....	2-004
2-5. Capacities.....	2-004

3. FUEL AND LUBRICANTS SPECIFICATION

3-1. Rating	2-005
3-2. Recommended Lubricants	2-005

4. TIGHTENING TORQUE CHART.....	2-006
---------------------------------	-------

3. ENGINE AND CONTROLS

1. ENGINE

1-1. Engine Mount	3-001
-------------------------	-------

2. CONTROL SYSTEM

2-1. Throttle Control.....	3-002
2-2. Forward-reverse Control	3-003

3. PUMP MOUNT

3-1. Pump Mount	3-004
3-1-1. Installation of pump	3-005

4. HYDRAULIC SYSTEMS

1. SYSTEM CIRCUIT DIAGRAM

1-1. Graphic Symbols for Hydraulic Circuits	4-001
1-2. Hydraulic Circuit Diagram	4-003

2. PROPULSION HYDRAULIC SYSTEM

2-1. Propulsion Hydraulic Piping	4-004
2-1-1. Propulsion hydraulic piping (1)	4-004
2-1-2. Propulsion hydraulic piping (2)	4-005
2-2. Hydraulic Component Specifications	4-006
2-2-1. Hydraulic pump assembly (propulsion + vibrator + steering)	4-006
2-2-2. Propulsion hydraulic motor	4-008
2-2-3. Valve block	4-009
2-2-4. Valve	4-010

3. VIBRATOR HYDRAULIC SYSTEM

3-1. Vibrator Hydraulic Piping	4-011
3-2. Hydraulic Component Specification	4-012
3-2-1. Vibrator hydraulic motor	4-012

4. STEERING SYSTEM

4-1. Steering Hydraulic Piping	4-013
4-2. Hydraulic Component Specifications	4-014
4-2-1. Orbitrol	4-014
4-3. Frame (Center Pin)	4-015

5. SYSTEM CIRCUIT DIAGRAM (FROM 20552)

5-1. Hydraulic Circuit Diagram	4-016
--------------------------------	-------

6. PROPULSION HYDRAULIC SYSTEM (FROM 20552)

6-1. Propulsion Hydraulic Piping (2)	4-017
6-2. Hydraulic Component Specifications	4-019
6-2-1. Relief valve	4-019

7. VIBRATOR HYDRAULIC SYSTEM (FROM 20552)

7-1. Vibrator Hydraulic Piping	4-020
--------------------------------	-------

①

5. ELECTRICAL SYSTEM

1. PRECAUTIONS FOR WORK

- 1-1. Wire Numbers, Wire Sizes, Wire Colors and Connectors Shown in
Electrical Circuit Diagrams, Wiring Harness Layout and Wiring Harnesses 5-001

2. SYSTEM CIRCUIT DIAGRAM

- 2-1. Electrical Circuit Diagram 5-003

3. ELECTRICAL COMPONENTS

- 3-1. Electrical component Layout 5-004

4. WIRING HARNESES

- 4-1. Harness (1) 5-005

- 4-2. Harness (2) 5-007

- 4-2-1. Harness (to 20293, from 20318 to 20329) 5-007

- 4-2-2. Harness (from 20294 to 20317, 20330) 5-009

- 4-2-3. Harness (from 20331) 5-011

6. DRUMS

1. PRECAUTIONS FOR DISASSEMBLY AND REASSEMBLY 6-001

2. REMOVAL AND INSTALLATION OF DRUMS

- 2-1. Removal of Drums 6-003

- 2-1-1. Front drum 6-003

- 2-1-2. Rear drum 6-006

- 2-2. Installation of Drums 6-008

3. DRUM ASSEMBLY

- 3-1. Front Drum 6-009

- 3-2. Rear Drum 6-010

4. DISASSEMBLY AND REASSEMBLY OF DRUMS

- 4-1. Disassembly of Drums 6-011

- 4-1-1. Front drum 6-011

- 4-1-2. Rear drum 6-018

- 4-2. Reassembly of Drums 6-024

- 4-2-1. Front drum 6-024

- 4-2-2. Rear drum 6-034

7. PARKING BRAKE

1. PARKING BRAKE

- 1-1. Brake 7-001

8. WATER SPRAY SYSTEM

1. WATER SPRAY SYSTEM

1-1. Water spray	8-001
------------------	-------

9. INSPECTION AND ADJUSTMENT

1. INSPECTION AND ADJUSTMENT

1-1. Safety Precautions for Inspection and Adjustment	9-001
1-2. Preparation for Inspection and Adjustment	9-001
1-3. Precautions for Inspection and Adjustment	9-001
1-4. Warm-up	9-001
1-5. Inspection and Adjustment of Engine Related Items	9-001

2. MEASUREMENT AND INSPECTION OF PROPULSION CIRCUIT PRESSURE

2-1. Measurement	9-002
2-2. Adjustment	9-003

3. MEASUREMENT AND INSPECTION OF PROPULSION CHARGE CIRCUIT PRESSURE

3-1. Measurement	9-004
3-2. Adjustment	9-005

4. MEASUREMENT AND ADJUSTMENT OF STEERING CIRCUIT PRESSURE

4-1. Measurement	9-006
4-2. Adjustment	9-007

5. MEASUREMENT OF HYDRAULIC PUMP CASE PRESSURE

5-1. Measurement	9-008
------------------	-------

6. MEASUREMENT OF PROPULSION MOTOR CASE PRESSURE

6-1. Measurement	9-009
------------------	-------

7. ADJUSTMENT OF THROTTLE LEVER LINKAGE

7-1. Adjustment	9-010
-----------------	-------

8. ADJUSTMENT OF F-R LEVER LINKAGE

8-1. Adjustment	9-012
-----------------	-------

10. TROUBLESHOOTING

1. TROUBLESHOOTING

1-1. Safety Precautions for Troubleshooting	10-001
1-2. Important Information for Troubleshooting	10-001
1-3. Before Starting	10-002
1-4. Wire Number and Color Code	10-002

2. ELECTRICAL SYSTEM TROUBLESHOOTING

2-1. When Performing Electrical System Fault Diagnosis	10-003
2-1-1. Precautions to take during electrical circuit fault diagnosis	10-003
2-1-2. Inspection procedures using a tester	10-004
2-1-3. Inspection of electrical system	10-009
2-2. Engine	10-012
2-2-1. Engine will not start (Starter motor does not run)	10-012
2-2-2. Engine will not start (But starter motor runs)	10-014
2-2-3. No charging	10-016
2-2-4. Starter motor runs even when F-R lever is not at "N" applied	10-016
2-3. Propulsion	10-018
2-3-1. Hour meter is abnormal	10-018
2-3-2. Horn does not sound	10-018
2-4. Vibration	10-020
2-4-1. No vibration occurs	10-020

3. HYDRAULIC SYSTEM TROUBLESHOOTING

3-1. When Performing Hydraulic System Troubleshooting	10-021
3-2. Propulsion System	10-022
3-2-1. Machine moves neither forward nor backward	10-022
3-2-2. Machine moves in one direction only (forward or backward)	10-023
3-2-3. Slow machine speed or small drive force	10-023
3-2-4. Machine does not stop completely with F-R lever in "N"	10-024
3-2-5. Propulsion system is overheating	10-024
3-2-6. Abnormal noise from propulsion system	10-024
3-3. Steering System	10-025
3-3-1. Steering wheel is hard to turn	10-025
3-3-2. Steering response is slow	10-025
3-3-3. Steering wheel backlash or play is large	10-026
3-3-4. Steering system is overheating	10-026
3-3-5. Abnormal noise from steering system	10-026

SAFETY

1. GENERAL SAFETY

1-1. Understanding the Safety Symbols and Words

The words DANGER, WARNING, and CAUTION are used with the safety-alert symbol. DANGER identifies the most serious hazard. When the symbols DANGER, WARNING and CAUTION are displayed, become alert. Your safety or those around you may be involved. NOTICE is used to provide important information that is not hazard related.

 **DANGER:** Indicates an imminently hazardous situation or condition which if not avoided can result in serious personal injury or death.

 **WARNING:** Indicates a potentially hazardous situation or condition which if not avoided can result in serious personal injury or death.

 **CAUTION:** Indicates a potentially hazardous situation or condition which if not avoided may result in moderate personal injury or damage to the machine or personal property.

(NOTICE): Indicates important information about operation or maintenance of the machine that may cause damage, breakdown, or shortened service life of the machine if you fail to observe or important point to maintain of quality in maintenance works.

★ : Indicates standard value to judge whether measured value is good or not.



Items that indicate the weight of a part or equipment and require attention in wire selection and operating posture for slinging operation.



In the assembly operation, tightening torque in locations that require particular attention.

1-2. General

- Operators and maintenance personnel must be alert to recognize and avoid potential hazards. They should also have comprehensive training, the required skills and necessary tools to perform the job safely.
- The machine was built in accordance to the latest safety standards and recognized safety rules. Nevertheless, misuse of the machine may result in risk to life and limb of the user or nearby personnel and may cause damage to the machine or other property.
- The machine must only be used for its intended purpose as described in the Operator's Manual. It must be operated by safety-conscious persons who are fully aware of the risks involved when operating the machine. Any malfunctions especially those affecting the safety of the machine must be corrected immediately.

- The machine is designed specifically for the compaction of asphalt or soil road construction materials. Use of the machine for other purposes such as towing other equipment is considered contrary to the designated use. The manufacturer cannot be responsible or held liable for any damage resulting from such use. The risk for such use lies entirely with the user.
- Operating the machine within the limits of its designated use also involves compliance with the inspection and maintenance requirements contained in the Operation and Maintenance Manual.

1-3. Qualifications of Operators and Maintenance Personnel

- Work on the machine must be performed by qualified personnel only. Individual responsibilities of personnel regarding operation, maintenance, repair of the machine must be clearly stated.
- Define the operator's responsibilities; the operator should have authority to refuse instructions that are contrary to safety.
- Do not allow persons being trained to operate or perform maintenance on the machine without constant supervision by an experienced person.
- Work on the electrical system of the machine must be done only by an experienced person or under the guidance of a skilled electrician and according to electrical engineering rules and regulations.
- Work on the frame, brakes, hydraulic and steering systems must be performed by skilled personnel with special knowledge and training for such work.

1-4. Safety Practices and Policies

- Keep the manuals in the container provided on the machine. Manuals must always be available at the site where the machine is being used.
- The operator or user of the machine must be aware of all applicable or legal and mandatory regulations relevant to accident prevention and environmental protection. These regulations may also deal with handling of hazardous substances, the required proper personal safety and protective equipment and traffic or jobsite regulations.
- Machine operating instructions should also be supplemented with detailed instructions pertaining to the specific jobsite or work location.
- Always be sure the persons working on the machine have read the operating instructions and all safety precautions before beginning work. Reading safety instructions after work has already begun is too late.
- Wear close fitting garments and always tie back and secure long hair, also avoid wearing jewelry such as rings. Injury can result from loose clothing, hair or jewelry being caught up in the machinery or rotating parts.
- Use protective equipment as required by the circumstances or by law.



- Observe all safety instructions and warnings attached to the machine.
- Make sure all safety instructions and warnings on the machine are complete and perfectly legible.
- Stop the machine immediately in the event of any malfunction. Report any malfunction immediately to the supervisor or other person of authority.
- Never perform service or maintenance on the machine unless the drums or tires are adequately blocked, articulation lock bar and pin is in the locked position and the parking brake is applied.
- Never make any modifications to the machine which might affect safety without the manufacturer's approval.
- Always perform the recommended routine inspections and adjustments according to the prescribed intervals.

1-5. Pre Start Inspection

- Inspect your machine daily. Ensure that the routine maintenance and lubrication are properly performed. Repair or replace any malfunctioning, broken or missing parts before using the machine. Refer to the maintenance schedule in the Operator's Manual.
- Check that all instructions and safety stickers are in place and readable.
- Never fill the fuel tank with the engine running or while near an open flame or while smoking.
- Always clean up any spilled fuel.
- Check for any warning tags placed on the machine, do not operate the machine until all repairs have been made and warning tags have been removed by authorized personnel.
- Check the seat belt for wear or damage; inspect the belt hardware and fabric. Replace if hardware is damaged or the belt is frayed or nicked or stitching is loose. Check that mounting hardware is tight.
- Clean the steps and operating platform of dirt and foreign matter to reduce danger of slipping.
- Know how to shut-down or stop the machine immediately in case of emergency.
- Know the capabilities and limitations of the machine such as speed, gradeability, steering and braking.
- Be aware of the dimensions of the machine such as height, weight especially for transporting.

1-6. Safety Instructions

- Take all necessary precautions to ensure that the machine is used only when in a safe and reliable condition.
- Avoid any operational mode that might compromise safety.
- Operate the machine only if all protective and safety devices are in place and fully functional.
- Always use the hand rails and steps to get on and off your machine maintaining 3-point contact (using both hands).

1-7. Starting

- Start the machine only from the driver's seat and always wear the seat belt.
- Watch that the warning lights and indicators during start-up and shutdown are working in accordance with operating instructions.
- Watch that no one is in danger before starting and when moving the machine.
- Check that braking, steering, signals and lights are fully functional before starting work or traveling with the machine.

1-8. Operating

- Always make sure that there are no obstructions or persons in your line of travel before starting the compactor in motion.
- Never climb on and off the machine while it is in motion.
- Always remain seated with the seat belt fastened when traveling, compacting or loading or unloading the machine.
- Use caution and be very observant when operating in close quarters and congested areas.
- Obey all traffic regulations when working on public roads and make sure machine is compatible with these regulations.
- Never carry passengers.
- Know and use the hand signals for particular jobs and who has the responsibility for signaling.
- Do not work close to edges or in the vicinity of overhanging banks or on grades that could cause the compactor to slide or roll over. Avoid any areas that may be a risk to machine stability.
- Avoid side hill travel. Always operate up and down the slope. Always keep the propulsion (travel control) lever in low speed range when climbing or descending hills or steep grades.
- Make sure there is sufficient clearance when crossing underpasses, bridges and tunnels or when passing under overhead power lines.
- Never allow anyone to stand in the articulation area of the machine when the engine is running.
- Always look in all directions before reversing the direction of travel.
- Always switch on the lighting system (if equipped) during poor visibility conditions and after dark.
- Do not attempt to control the compactor travel speed with the throttle control. Maintain engine speed at the full operating RPM.
- Do not run the engine in a closed building for an extended period of time. Exhaust fumes can kill.

1-9. Stopping

- Always park the machine in a safe area on solid and level ground. If this is not possible, always park at a right angle to the slope and block the drums or tires.
- Do not leave the operator's platform with the engine running. Always move the travel lever to neutral position and apply the parking brake then turn the starter switch to OFF.
- Lock all lockable compartments.
- Park behind a safe barrier, use proper flags, and warning devices, especially when parking in areas of heavy traffic.

1-10. Maintenance

- In any performing any work concerning the operation, adjustment or modification of the machine or it's safety devices or any work related to maintenance, inspection or repair, always follow the start-up and shut-down procedures in the Operator's Manual and the Maintenance Manual.
- Ensure that the maintenance area is safe and secure.
- If the machine is shut down for maintenance or repair work it must be secured against inadvertent starting by removing the starter key and attaching a warning sign to the starter switch.
- The machine must be parked on stable and level ground with the drums or tires blocked to prevent inadvertent movement.
- Immediately after the engine has stopped, the exhaust system, engine, radiator coolant, engine oil, hydraulic fluid and other lubricants and components will be very hot. Fluids can be under pressure, removing the radiator cap or draining oil or changing filters can cause serious burns. Wait until the machine has cooled down.
- Use care when attaching and securing lifting tackle to individual parts and large assemblies being removed or repositioned for repair purposes to avoid the risk of accident. Use lifting devices that are in perfect condition and of sufficient lifting capacity. Never stand under suspended loads.
- Always use the proper tools and workshop equipment in good condition when performing maintenance or repairs on the machine.
- Always use specially designed safety ladders and working platforms when working above floor level. Never use machine parts as a climbing aid.
- Keep all steps, handles, handrails, platforms and ladders free from mud, dirt, grease, ice or snow.
- Clean the machine, especially threaded connections of any traces of oil or fuel before carrying out any maintenance or repairs. Never use aggressive detergents. Use lint free cleaning rags.
- Examine all fuel, lubricant and hydraulic fluid lines and connectors for leaks, loose connections chafe marks or damage after cleaning.
- Repair or replace defective parts immediately.
- Whenever possible, avoid servicing or maintenance when the engine is running unless the drums or tires are adequately blocked, the articulation lock bar is in the locked position and the parking brake is applied.
- Never fill the fuel tank with the engine running, while near an open flame or while smoking. Always clean up any spilled fuel.
- Ensure safe operation, optimum performance of the machine and its warranty by using only genuine SAKAI replacement parts.

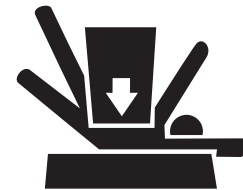

SAFETY

- Use only the specified fluids and lubricants. Substitute only products known to be equivalent from reputable manufacturers.
- Disconnect the battery cables when working on the electrical system or when welding on the compactor.
- Be sure the battery area is well ventilated (clear of fumes) should it be necessary to connect a jumper cable or battery charger. Fumes can ignite from a spark and may explode.
- Be sure battery charger is OFF when making connections if charging is required.
- Use only original fuses with the specified rating. Switch off the machine immediately if trouble occurs in the electrical system.
- Work on the electrical system may only be carried out by a qualified electrician or by a specially trained person according to electrical engineering principles.
- Inspect the electrical equipment of the machine at regular intervals. Defects such as loose connections or burnt or scorched wires must be repaired or replaced immediately.
- Do not weld, flame cut or perform grinding on the machine unless expressly authorized, as there may be a risk of fire or explosion. Disconnect the battery when welding on the machine.
- Clean the machine and its surrounding from dust or other flammable substances and make sure the area is adequately ventilated before beginning welding, flame cutting or grinding operations.
- Inspect hydraulic hoses at regular intervals and immediately replace if they show signs of chafing, cracking, brittleness, deformation, blistering, fitting separation, leakage, corrosion or other damage which may affect their function or strength.
- Do not work on hydraulic system while the engine is running and the system is under pressure. The hydraulic system remains pressurized even after the engine has stopped.
- Do not disconnect hydraulic hoses or fittings until the pressure has been properly relieved.
- Wait until the systems and fluid have cooled down before disconnecting.
- Never use your hands to check for leaks when inspecting a hydraulic system. Use a piece of cardboard and always wear gloves and safety glasses.



- Get immediate medical attention if fluid has been injected under your skin. Fluid penetration from a pin hole leak can cause severe injury or death.
- Ensure that hydraulic lines and hoses are routed and fitted properly. Ensure that no connections are interchanged. All fittings, lengths and specifications of hoses must comply with the technical requirements.
- Observe all product safety regulations when handling fuel, oils, grease, engine coolant and other chemical substances. Be careful especially when these items are hot as there is a risk of burning or scalding.
- Operate internal combustion engines and fuel operated heating systems only in adequately ventilated premises. Before starting the engine in an enclosed area, make sure there is sufficient ventilation.



1-11. Transporting the Machine

- Use only suitable and approved trailers and haul vehicles and lifting equipment of sufficient capacity.
- Entrust to experienced personnel the fastening and lifting of loads and instructing of crane operators.
- Only experienced persons familiar with the operation of the machine may load and unload the machine.
- Use ramps or a loading dock when loading or unloading the machine. Ramps must be the proper strength, low angle and the proper height and width.
- Block the drums or tires (front and rear) of the hauling vehicle when loading and unloading the compactor. Ensure that the haul vehicle is on level ground and approach the loading ramps squarely to make sure that the compactor does not slide off the edge of the ramp.
- Keep the deck clear of mud, oil, ice or snow or other materials that can make the deck slippery.
- Position the compactor on the trailer or transport vehicle centered from side to side, and apply the brake. Shut off the engine and lock all lockable compartments.
- Block the drums or tires and lock the articulation lock bar. Chain the machine down properly using the appropriate tackle.
- Know the overall height of the compactor and hauling vehicle. Observe height and weight regulations and be sure you can pass safely at overhead obstructions.
- Obey all traffic regulations and be sure that the proper clearance flags, lights and warning signs including “Slow Moving Vehicle” emblem are displayed when traveling on public roads.
- Know the approximate stopping distance at any given speed.
- Drive Safely. Never turn corners at excessive speeds.

SPECIFICATIONS

1. SPECIFICATION DATA

1-1. CR271

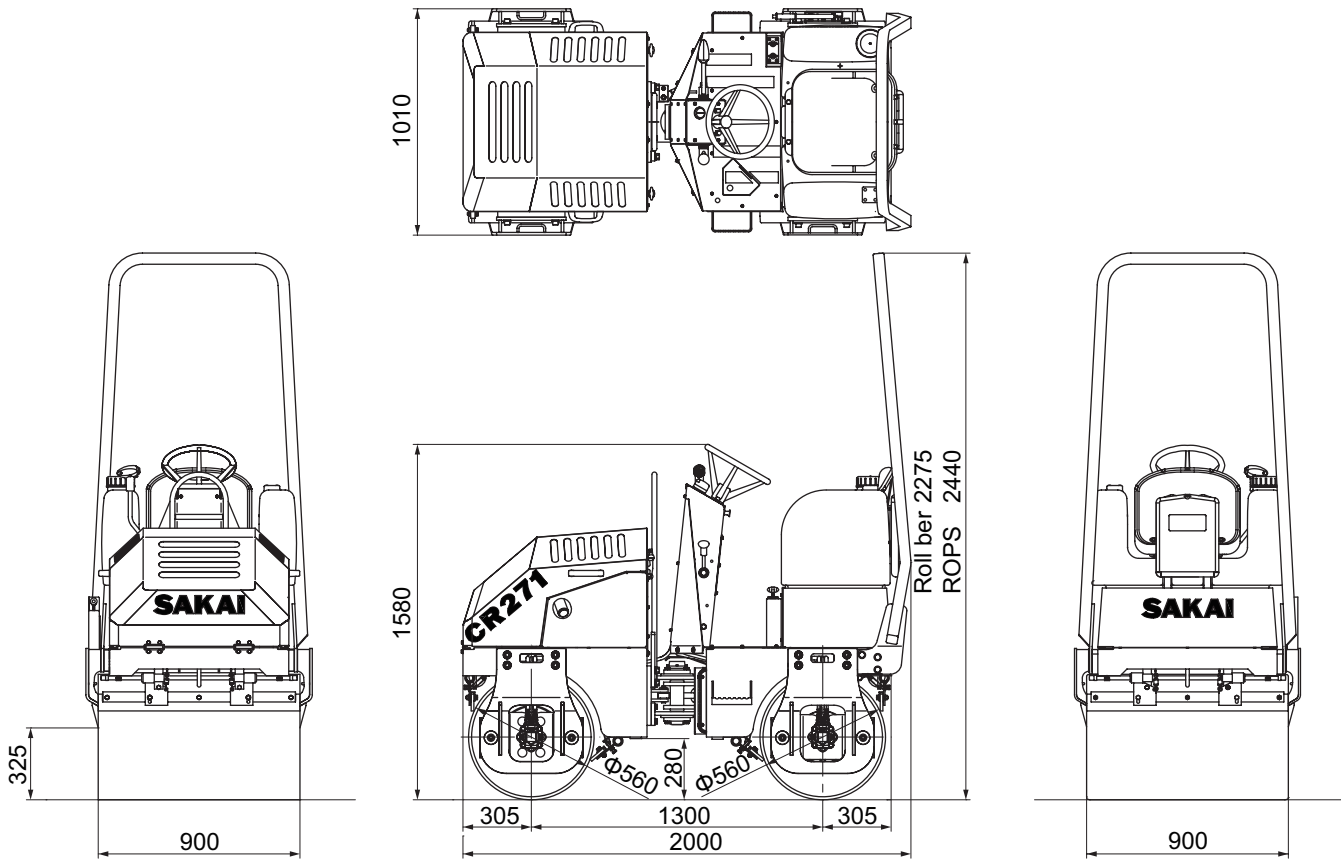

0563-99006-0-10453-0

Model		CR271		
Weight	Operating weight	1,480 kg	(3,265 lbs.)	
	Front axle	650 kg	(1,435 lbs.)	
	Rear axle	830 kg	(1,830 lbs.)	
Dimensions	Overall length	2,000 mm	(79 in.)	
	Overall width	1,010 mm	(40 in.)	
	Overall height	Steering wheel	1,580 mm	(62 in.)
		Roll bar	2,275 mm	(90 in.)
		ROPS	2,440 mm	(96 in.)
	Wheelbase	1,300 mm	(51 in.)	
	Compaction width	900 mm	(35.5 in.)	
	Minimum height above ground	280 mm	(11 in.)	
Curb clearance	325 mm	(13 in.)		
Speeds	Forward and reverse	0 to 7.5 km/h	(0 to 4.6 mile/h)	
Vibration performance	Frequency	66.7 Hz		
	Centrifugal force	13.2 kN	(2,975 lbs.)	
	Amplitude	0.35 mm	(0.014 in.)	
Minimum turning radius (outer)		2.8 m	(110 in.)	
Gradability *1		25 %	(14 °)	

*1: The gradability is the calculated value. It may vary based on the ground surface conditions.

Engine	Name		HONDA GX630R Gasoline Engine (EPA Phase3) (China Stage I)	
	Model		Air-cooled, 4-cycle, 2-cylinder, 90° V-type	
	Bore x Stroke		78 mm x 72 mm (3.071 in. x 2.835 in.)	
	Displacement		0.688 L (42 cu.in.)	
	Performance	Rated speed		3,600 min ⁻¹ (3,600 rpm)
		Rated output (SAE J1349 JUN95)		12 kW (16.1 HP) at 3,600 min ⁻¹
		Max. torque (SAE J1349 JUN95)		48.3 N·m (35.6 lbf·ft) at 2,500 min ⁻¹
		Fuel consumption (SAE J1349 JUN95)		375 g/kWh (0.616 lb/HPH) at rated speed
	Governor		Mechanical	
	Lubrication system		Full Pressure	
	Oil filter		Automotive Spin-On Style	
	Air cleaner		Dual element type	
	Cooling system		Forced air type	
	Electrical system	Alternator	12 V 17 A	
		Battery	12 V 36 Ah x 1 pcs. (12 V)	
Dry weight		44.4 kg (97.9 lbs.)		
Power line	Transmission	Type	Hydrostatic transmission	
	Reverser		Switching the direction of flow delivered from the variable pump	
Vibrating system	Transmission		Hydrostatic transmission	
	Vibrator		Eccentric shaft type	
Braking device	Service brake		Hydrostatic type	
	Parking brake		Mechanical, disc type	
Steering system	Steering control type		Hydraulic type (Articulated type)	
	Steering control angle		± 30°	
Drum	Use	Front drum	Vibrate and drive x 1	
		Rear drum	Drive x 1	
	Dimension	Front drum (width x diameter)	900 mm x 560 mm (35.5 in. x 22.0 in.)	
		Rear drum (width x diameter)	900 mm x 560 mm (35.5 in. x 22.0 in.)	
	Suspension system	Front drum	Rubber damper type	
Rear drum		Rubber damper type		
Watre spray system		Gravity		
Others	Instruments		1 set	

2. TABLE OF STANDARD VALUES

2-1. Engine

Item	Standard value		Remarks
Engine model	HONDA GX630R Gasoline Engine (EPA Phase3) (China Stage I)		
Rated output	12/3,600 kW/min ⁻¹	(16.1/3,600 HP/rpm)	
Max. rpm under no load	3,850 ± 150 min ⁻¹		
Min. rpm under no load	1,400 ± 150 min ⁻¹		
Cylinder head tightening torque	39 N·m	(29 lbf-ft)	
Intake manifold tightening torque	12 N·m	(9 lbf-ft)	
Exhaust manifold tightening torque	27 N·m	(20 lbf-ft)	
Fan belt tension	-		
Valve clearance (intake)	0.08 ± 0.02 mm	(0.003 ± 0.0008 in.)	
Valve clearance (exhaust)	0.10 ± 0.02 mm	(0.004 ± 0.0008 in.)	

2-2. Propulsion

Item	Standard value		Remarks
Travel speed (Forward and reverse)	0 to 7.5 km/h	(0 to 4.6 mile/h)	

2-3. Hydraulic Systems

Item		Standard value		Remarks	
Propulsion	High pressure relief valve setting		17.2 MPa	(2.49 psi)	
	Cut off valve setting		-		
	Charge relief valve setting		0.5 MPa	(0.07 psi)	
	Case pressure	Pump	0.1 MPa	(0.01 psi)	
		Front motor	5.0 MPa	(0.73 psi)	
		Rear motor	5.0 MPa	(0.73 psi)	
	Brake release pressure	Front motor	-		
		Rear motor	-		
		Rear axle	-		
	Drainage	Front motor	3.6 L/min	(0.95 gal/min)	
Rear motor		3.6 L/min	(0.95 gal/min)		
Vibration	High pressure relief valve setting		14.5 MPa	(2.10 psi)	
	Cut off valve setting		-		
	Charge relief valve setting		-		
	Case pressure	Pump	-		
		Motor	-		
	Drainage	Motor	2.4 L/min	(0.63 gal/min)	
Steering oil pressure		8.5 MPa	(1.23 psi)	(orbitroll relief pressure + charge relief pressure)	

2-4. Steering

Item	Standard value	Remarks
Play in steering wheel	5 to 10 mm (0.2 to 0.4 in.)	Steering wheel circumference
	5 mm (0.02 in.) or less	Steering column shaft direction

2-5. Capacities

Item	Standard value	Remarks
Engine oil pan	1.9 L (0.5 gal.)	Engine oil
Fuel tank	30 L (7.9 gal.)	Gasoline
Hydraulic oil tank	30 L (7.9 gal.)	Hydraulic oil
Water spray tank	150 L (40 gal.)	Water

3. FUEL AND LUBRICANTS SPECIFICATION

3-1. Rating

Lubricant	Service classification	Ambient temp. and applicable viscosity rating			Applicable Standards
		-30 to 0°C Cold	-20 to 40°C Moderate	10 to 40°C Tropical	
Engine oil	API grade SF or SG	SAE5W-30	SAE10W-30	SAE30	MIL-L-2104B
Gear oil	API grade GL4	SAE80W-90	SAE90	SAE140	MIL-L-2105
Hydraulic oil	Wear resistant	ISO-VG32 over VI 140	ISO-VG46 over VI 140	ISO-VG68 over VI 110	ISO-3448
Grease	Lithium type extreme pressure				NLGI-2
Fuel	Gasoline				JIS•K2202-2

3-2. Recommended Lubricants

Lubricant Oil company	Engine oil API CH-4	Gear oil API GL 4	Hydraulic oil VG 46	Grease (NLGI-II)
CALTEX	PRM DELO 300 oil	Universal Thuban 90	Rando Oil HD 46	Martifack EP 2
BP	BP Vanellus C3-30	BP Gear Oil EP 90	BP Energol HLP 46	BP Energrease LS-EP 2
ESSO	Esso Lube D3-30	Esso Gear Oil GP 90	Nuto H 46	Beacon EP 2
MOBIL	Mobil Delvac 1330	Mobil Pegasus Gear oil 90	Nuto Oil 25	Beacon EP 25
SHELL	Shell Rotella CT Oil 30	Shell Spirax 90 EP	Shell Tellus Oil 46	Shell Alvania EP Grease 2
CASTROL	Castrol CRD 30	Castrol Hypoy 90	Hyspin AWS 46	Spherrol ELP 2

4. TIGHTENING TORQUE CHART

N·m	(lbf·ft)
-----	----------

	Nominal Dia.	Pitch	Strength Classification							
			6.8		8.8		10.9		12.9	
Metric coarse screw	5	0.8	4.9	(3.6)	5.9	(4.4)	7.8	(5.8)	7.8	(5.8)
	6	1.0	7.8	(5.8)	9.8	(7.2)	13	(9.6)	13	(9.6)
	8	1.25	17	(13)	23	(17)	31	(23)	31	(23)
	10	1.5	39	(29)	49	(36)	59	(44)	59	(44)
	12	1.75	69	(51)	78	(58)	108	(80)	108	(80)
	14	2.0	98	(72)	127	(94)	167	(123)	167	(123)
	16	2.0	157	(116)	196	(145)	265	(195)	265	(195)
	18	2.5	196	(145)	245	(181)	343	(253)	343	(253)
	20	2.5	294	(217)	392	(289)	539	(398)	539	(398)
	22	2.5	441	(325)	539	(398)	686	(506)	686	(506)
	24	3.0	539	(398)	637	(470)	883	(651)	883	(651)
	27	3.0	785	(579)	981	(724)	1324	(977)	1324	(977)
	30	3.5	1079	(796)	1324	(977)	1765	(1302)	1765	(1302)
Metric fine screw	10	1.25	39	(29)	49	(36)	69	(51)	69	(51)
	12	1.25	69	(51)	88	(65)	118	(87)	118	(87)
	14	1.5	108	(80)	137	(101)	186	(137)	186	(137)
	16	1.5	167	(123)	206	(152)	284	(209)	284	(209)
	18	1.5	245	(181)	294	(217)	392	(289)	392	(289)
	20	1.5	343	(253)	441	(325)	588	(434)	588	(434)
	22	1.5	490	(361)	588	(434)	785	(579)	785	(579)
	24	2.0	588	(434)	735	(542)	981	(724)	981	(724)
	27	2.0	834	(615)	1030	(760)	1422	(1049)	1422	(1049)
	30	2.0	1177	(868)	1422	(1049)	1961	(1446)	1961	(1446)

ENGINE AND CONTROLS

1. ENGINE

1-1. Engine Mount

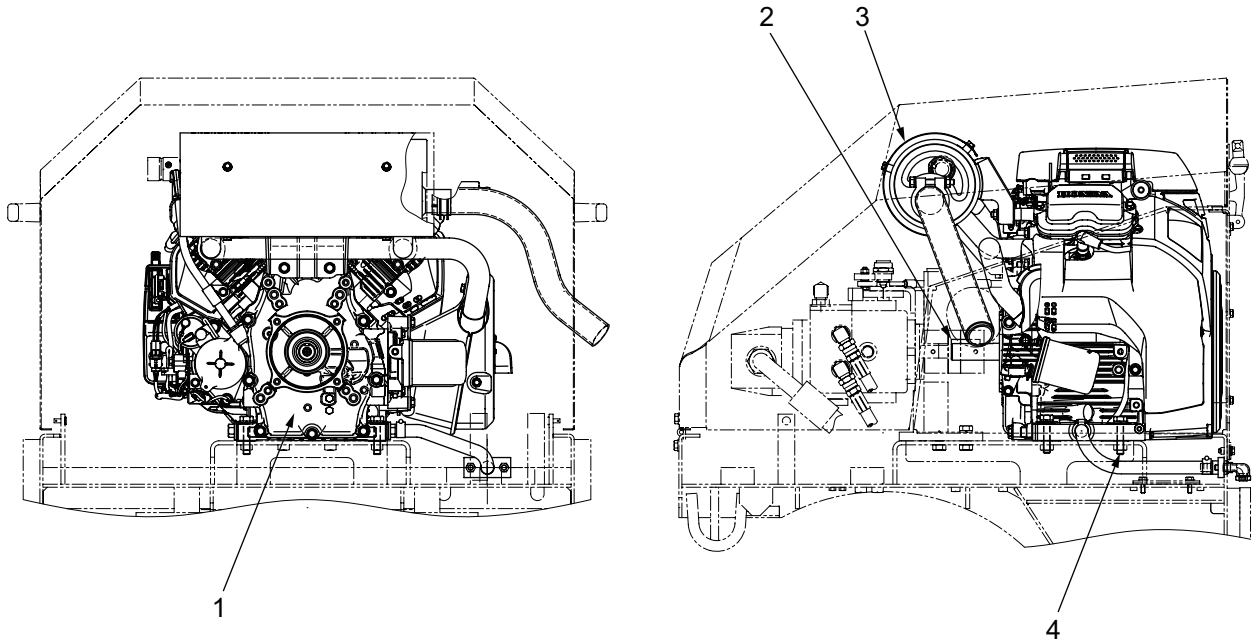

0563-01802-0-10281-B

- (1) Engine
- (2) Key
- (3) Muffler
- (4) Bolt : M10×50



- (4) Bolt M10×50 : 49 N·m (36 lbf·ft)

2. CONTROL SYSTEMS

2-1. Throttle Control

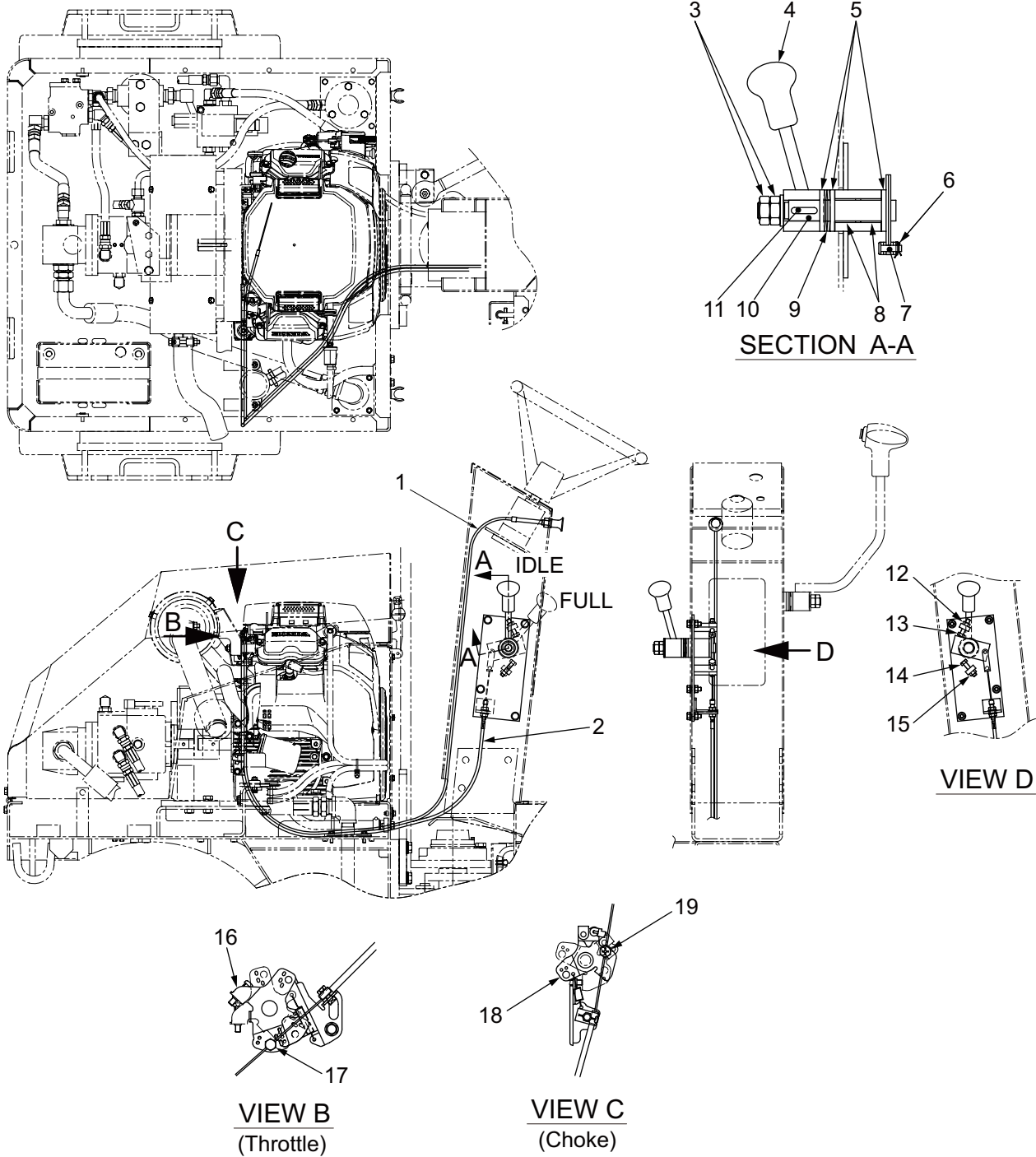

- | | | |
|------------------------------------|----------------------------------------|--------------------------|
| (1) Choke cable | (8) Bush (Apply grease) | (15) Stopper bolt (FULL) |
| (2) Control cable (Throttle Cable) | (9) Coned disc spring | (16) Throttle lever |
| (3) Nut | (10) Throttle lever pin (Apply grease) | (17) Holder |
| (4) Throttle lever | (11) Key | (18) Choke lever |
| (5) Washer | (12) Lock nut | (19) Joint |
| (6) Split pin | (13) Stopper bolt (IDLE) | |
| (7) Pin | (14) Lock nut | |

0563-12804-0 -10466-A

2-2. Forward-reverse Control

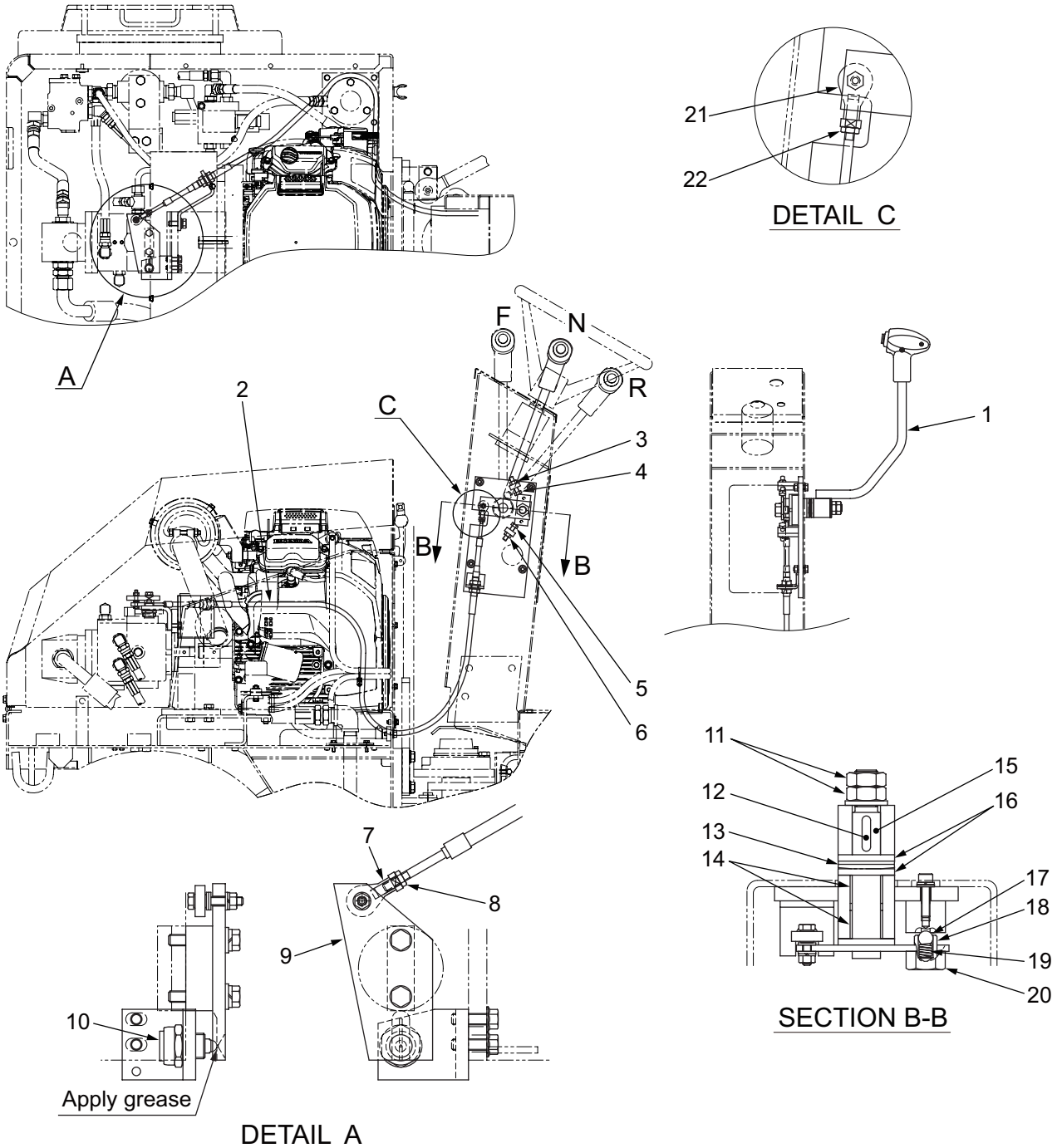

- | | | |
|-------------------------------|--------------------------|---------------------------|
| (1) F-R lever | (9) Plate | (17) Steel ball |
| (2) Control cable (F-R cable) | (10) Safety switch | (18) Set screw |
| (3) Lock nut | (11) Nut | (19) Spring (Fill grease) |
| (4) Stopper bolt (Forward) | (12) Key | (20) Nut |
| (5) Stopper bolt (Reverse) | (13) Coned disc spring | (21) Rod end |
| (6) Lock nut | (14) Bush (Apply grease) | (22) Nut |
| (7) Rod end | (15) Pin | |
| (8) Nut | (16) Washer | |

0563-12804-0 -10466-A

3. PUMP MOUNT

3-1. Pump Mount

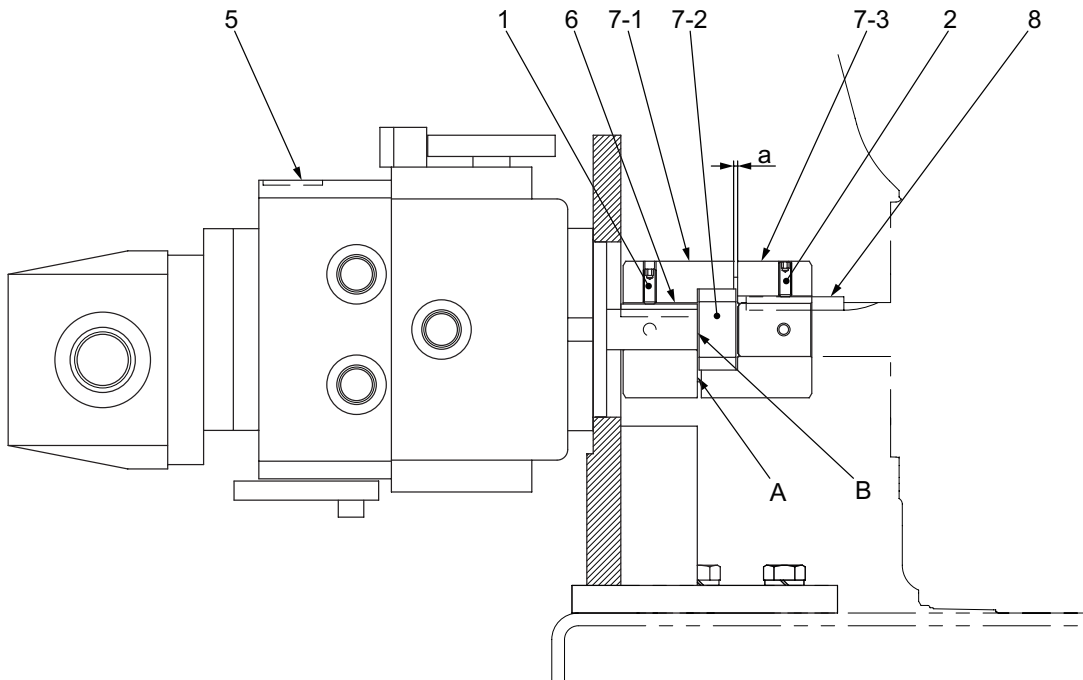
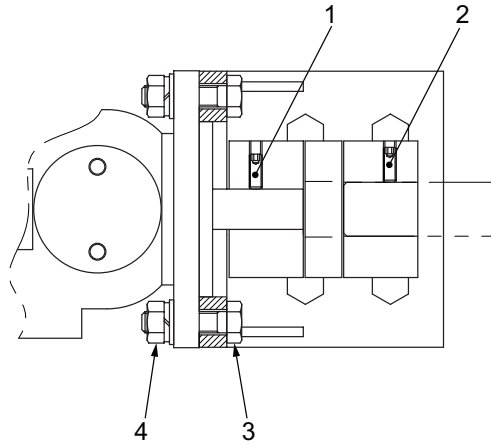

CR271-03001

- | | | |
|---------------|--------------|---------|
| (1) Set screw | (6) Key | (8) Key |
| (2) Set screw | (7) Coupling | |
| (3) Bolt | (7-1) Hub | |
| (4) Nut | (7-2) Insert | |
| (5) Pump | (7-3) Hub | |



(4) Nut : 49 N·m (36 lbf·ft)

3-1-1. Installation of pump

- When the pump has been removed from the engine for repair or replacement, reinstall it in accordance with the following procedure.

- ① Install key (6).
- ② Install hub (7-1) to pump shaft.
 - Shaft end "B" is flush with hub (7-1) surface "A".
- ③ Tighten set screws (1).
- ④ Install insert (7-2).
- ⑤ Secure pump to bracket with bolts (3), washers and nuts (4).
- Measure gap at dimension "a" between pump side hub (7-1) and engine side hub (7-3).

★ **Standard dimension a : $1.9 \pm 0.7\text{mm}$ (0.07 ± 0.03 in.)**

- If measurement result deviates from standard dimension range, loosen pump side set screw (1) in hub (7-1) and adjust the gap.

After completed adjustment, tighten set screw (1) securely.

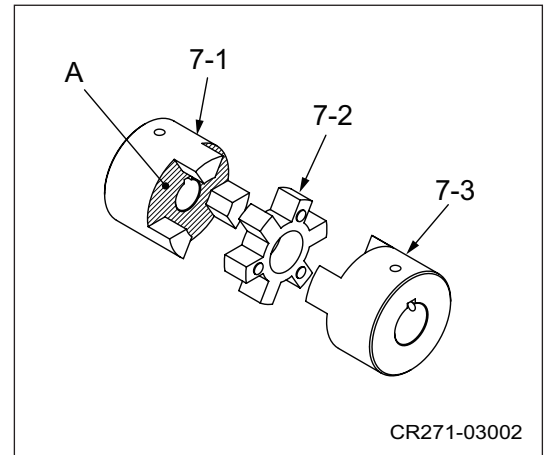

HYDRAULIC SYSTEMS

1. SYSTEM CIRCUIT DIAGRAM

1-1. Graphic Symbols for Hydraulic Circuits







Basic Symbols

DESCRIPTION	SYMBOL
Lines:	
Main working	
Pilot control	
Drain or bleed	
Lines, joining	
Not connected	
Component outline	
Arrow indicates direction of flow.	
Line with fixed restriction (orifice).	
Test port, pressure measurement.	
Temperature measurement gauge	
Pressure measurement gauge	
Reservoir (vented)	
Filter or strainer	
Heat exchanger, lines indicate flow of coolant.	
Quick disconnect: Connected with mechanically opened checks. Disconnected.	
Sloping arrow through a symbol at 45° indicates that a component can be adjusted or varied.	



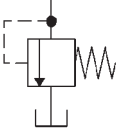

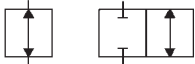
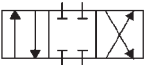

Pump, Motors and Cylinders

DESCRIPTION	SYMBOL
Hydraulic pumps:	
Fixed displacement	
Unidirectional	
Bidirectional	
Variable displacement	
Unidirectional	
Bidirectional	
Variable displacement pressure compensated Unidirectional	
Hydraulic Motor:	
Unidirectional	
Bidirectional	
Double acting hydraulic cylinder	
Differential cylinder	
Electric motor	

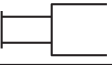
Valves

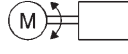
DESCRIPTION	SYMBOL
Check valve	
Manual shut off (On-Off)	
Pressure relief	
Flow control, adjustable	
Valve symbols: The basic valve symbol one or more squares with lines representing flow paths and flow conditions between ports.	
Multiple squares indicate a valve with as many distinct positions there are squares providing various flow path options for the fluid. The multiple square moves to represent how flow paths change when the valving element is shifted within the component.	
Valves with infinite positioning between certain limits are symbolized with lines parallel to the squares.	

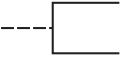
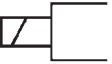
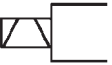
Methods of Operation

DESCRIPTION	SYMBOL
Spring	
Manual	
Pressure compensated	
Reversing motor	
Pilot pressure: Internal supply	
Remote supply	
Solenoid: Single winding	
Two windings operating in opposite directions.	
Pilot directional valve is actuated by the solenoid.	

1-2. Hydraulic Circuit Diagram

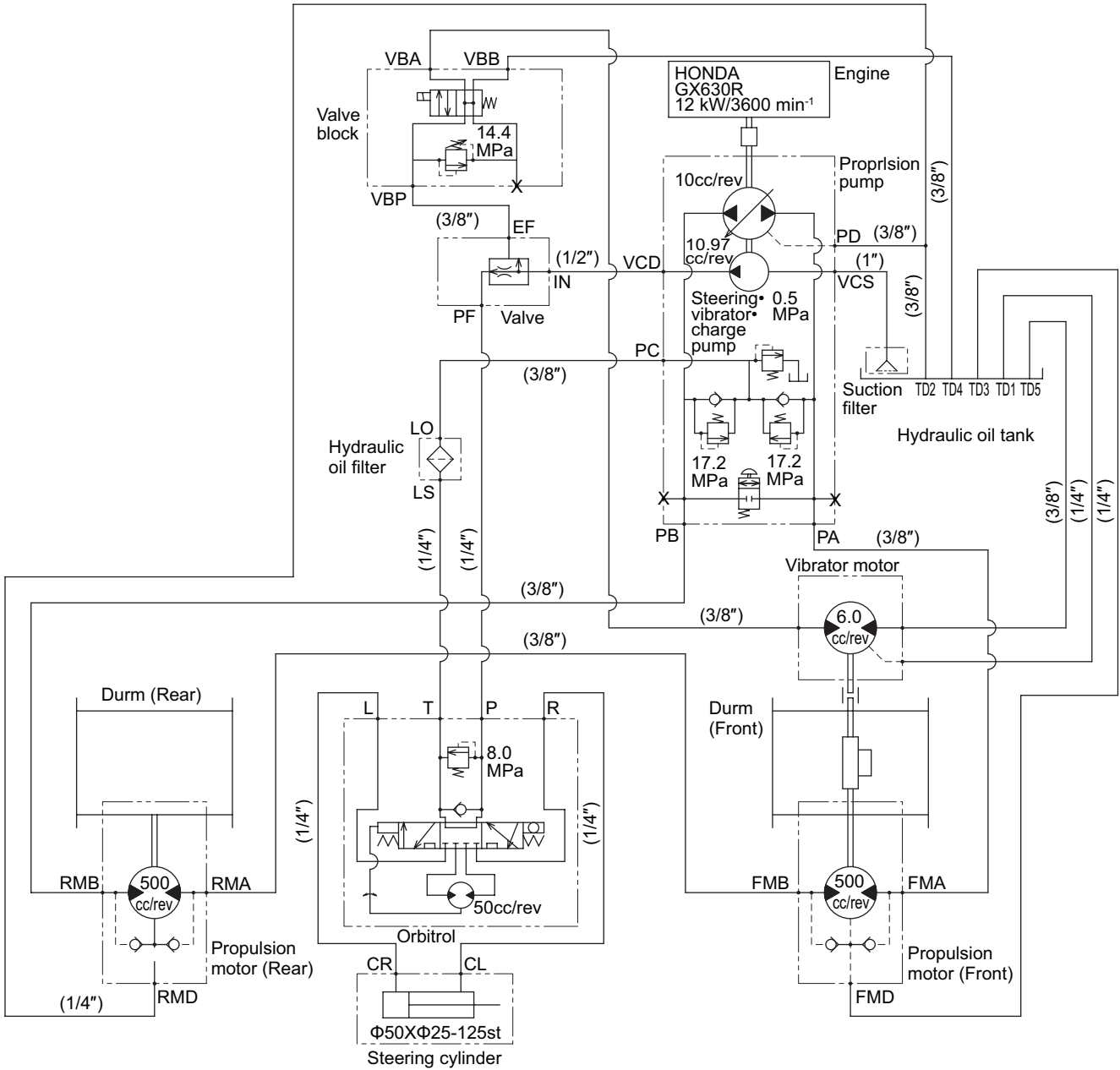

2. PROPULSION HYDRAULIC SYSTEM

2-1. Propulsion Hydraulic Piping

2-1-1. Propulsion hydraulic piping (1)

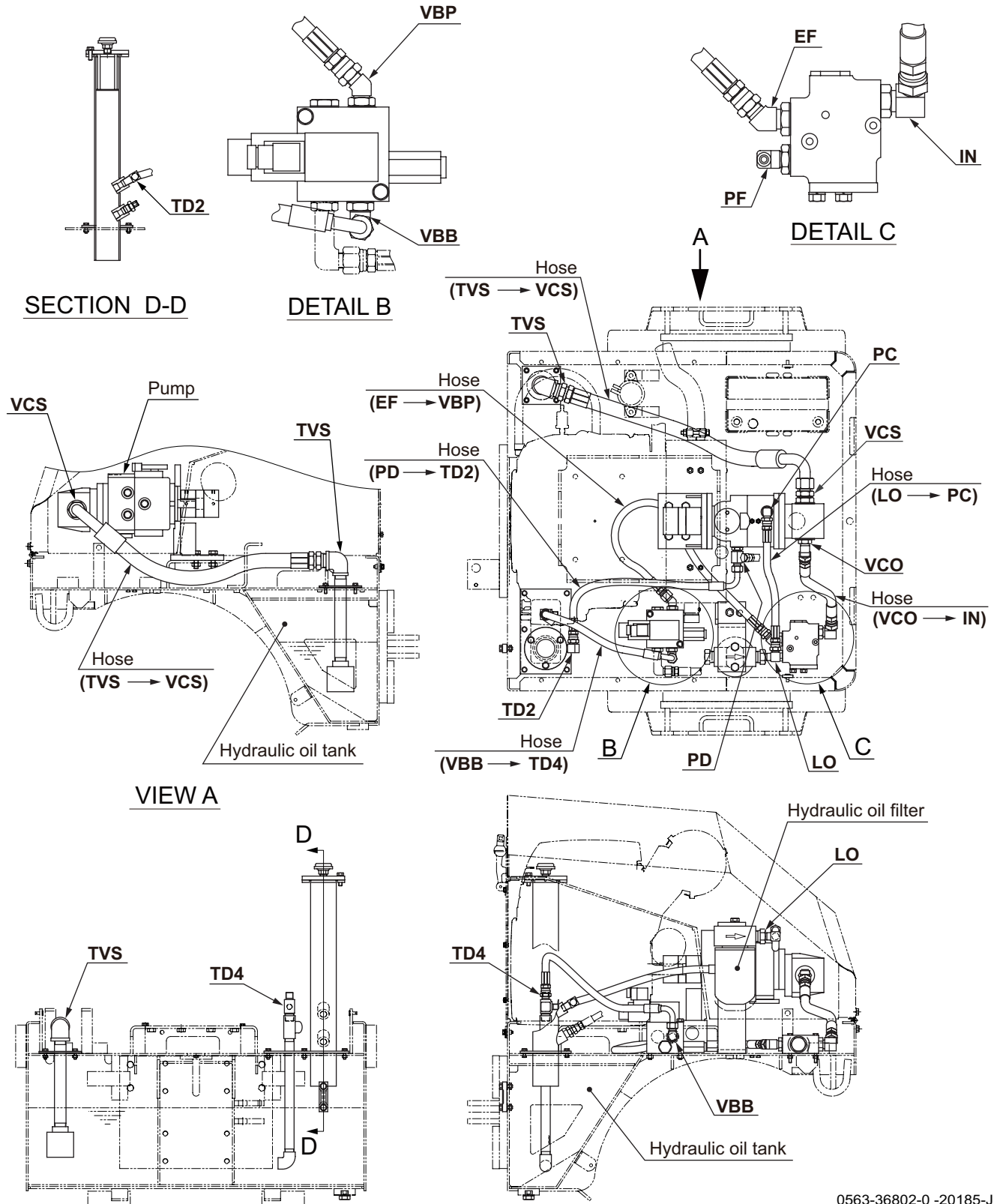

0563-36802-0 -20185-J

- The letters and figures (such as TVS and VCS) show each port and the arrow (→) symbols show the hose connection and the direction of the flow of the oil.

2-1-2. Propulsion hydraulic piping (2)

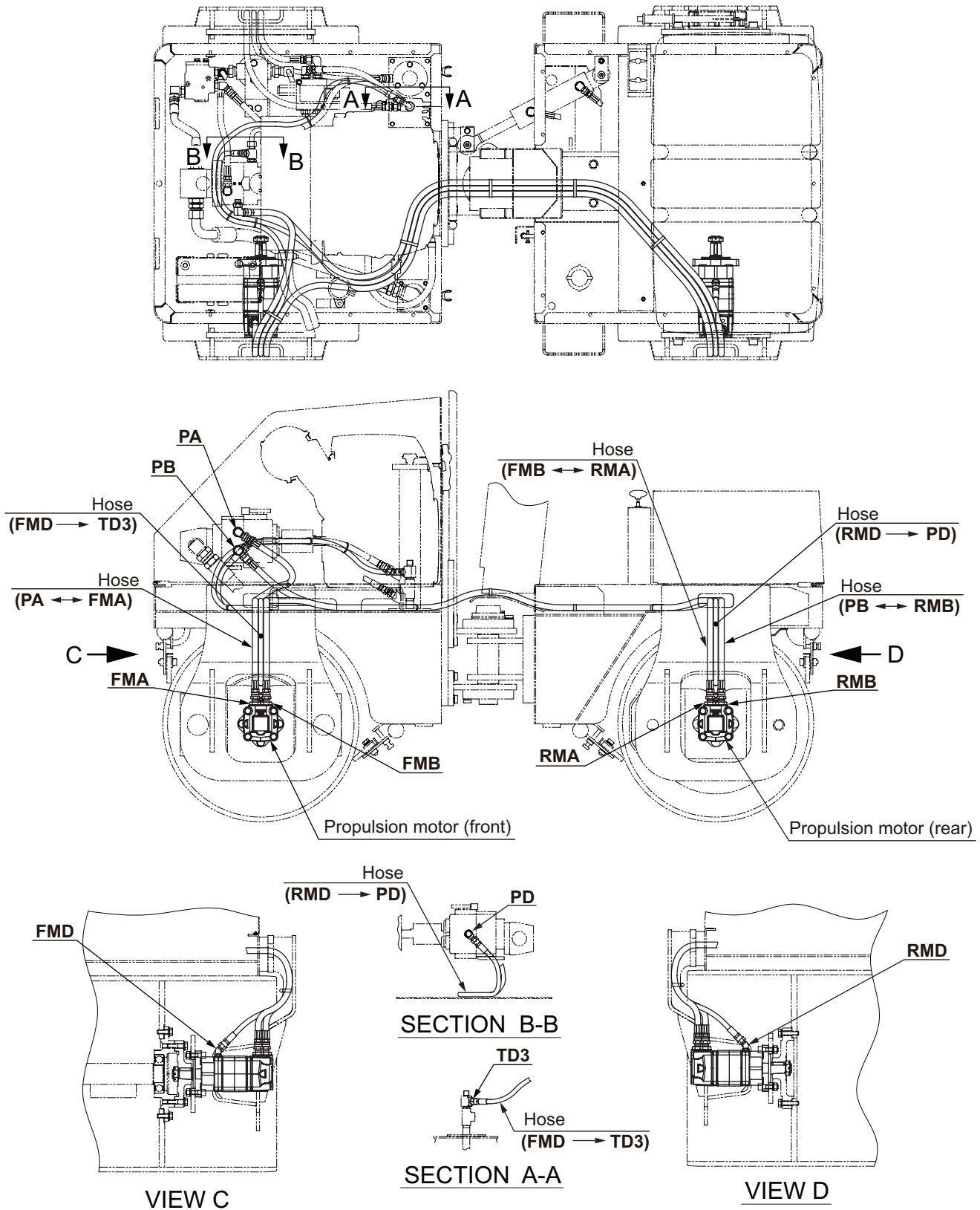

0563-36803-0-10462-0

• The letters and figures (such as FMD and TD3) show each port and the arrow (↔ ; →) symbols show the hose connection and the direction of the flow of the oil.

2-2. Hydraulic Component Specifications

2-2-1. Hydraulic pump assembly (propulsion + vibrator + steering)

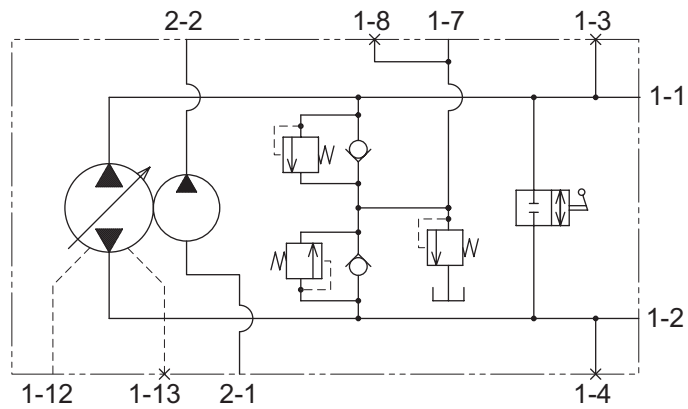
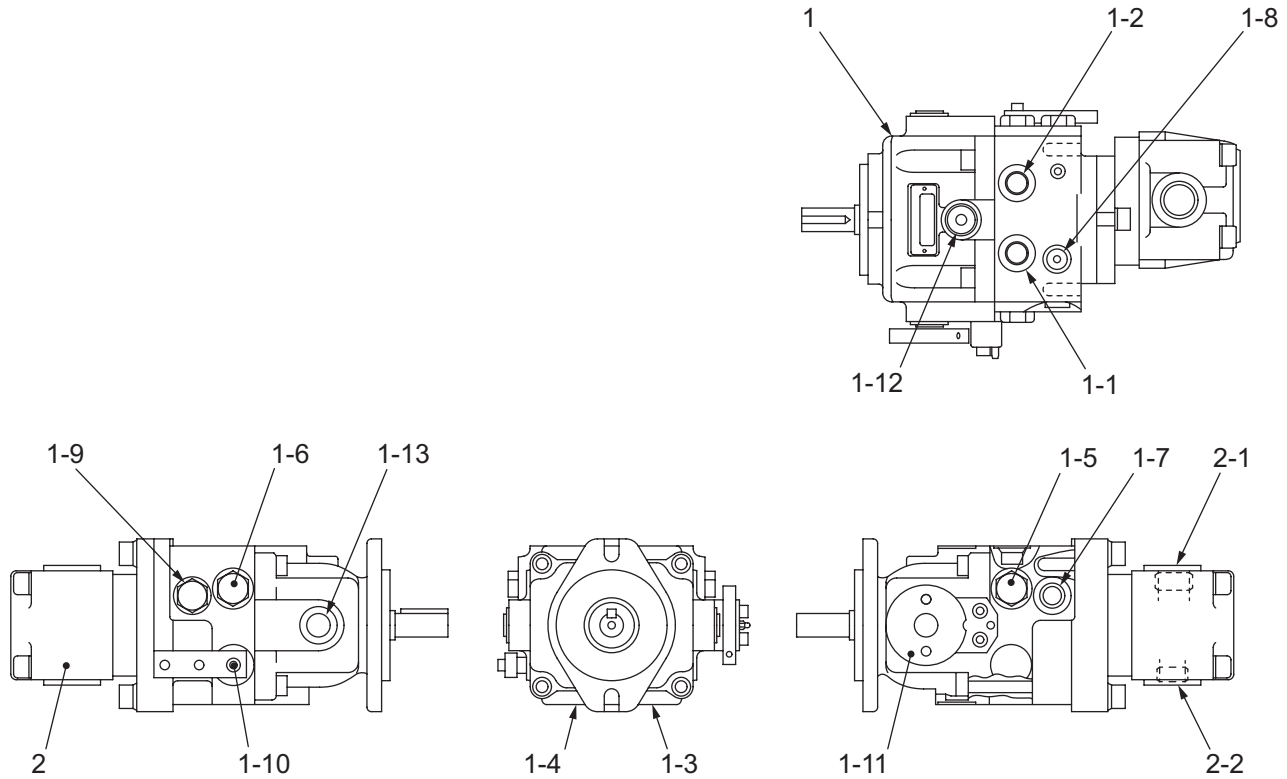

Pump circuit diagram

CR271-04001

(1) Propulsion pump

- (1-1) Port A (Forward) [PA] : G3/8
- (1-2) Port B (Reverse) [PB] : G3/8
- (1-3) High pressure gauge port (Port A) : 7/16-20UNF
- (1-4) High pressure gauge port (Port B) : 7/16-20UNF
- (1-5) High pressure relief valve (Port A)
- (1-6) High pressure relief valve (Port B)
- (1-7) Charge supply port [PC] : G3/8
- (1-8) Charge pressure gauge port : 7/16-20UNF
- (1-9) Charge supply port
- (1-10) Bypass valve
- (1-11) Forward-reverse control lever
- (1-12) Drain port [PD] : G3/8
- (1-13) Drain port : G3/8

Specifications

- Displacement : 10.0 cm³/rev (0.61 cu.in./rev)
- High pressure relief valve pressure setting : 17.2 MPa (2,494 psi)
- Charge relief valve pressure setting : 0.5 MPa (72.5 psi)

(2) Vibrator/steering/charge pump

- (2-1) Suction port [VSC] G3/4
- (2-2) Discharge port [VCO] : G1/2

Specification

- Displacement : 11 cm³/rev (0.67 cu.in./rev)
- Allowable pump case pressure : 0.1 MPa (14.5 psi)
- Pump assembly weight : 14 kg (31 lbs.)

2-2-3. Valve block

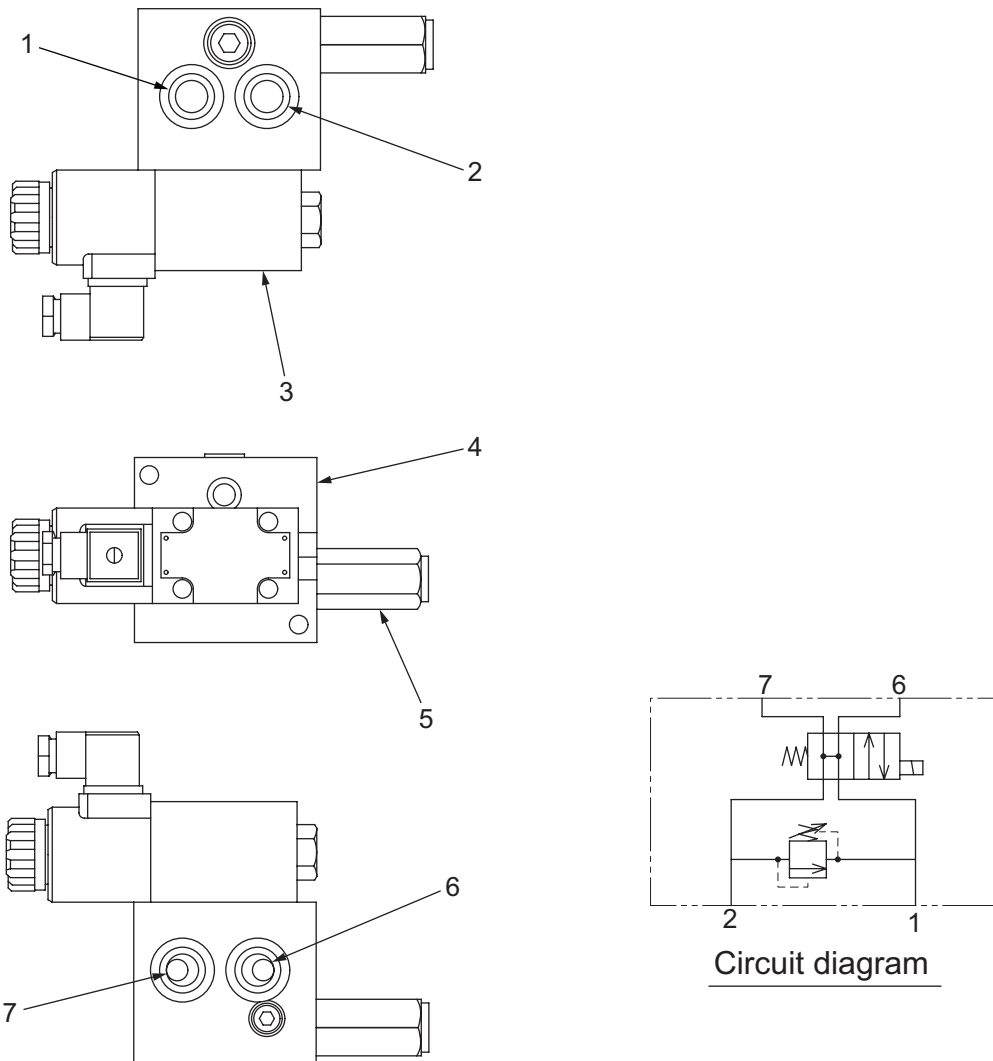

CR271-04003

- | | | |
|--------------------|--------------|-----------|
| (1) Port T | : | 3/4-16UNF |
| (2) Port P | [VBP] | 3/4-16UNF |
| (3) Solenoid valve | | |
| (4) Manifold block | | |
| (5) Relief valve | | |
| (6) Port B | [VBB] | 3/4-16UNF |
| (7) Port A | [VBA] | 3/4-16UNF |

Specifications

- Maximum pressure : 17.9 MPa (2,596 psi) (4, 5)
: 32 MPa (4,640 psi) (3)
- Maximum flow : 35 L/min (9.2 gal/min) (4, 5)
: 42 L/min (11 gal/min) (3)
- Relief valve pressure setting : 14.4 MPa (2,088 psi)
- Weight : 3.5 kg (7.7 lbs.)

2-2-4. Valve

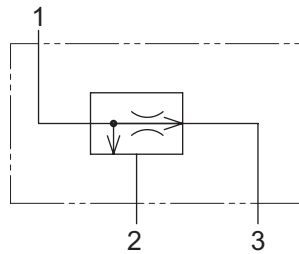
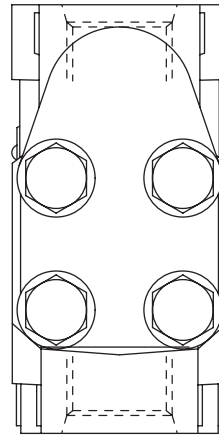
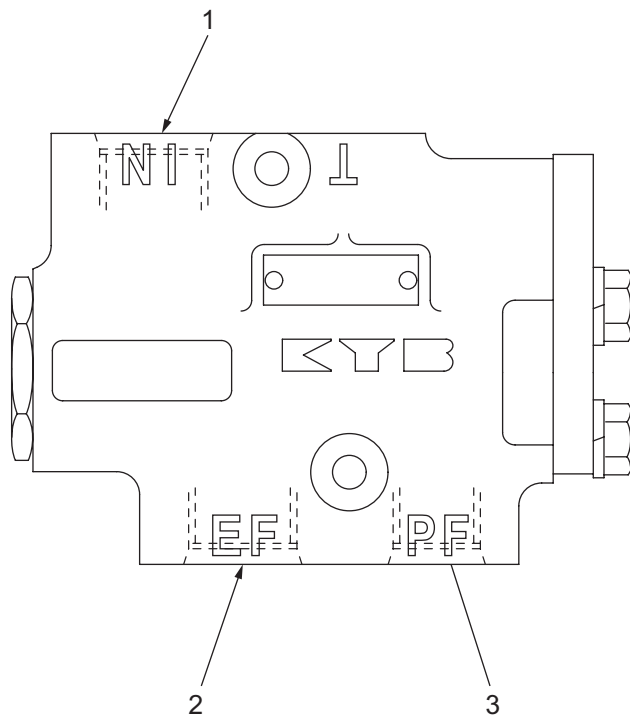

Circuit diagram

CR271-04004

- (1) Port IN **[IN]** : G1/2
- (2) Port EF **[EF]** : G1/2
- (3) Port PF **[PF]** : G3/8

Specifications

- Maximum pressure : 17.2 MPa (2,494 psi)
- Rated flow : 40 L/min (10.6 gal/min)
- Weight : 1.8 kg (1 lbs.)

3. VIBRATOR HYDRAULIC SYSTEM

3-1. Vibrator Hydraulic Piping

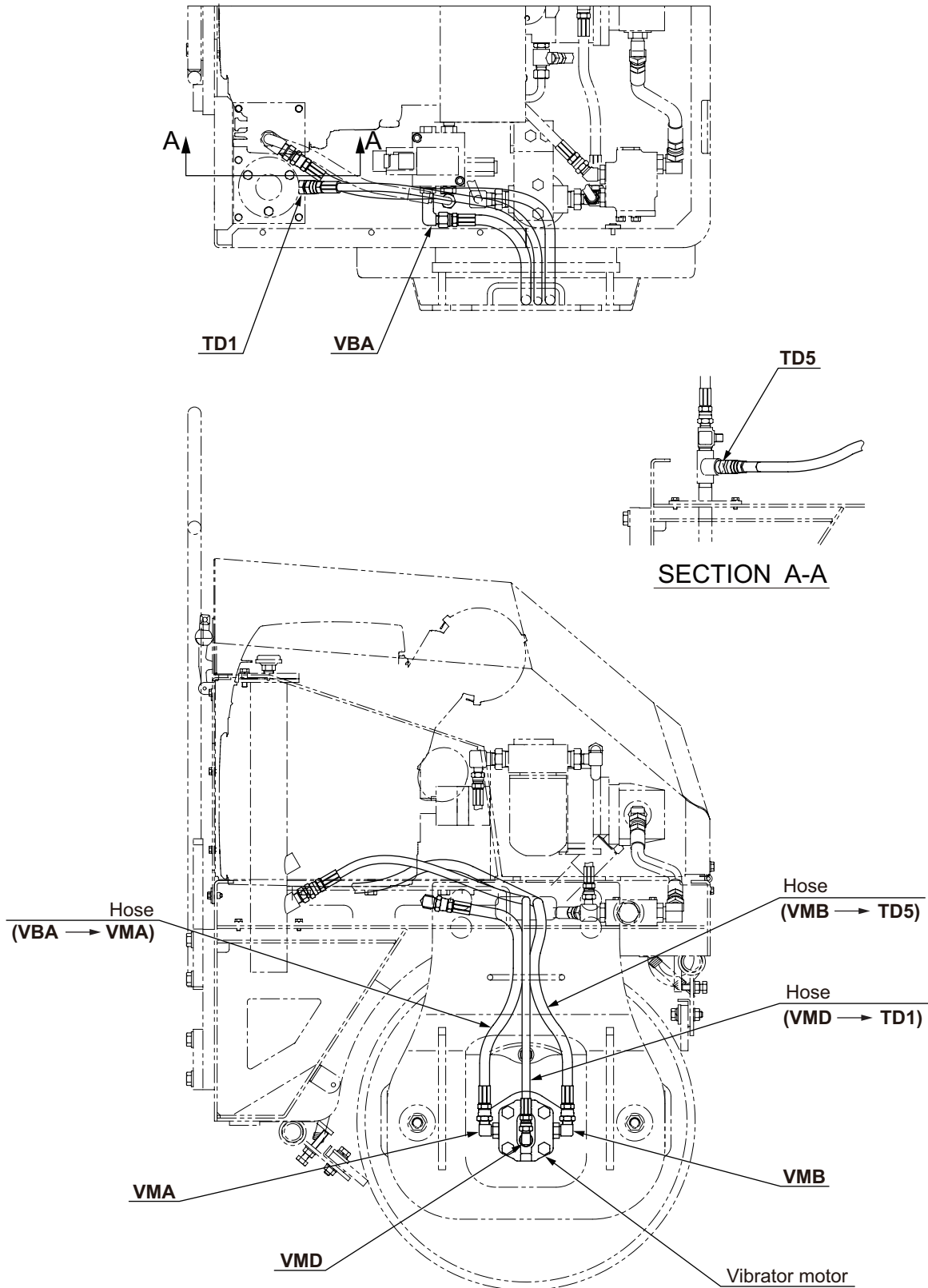

• The letters and figures (such as VMB and TD5) show each port and the arrow (→) symbols show the hose connection and the direction of the flow of the oil.

3-2. Hydraulic Component Specification

3-2-1. Vibrator hydraulic motor

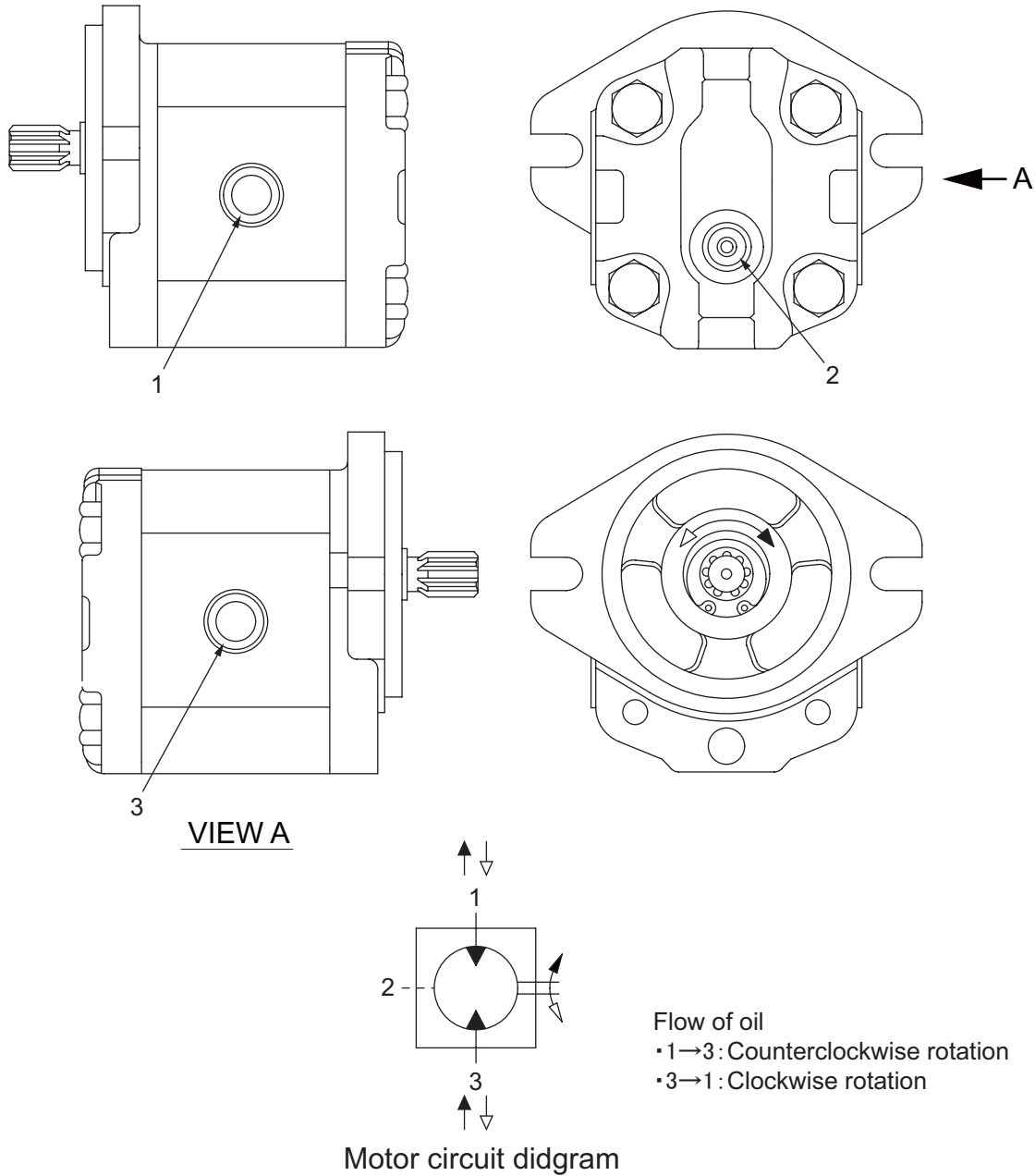

Motor circuit didgram

CR271-04005

- | | | |
|----------------|--------------|--------------|
| (1) Port A | [VMA] | : 7/8-14UNF |
| (2) Drain port | [VMD] | : 9/16-18UNF |
| (3) Port B | [VMB] | : 7/8-14UNF |

Specifications

- | | | |
|------------------|---|--------------------------------------------|
| • Displacement | : | 6 cm ³ /rev (0.37 cu.in./rev) |
| • Rated pressure | : | 25 MPa (3,625 psi) |
| • Weight | : | 2.4 kg (5.3 lbs.) |

4. STEERING SYSTEM

4-1. Steering Hydraulic Piping

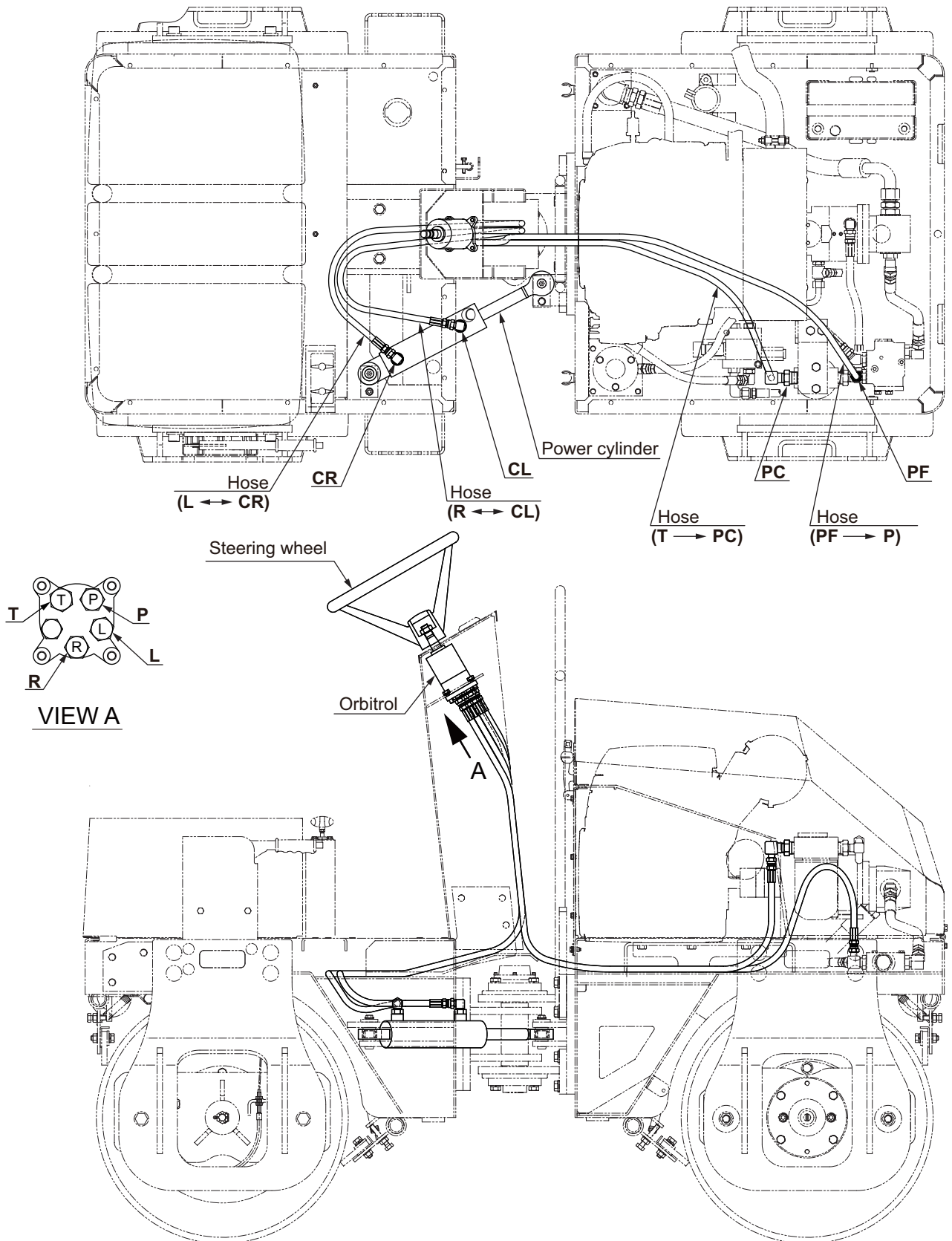

0563-32801-0-10183-D

- The letters and figures (such as L and CR) show each port and the arrow (↔ ; →) symbols show the hose connection and the direction of the flow of the oil.

4-2. Hydraulic Component Specifications

4-2-1. Orbitrol

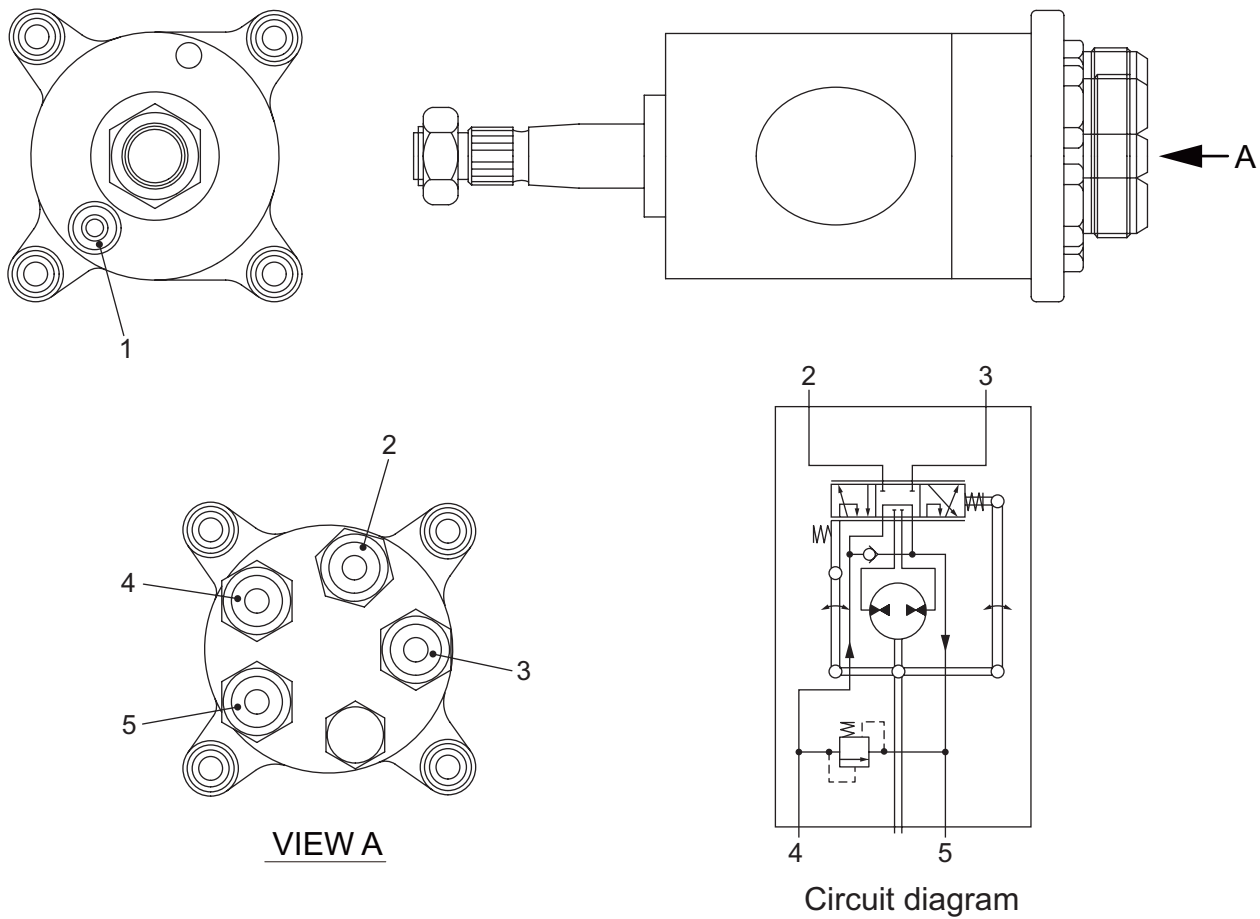

CR271-04006

- (1) Relief valve
- (2) Port L **[L]** : G1/4
- (3) Port R **[R]** : G1/4
- (4) Port P **[P]** : G1/4
- (5) Port T **[T]** : G1/4

Specifications

- Displacement : 50 cm³/rev (3 cu.in./rev)
- Relief valve pressure setting : 8 to 8.5 MPa (1160 to 1233 psi)
- Weight : 2.5 kg (5.5 lbs.)

4-3. Frame (Center Pin)

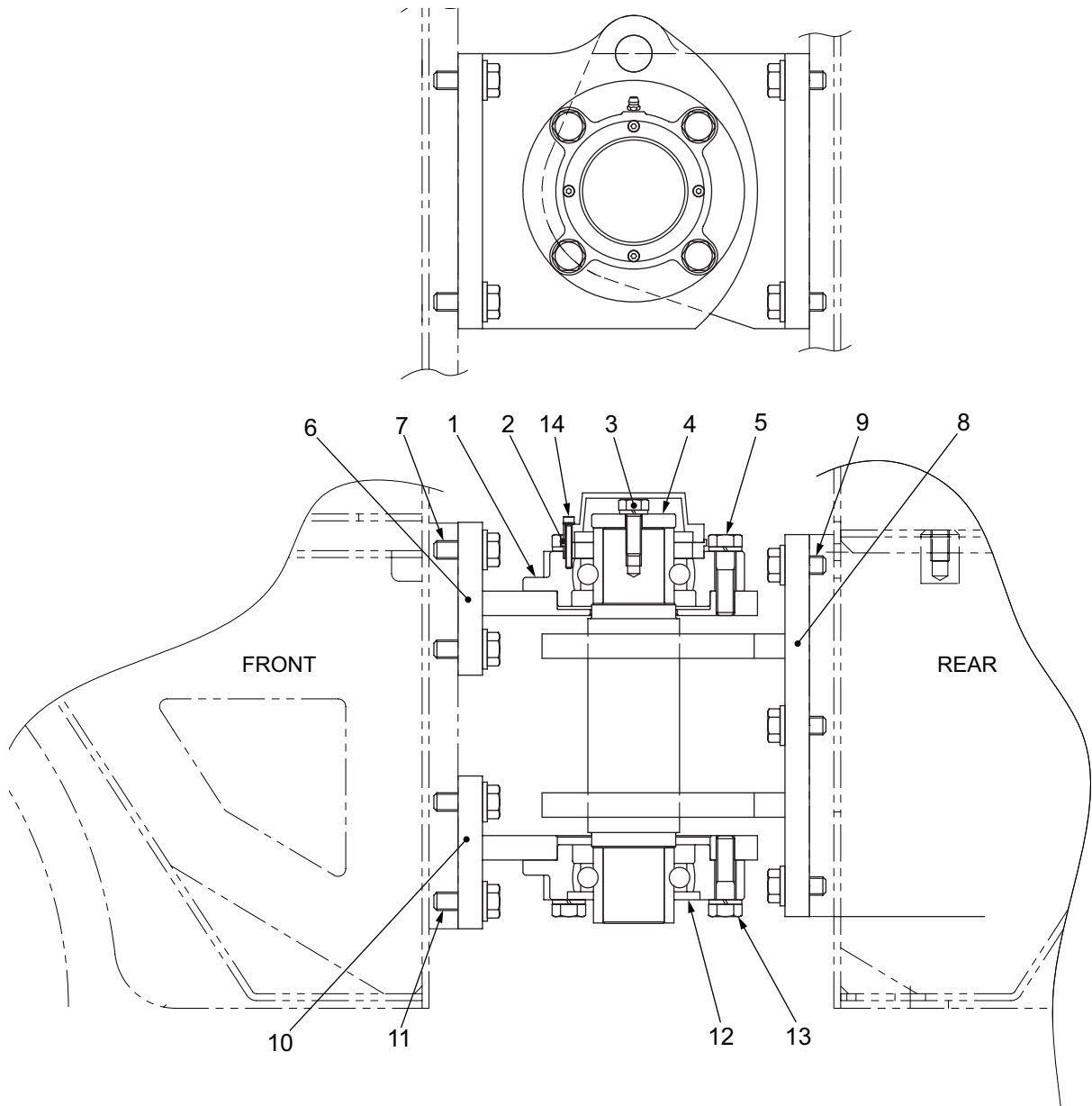

0563-61801-0-20175-C

- | | | |
|-------------------|-------------------|--------------------|
| (1) Bearing unit | (6) Bracket | (11) Bolt : M12x35 |
| (2) Adapter | (7) Bolt : M12x35 | (12) Bearing unit |
| (3) Bolt : M10x30 | (8) Bracket | (13) Bolt : M12x45 |
| (4) Washer | (9) Bolt : M12x30 | (14) Bolt : M4x30 |
| (5) Bolt : M12x45 | (10) Bracket | |



- | | |
|------------------|------------------------|
| (3) Bolt M10x30 | : 49 N·m (36 lbf·ft) |
| (5) Bolt M12x45 | : 78 N·m (58 lbf·ft) |
| (7) Bolt M12x35 | : 98 N·m (72 lbf·ft) |
| (9) Bolt M12x30 | : 98 N·m (72 lbf·ft) |
| (13) Bolt M12x45 | : 78 N·m (58 lbf·ft) |

5. SYSTEM CIRCUIT DIAGRAM (* :FROM 20552)

5-1. Hydraulic Circuit Diagram

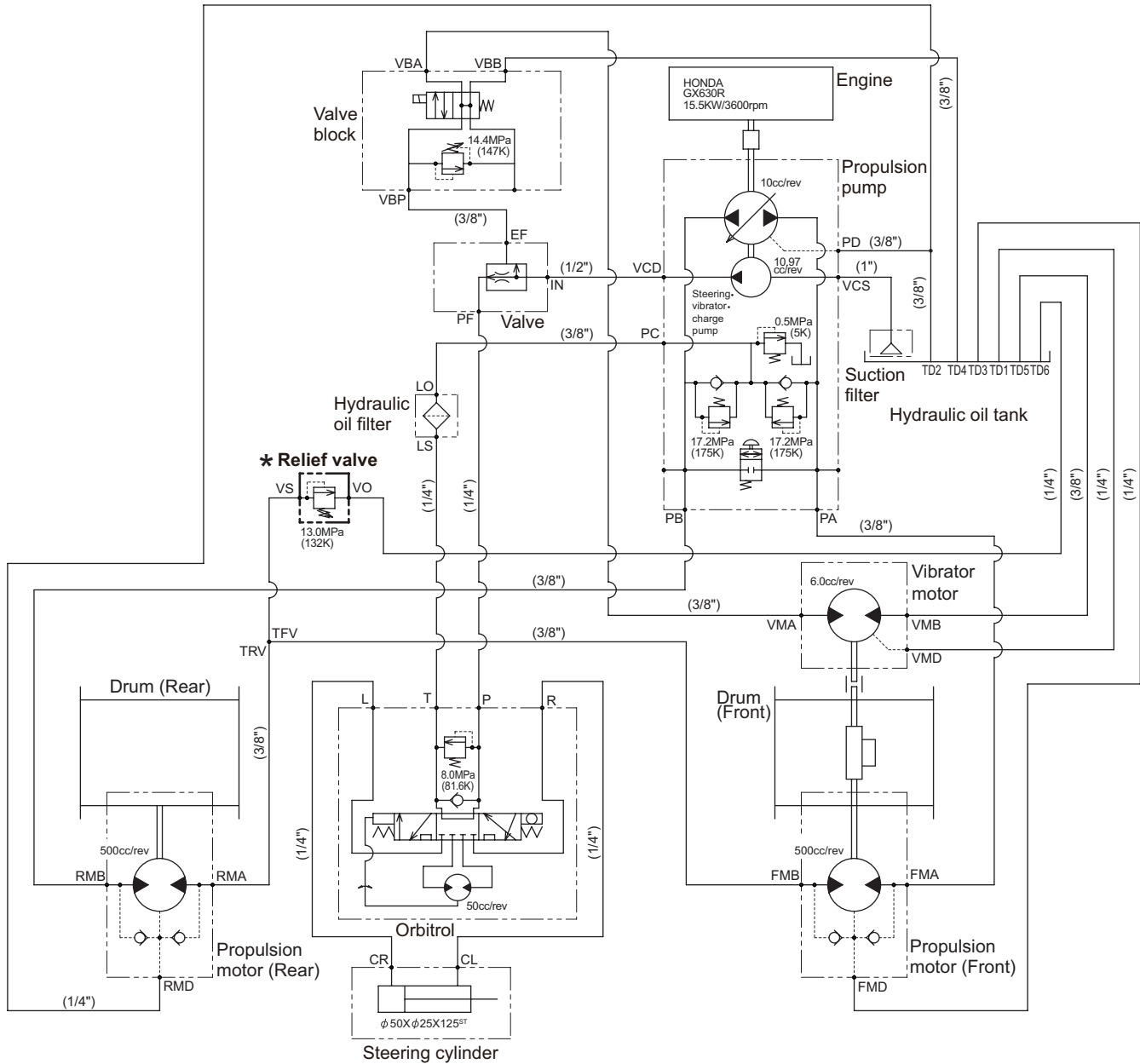

6. PROPULSION HYDRAULIC SYSTEM (* :FROM 20552)

6-1. Propulsion Hydraulic Piping (2)

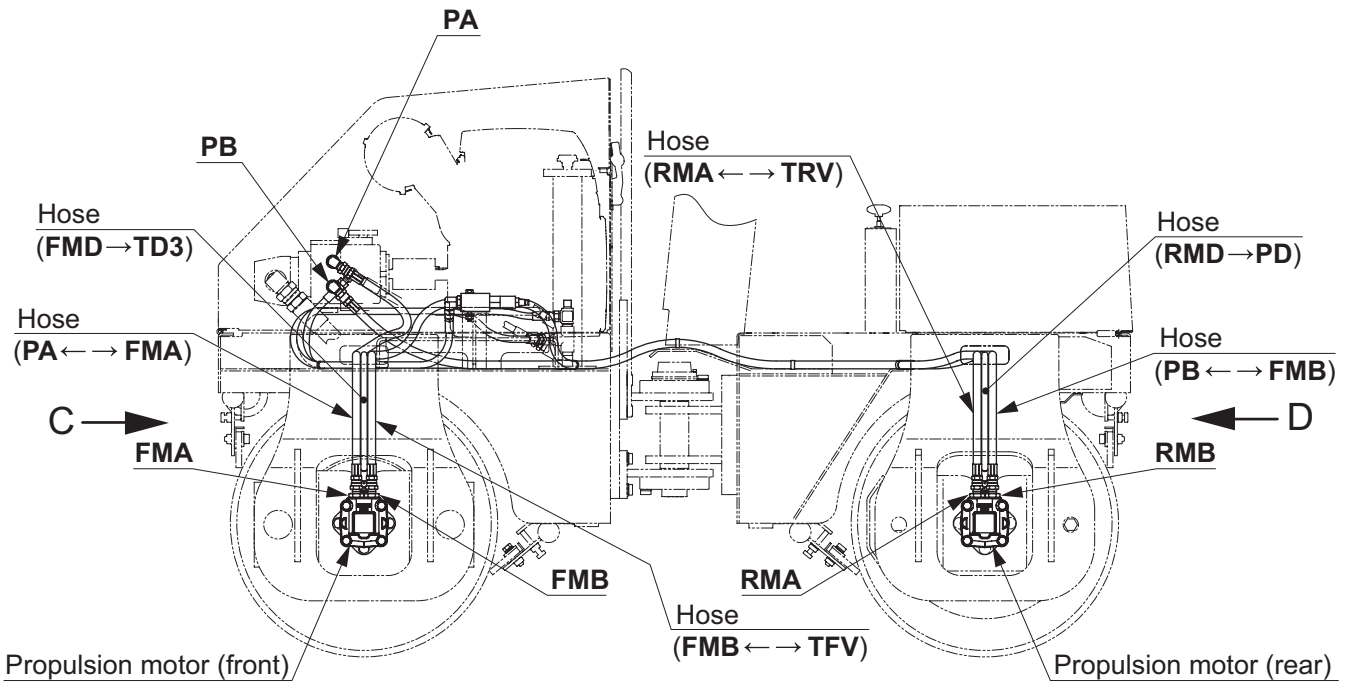
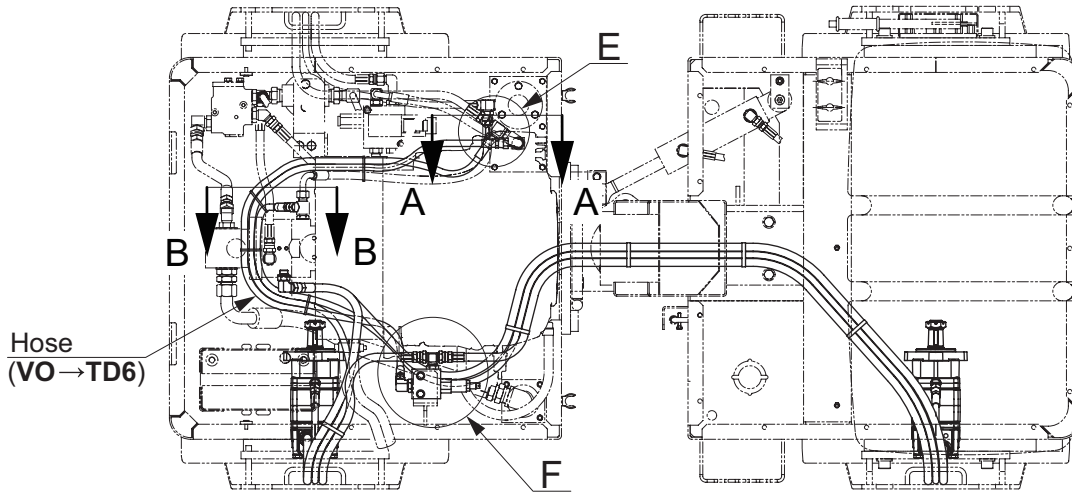

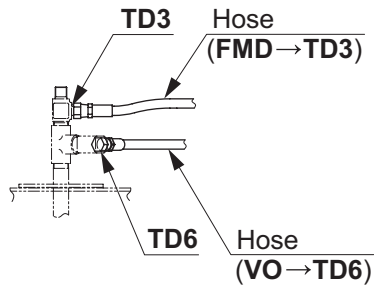

SECTION A-A

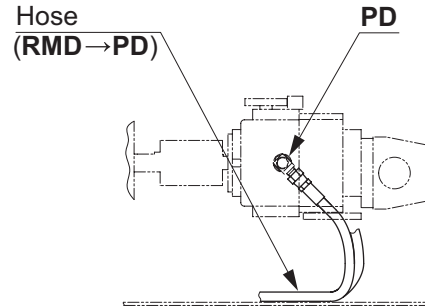

SECTION B-B

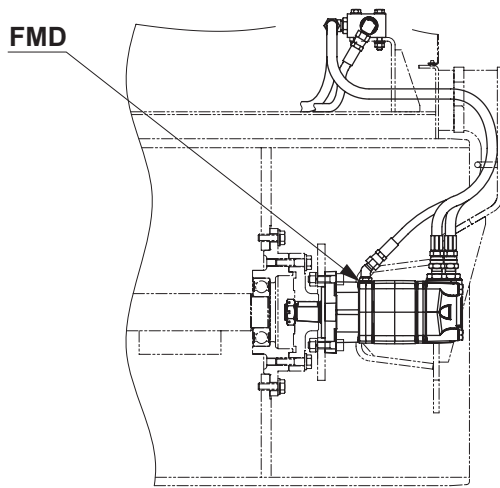

VIEW C

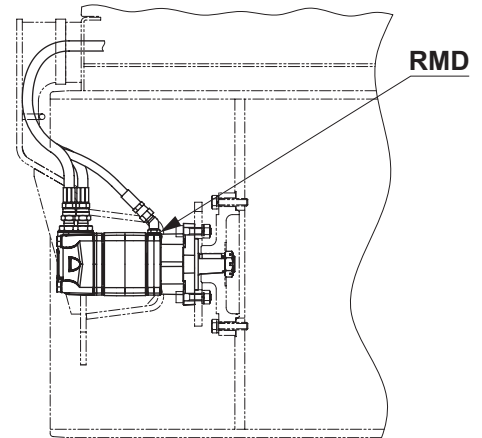

VIEW D

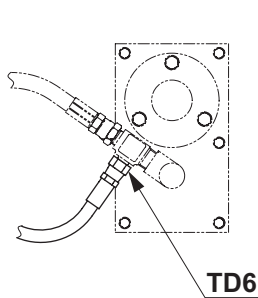

*DETAIL E

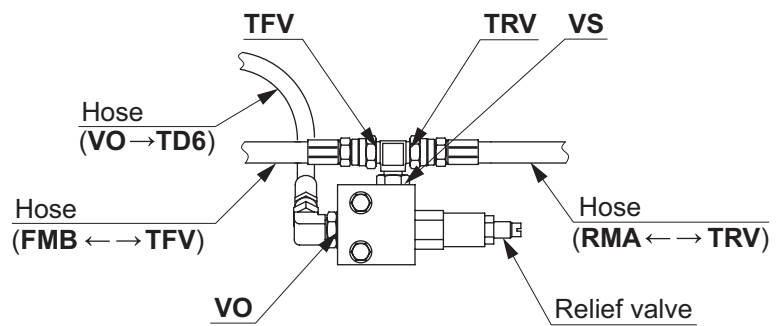

*DETAIL F

- The letters and numbers in the figure such as “FMB” and “TFV” show each port.
- Arrow “ \longleftrightarrow ; \rightarrow ” symbols show the hose connection and the direction of the flow of the oil.

6-2. Hydraulic Component Specifications

6-2-1. Relief valve

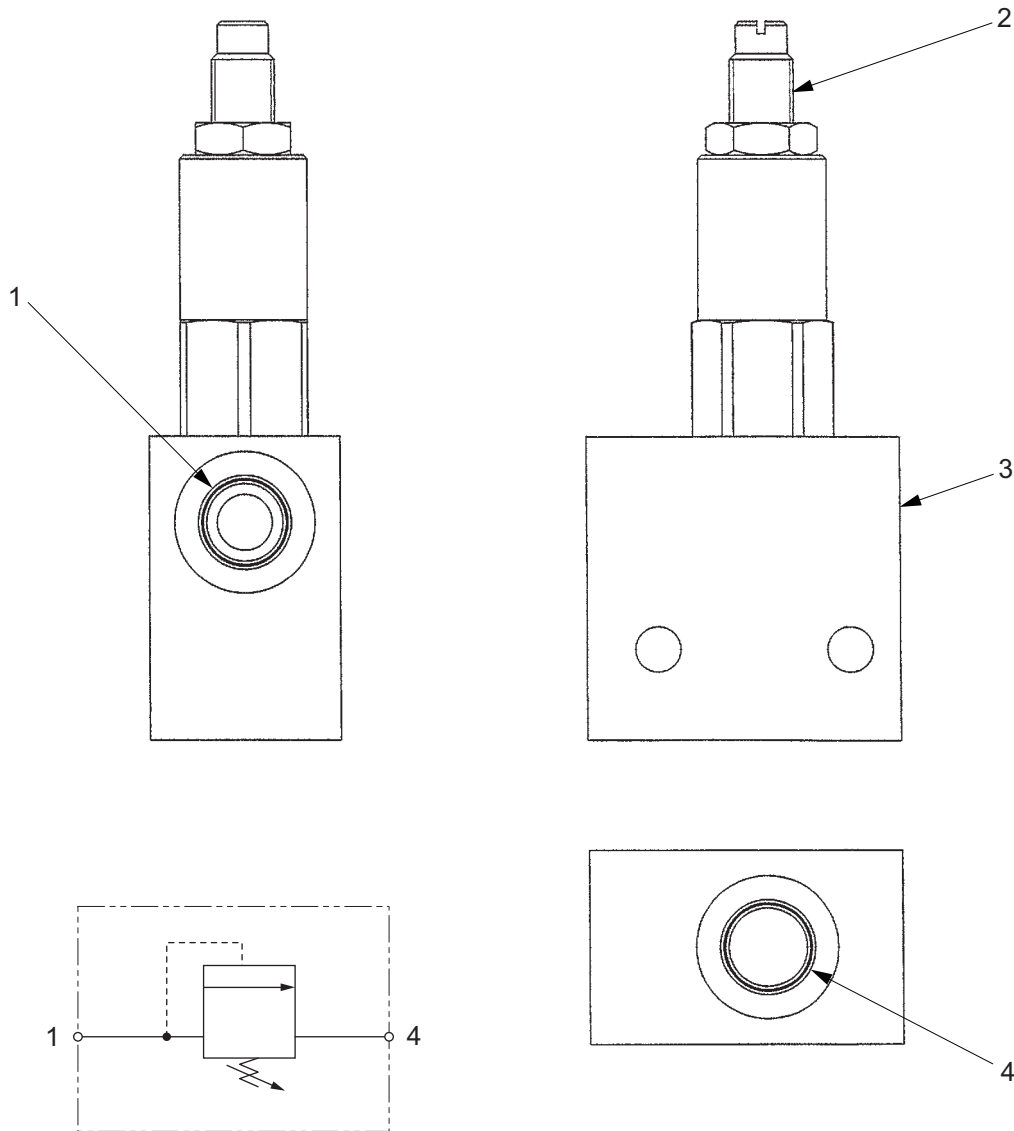

Hydraulic circuit diagram

CR271-04007

- (1) Port **[VS]** : G3/8
- (2) Relief valve
- (3) System block
- (4) Port **[VO]** : G3/8

Specifications

- Maximum pressure : 21 MPa (3,045 psi)
- Maximum flow : 57 L/min (15.1 gal/min)
- Relief valve pressure setting : 13 MPa (1,885 psi)
- Weight : 0.7 kg (1.5 lbs.)

7. VIBRATOR HYDRAULIC SYSTEM (* :FROM 20552)

7-1. Vibrator Hydraulic Piping

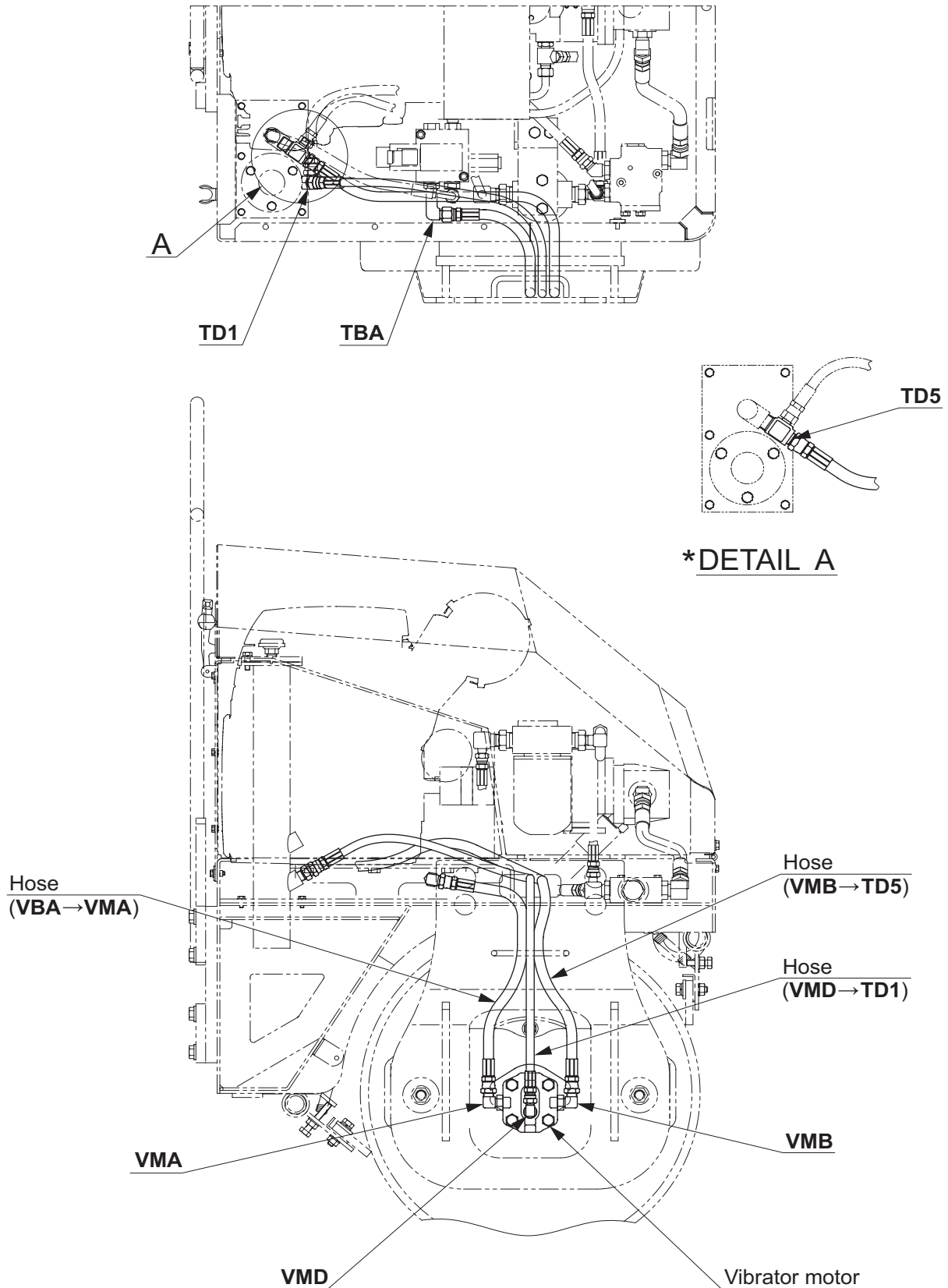

- The letters and numbers in the figure such as “VMB” and “TD5” show each port.
- Arrow “→” symbols show the hose connection and the direction of the flow of the oil.

ELECTRICAL SYSTEM

1. PRECAUTIONS FOR WORK

1-1. Wire Numbers, Wire Sizes, Wire Colors and Connectors Shown in Electrical Circuit Diagram, Wiring Harness Layout and Wiring Harnesses

- Codes used in electrical circuit diagrams give the following information.
- The wire size is AVS 0.85 unless otherwise specified.

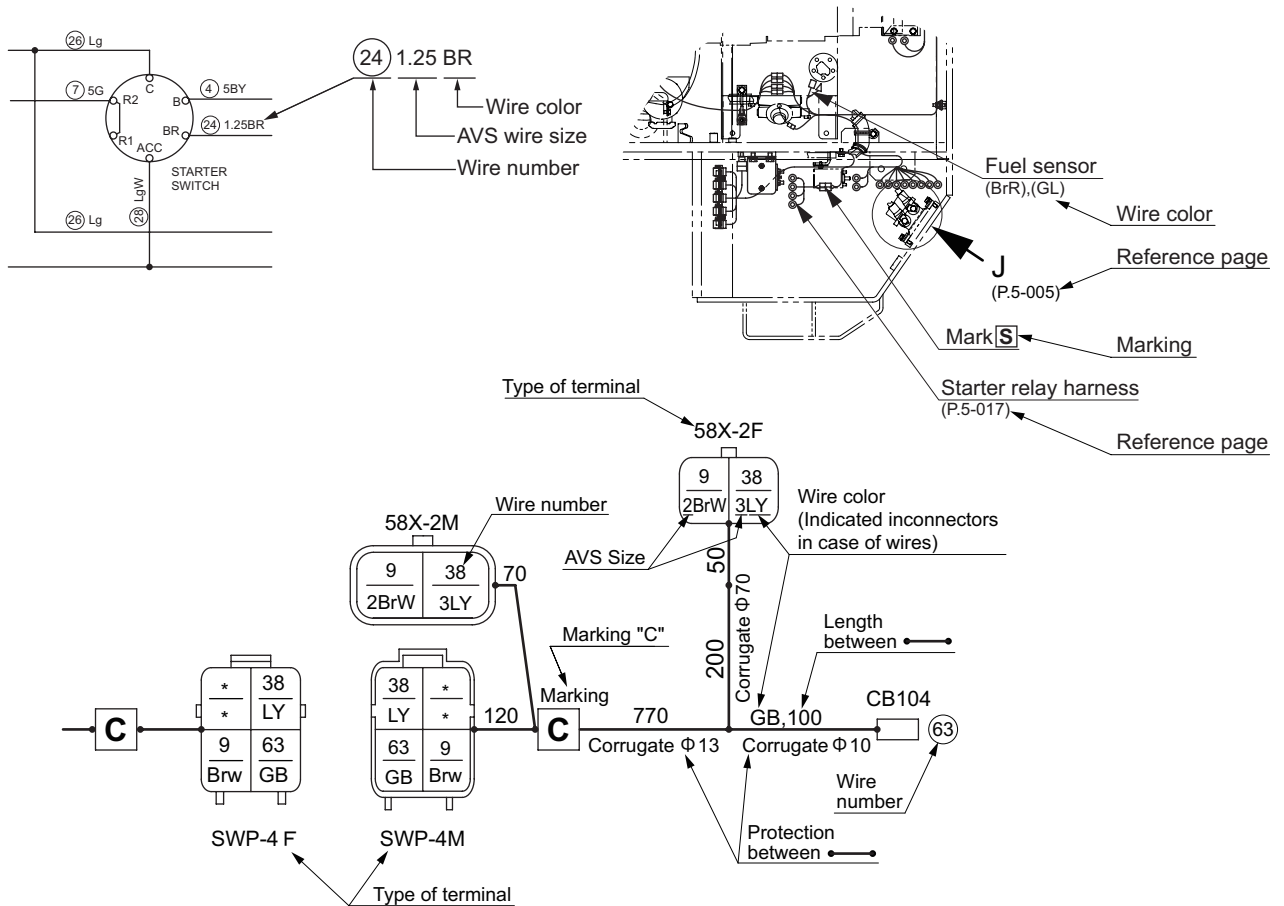

- The pin or socket layout of mating connectors are symmetrical, either vertically or horizontally. When the connector valves are connected, the pin and socket that have the same number are connected.

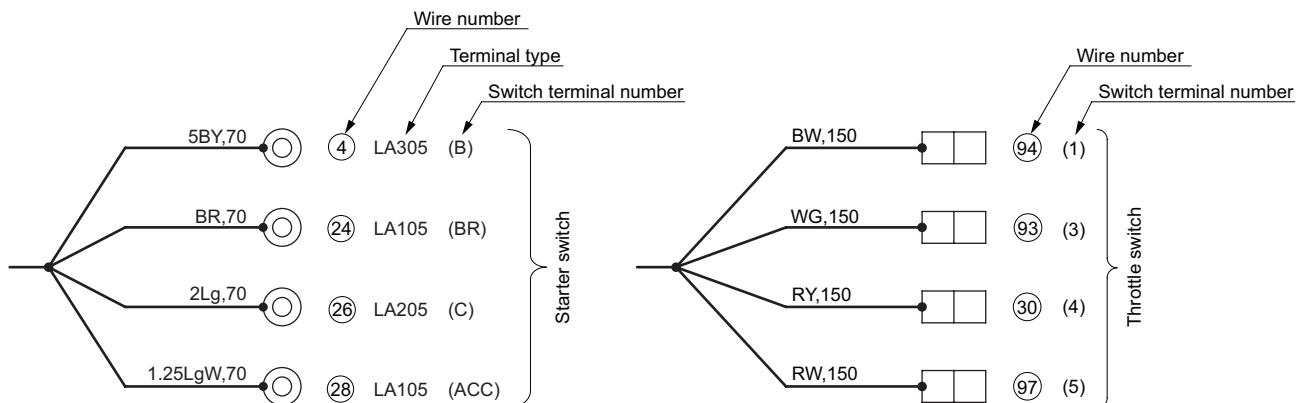

ELECTRICAL SYSTEM

- Wire color code chart

B	Black	BW	Black/ White stripe	BY	Black/ Yellow stripe	BR	Black/ Red stripe	BG	Black/ Green stripe	BL	Black/ Blue stripe			O	Orange	YO	Yellow/ Orange stripe
W	White	WR	White/ Red stripe	WB	White/ Black stripe	WL	White/ Blue stripe	WY	White/ Yellow stripe	WG	White/ Green stripe					LO	Blue/ Orange stripe
R	Red	RW	Red/ White stripe	RB	Red/ Black stripe	RY	Red/ Yellow stripe	RG	Red/ Green stripe	RL	Red/ Blue stripe					GO	Green/ Orange stripe
G	Green	GW	Green/ White stripe	GR	Green/ Red stripe	GY	Green/ Yellow stripe	GB	Green/ Black stripe	GL	Green/ Blue stripe			Gy	Gray	GyR	Gray/ Red stripe
Y	Yellow	YR	Yellow/ Red stripe	YB	Yellow/ Black stripe	YG	Yellow/ Green stripe	YL	Yellow/ Blue stripe	YW	Yellow/ White stripe					GyL	Gray/ Blue stripe
Br	Brown	BrW	Brown/ White stripe	BrR	Brown/ Red stripe	BrY	Brown/ Yellow stripe	BrB	Brown/ Black stripe	BrG	Brown/ Green stripe	BrL	Brown/ Blue stripe	Sb	Sky blue		
L	Blue	LW	Blue/ White stripe	LR	Blue/ Red stripe	LY	Blue/ Yellow stripe	LB	Blue/ Black stripe	LG	Blue/ Green stripe			P	Pink	PB	Pink/ Black stripe
Lg	Light green	LgR	Light green/ Red stripe	LgY	Light green/ Yellow stripe	LgB	Light green/ Black stripe	LgW	Light green/ White stripe	LgL	Light green/ Blue stripe			Pu	Purple		

2. SYSTEM CIRCUIT DIAGRAM

2-1. Electrical Circuit Diagram

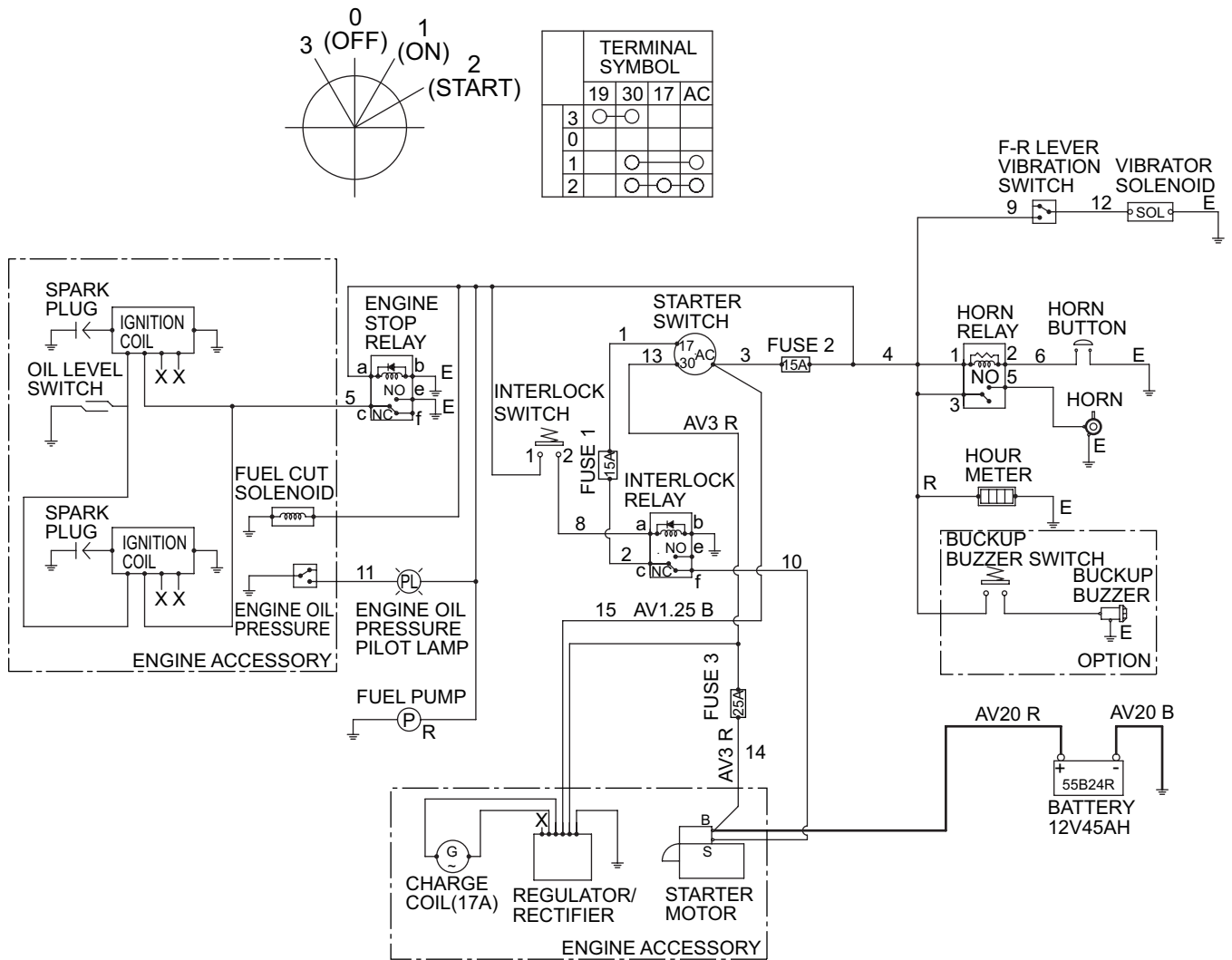

0563-99009-0-20460-0

- The wire size is AV 1.25 unless otherwise specified.

3. ELECTRICAL COMPONENTS

3-1. Electrical component Layout

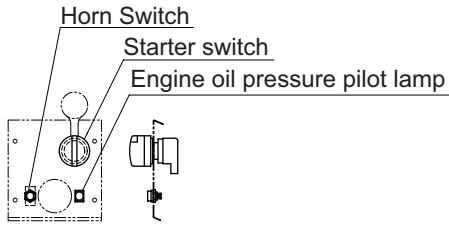

VIEW A

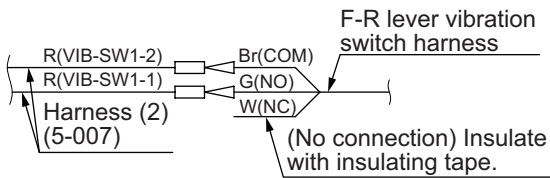
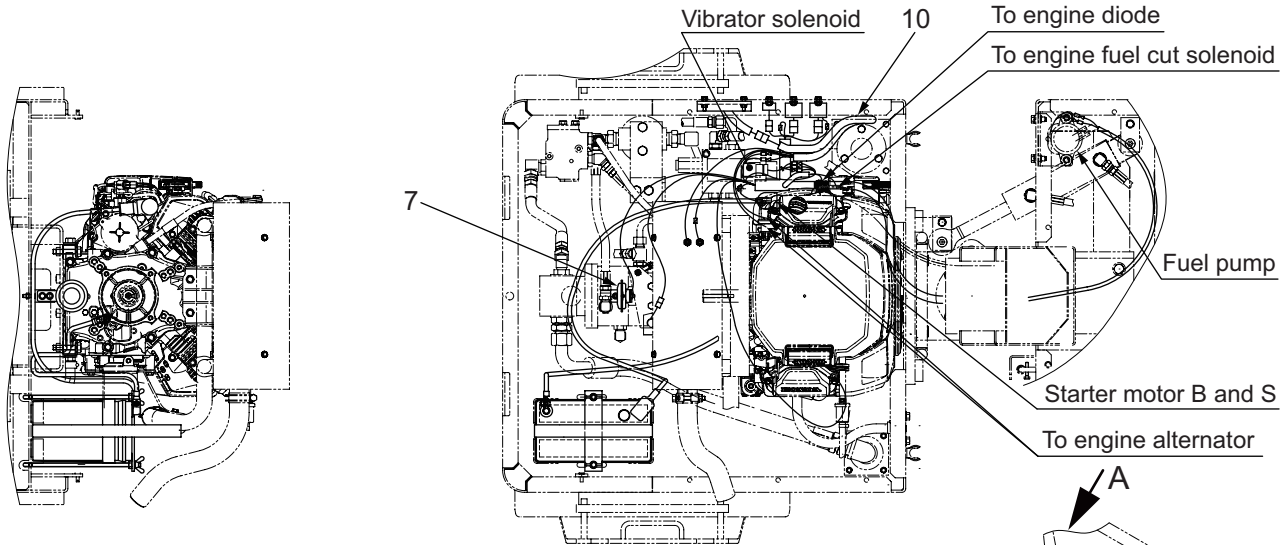
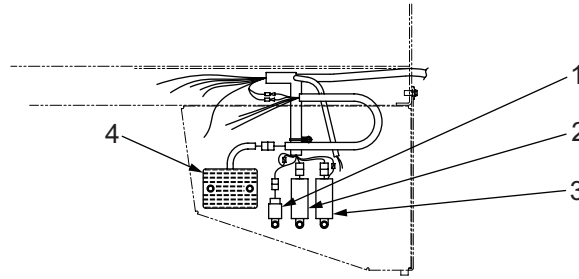

DETAIL B

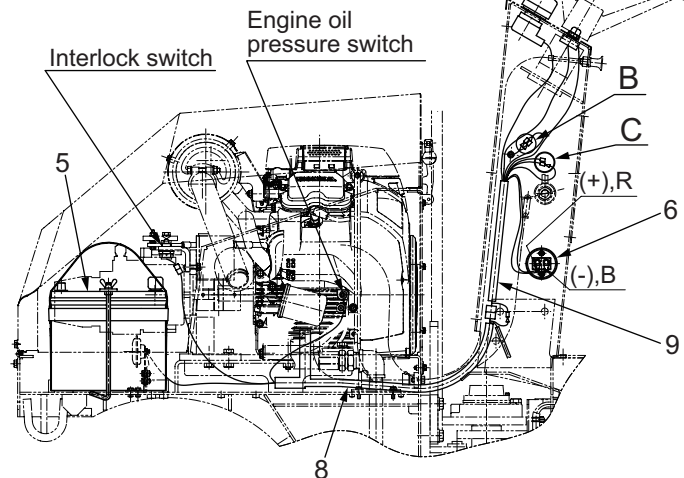

DETAIL C

- (1) Horn relay
- (2) Engine stop relay
- (3) Interlock relay
- (4) Regulator unit
- (5) Battery
- (6) Hour meter
- (7) Horn
- (8) Harness (1)
- (9) Harness (2)
- (10) Harness (Engine accessory)

0563-09803-0-10286-C

4. WIRING HARNESS

4-1. Harness (1)

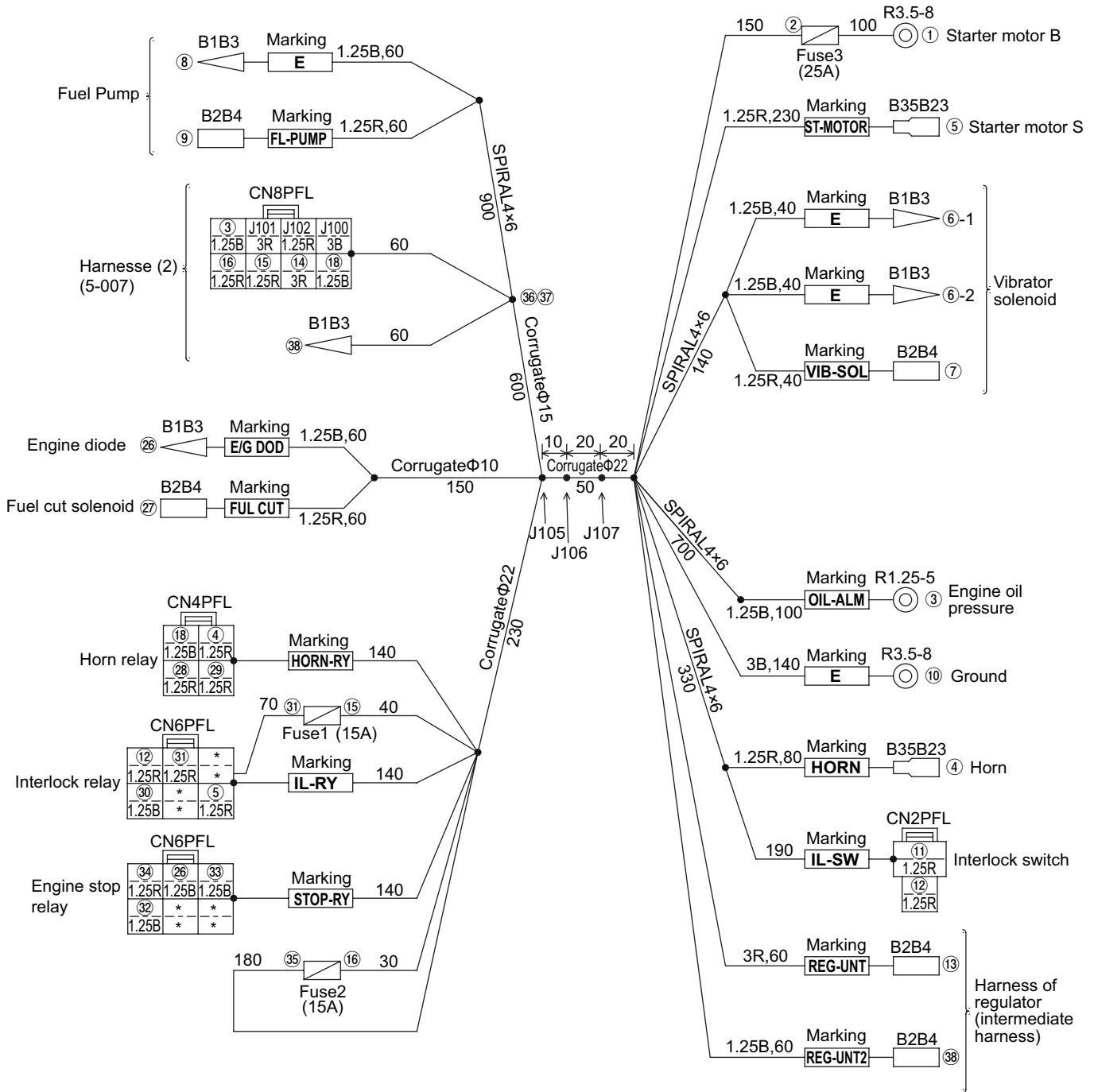

CR271-05001

NO.	SIZW,COLOR	CONTACT POINTS	CONNECTION	Line number of electric wiring diagram
①	3R	2	Fuse-3(25A), Starter motor-B	14
②	3R	2	Fuse-3(25A), Joint-107	13
③	1.25B	2	Engine oil pressure switch, Connector-CN8PFL(to Harness (2))	11
④	1.25R	2	HORN-RY , Horn	7
⑤	1.25R	2	IL-RY , Starter motor-S	10
⑥ -1	1.25B	2	E -Vibrator solenoid, Joint-105	E
⑥ -2	1.25B	2	E -Vibrator solenoid, Joint-105	E
⑦	1.25R	2	VIB-SOL -Vibrator solenoid, Joint-102	12
⑧	1.25B	2	E -Fuel pump, Joint-105	E
⑨	1.25R	2	FL-PUMP -Fuel pump, Joint-106	4
⑩	3B	2	E -Ground, Joint-105	E
⑪	1.25R	2	IL-SW , Joint-106	4
⑫	1.25R	2	IL-SW , IL-RY	8
⑬	3R	2	REG-UNT , Joint-107	13
⑭	3R	2	Connector-CN8PFL(to Harness (2)), Joint-107	13
⑮	1.25R	2	Connector-CN8PFL(to Harness (2)), Fuse-1(15A)	1
⑯	1.25R	2	Connector-CN8PFL(to Harness (2)), Fuse-2(15A)	3
⑰	1.25B	2	HORN-RY , Connector-CN8PFL(to Harness (2))	6
⑳	1.25B	2	E/G-DOD , STOP-RY	5
㉑	1.25R	2	FUL-CUT , Joint-106	4
㉒	1.25R	2	HORN-RY , Joint-106	4
㉓	1.25R	2	HORN-RY , Joint-106	4
㉔	1.25B	2	IL-RY , Joint-105	E
㉕	1.25R	2	IL-RY , Fuse-1(15A)	2
㉖	1.25B	2	STOP-RY , Joint-105	E
㉗	1.25B	2	STOP-RY , Joint-105	E
㉘	1.25R	2	STOP-RY , Joint-106	4
㉙	1.25R	2	Fuse-2(15A), Joint-106	4
㉚	3B	2	Connector-CN8PFL(to Harness (2))-Joint-100, Joint-105	E
㉛	1.25R	2	Connector-CN8PFL(to Harness (2))-Joint-101, Joint-106	4
㉜	1.25B	2	REG-UNT2 , to Harness (2)	15

4-2. Harness (2)

4-2-1. Harness (* :to 20293, from 20318 to 20329)

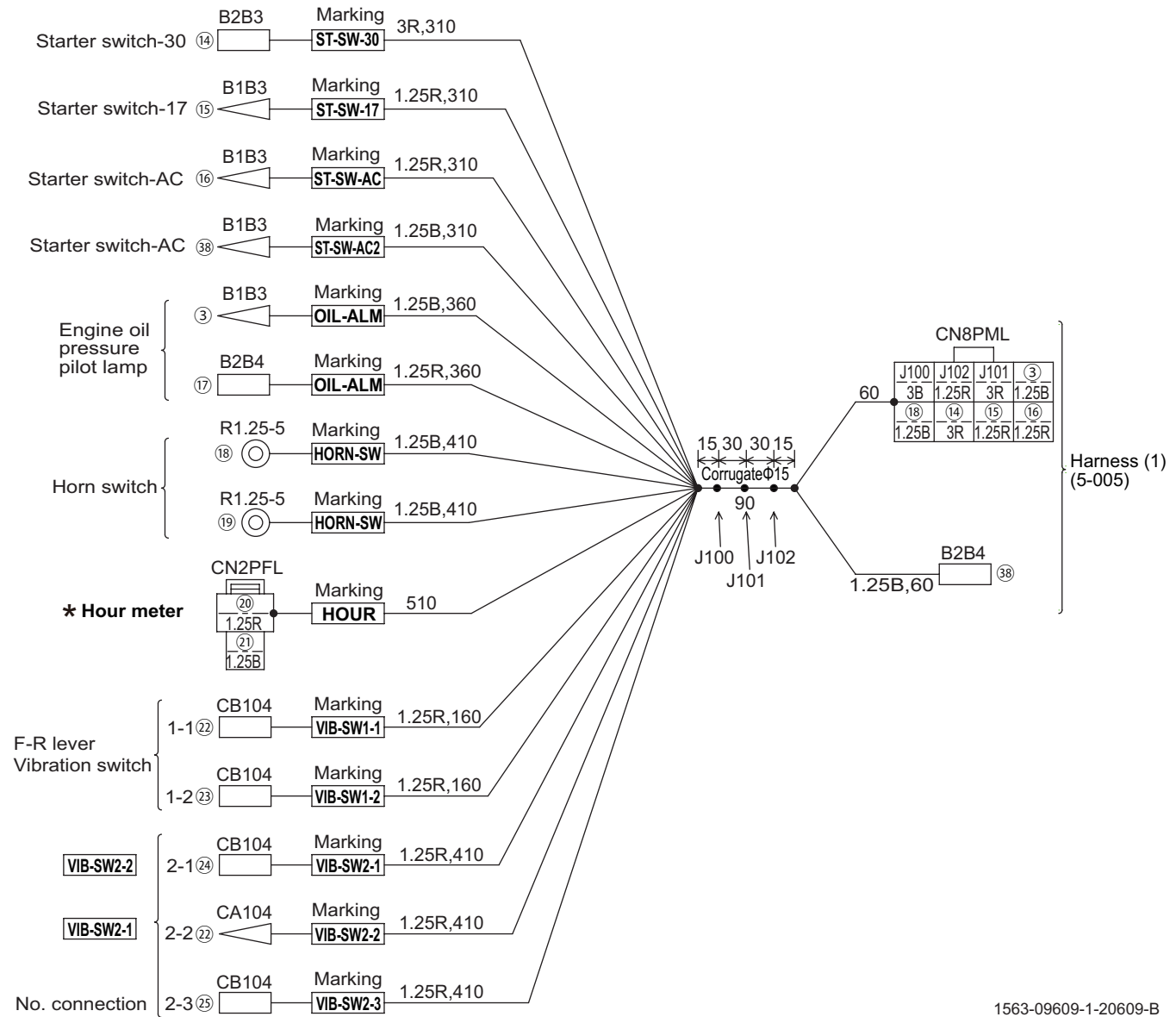

1563-09609-1-20609-B

NO.	SIZW,COLOR	CONTACT POINTS	CONNECTION	Line number of electric wiring diagram
③	1.25B	2	OIL-ALM -Engine oil pressure pilot lamp, Connector-CN8PFL(to Harness (1))	11
⑭	3R	2	ST-SW-30 , Connector-CN8PFL(to Harness (1))	13
⑮	1.25R	2	ST-SW-17 , Connector-CN8PFL(to Harness (1))	1
⑯	1.25R	2	ST-SW-AC , Connector-CN8PFL(to Harness (1))	3
⑰	1.25R	2	OIL-ALM -Engine oil pressure pilot lamp, Joint-101	4
⑱	1.25B	2	HORN-SW -Horn switch, Connector-CN8PFL(to Harness (1))	6
⑲	1.25B	2	HORN-SW -Horn switch, Joint-100	E
⑳	1.25R	2	HOUR -Hour meter, Joint-101	4
㉑	1.25B	2	HOUR -Hour meter, Joint-100	E
㉒	1.25R	2	VIB-SW1-1 , VIB-SW2-2	9
㉓	1.25R	2	VIB-SW1-2 , Joint-102	12
㉔	1.25R	2	VIB-SW2-1 , Joint-101	4
㉕	1.25R	2	VIB-SW2-3 , Joint-102	12
㉘	1.25B	2	ST-SW-AC2 , to Harness (1)	15
J100	3B	2	Joint-100, Connector-CN8PFL(to Harness (1))-J100	
J101	3R	2	Joint-101, Connector-CN8PFL(to Harness (1))-J101	
J102	1.25R	2	Joint-102, Connector-CN8PFL(to Harness (1))-J102	

4-2-2. Harness (* :from 20294 to 20317, 20330)

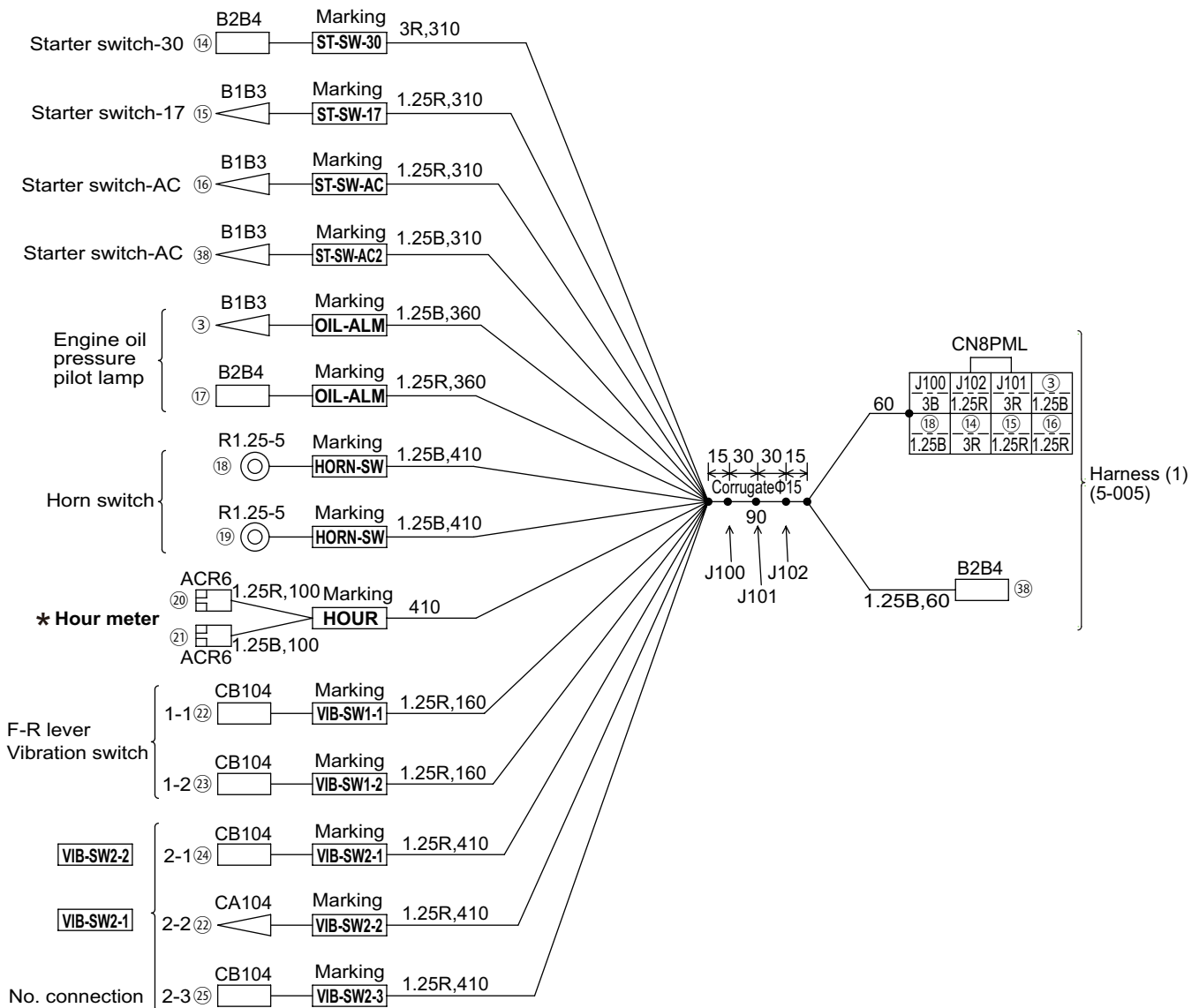

1563-09017-0-20574-0

NO.	SIZW,COLOR	CONTACT POINTS	CONNECTION	Line number of electric wiring diagram
③	1.25B	2	OIL-ALM -Engine oil pressure pilot lamp, Connector-CN8PFL(to Harness (1))	11
⑭	3R	2	ST-SW-30 , Connector-CN8PFL(to Harness (1))	13
⑮	1.25R	2	ST-SW-17 , Connector-CN8PFL(to Harness (1))	1
⑯	1.25R	2	ST-SW-AC , Connector-CN8PFL(to Harness (1))	3
⑰	1.25R	2	OIL-ALM -Engine oil pressure pilot lamp, Joint-101	4
⑱	1.25B	2	HORN-SW -Horn switch, Connector-CN8PFL(to Harness (1))	6
⑲	1.25B	2	HORN-SW -Horn switch, Joint-100	E
⑳	1.25R	2	HOUR -Hour meter, Joint-101	4
㉑	1.25B	2	HOUR -Hour meter, Joint-100	E
㉒	1.25R	2	VIB-SW1-1 , VIB-SW2-2	9
㉓	1.25R	2	VIB-SW1-2 , Joint-102	12
㉔	1.25R	2	VIB-SW2-1 , Joint-101	4
㉕	1.25R	2	VIB-SW2-3 , Joint-102	12
㉘	1.25B	2	ST-SW-AC2 , to Harness (1)	15
J100	3B	2	Joint-100, Connector-CN8PFL(to Harness (1))-J100	
J101	3R	2	Joint-101, Connector-CN8PFL(to Harness (1))-J101	
J102	1.25R	2	Joint-102, Connector-CN8PFL(to Harness (1))-J102	

4-2-3. Harness (* :From 20331)

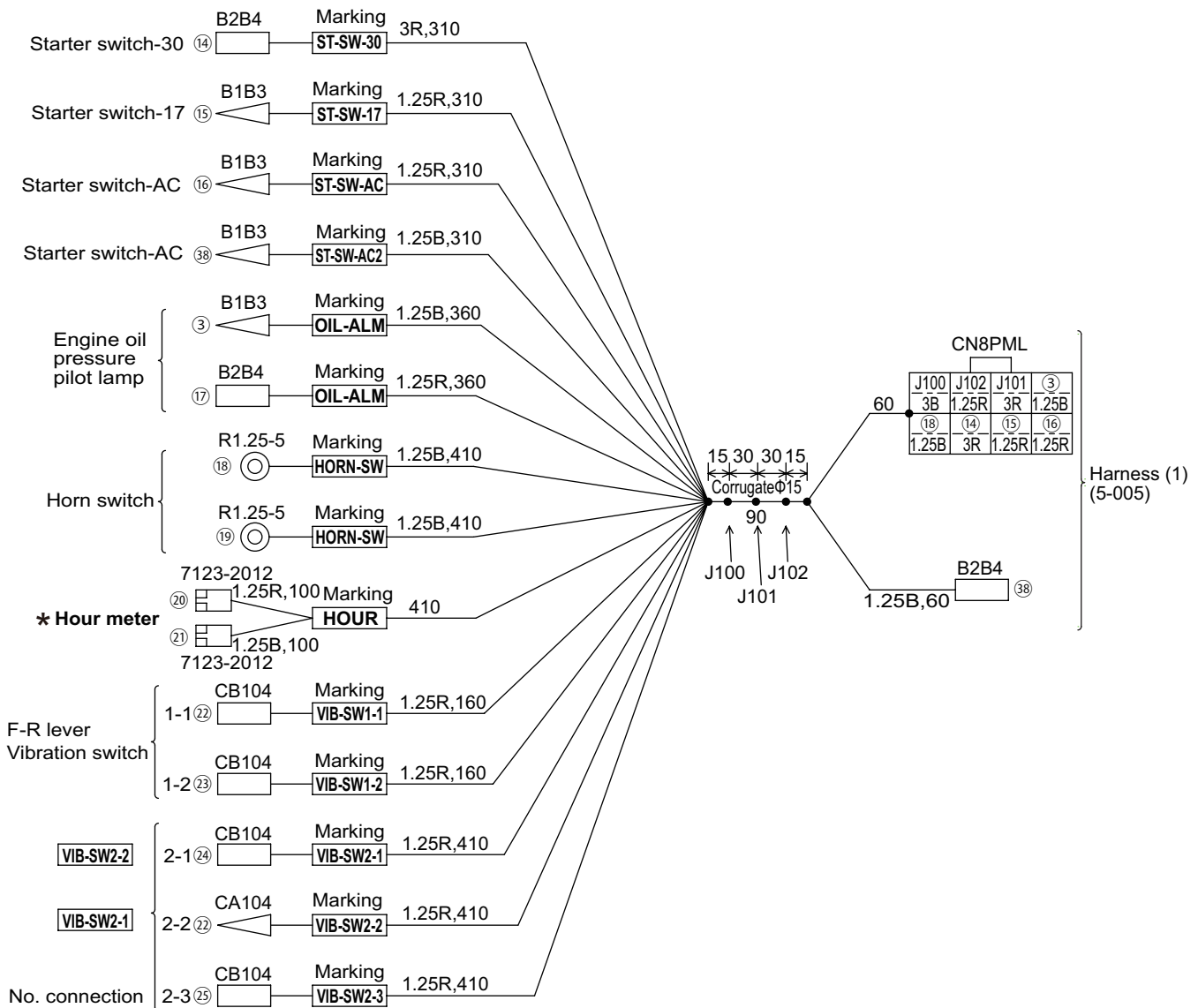

1563-09017-1-20574-A

NO.	SIZW,COLOR	CONTACT POINTS	CONNECTION	Line number of electric wiring diagram
③	1.25B	2	OIL-ALM -Engine oil pressure pilot lamp, Connector-CN8PFL(to Harness (1))	11
⑭	3R	2	ST-SW-30 , Connector-CN8PFL(to Harness (1))	13
⑮	1.25R	2	ST-SW-17 , Connector-CN8PFL(to Harness (1))	1
⑯	1.25R	2	ST-SW-AC , Connector-CN8PFL(to Harness (1))	3
⑰	1.25R	2	OIL-ALM -Engine oil pressure pilot lamp, Joint-101	4
⑱	1.25B	2	HORN-SW -Horn switch, Connector-CN8PFL(to Harness (1))	6
⑲	1.25B	2	HORN-SW -Horn switch, Joint-100	E
⑳	1.25R	2	HOUR -Hour meter, Joint-101	4
㉑	1.25B	2	HOUR -Hour meter, Joint-100	E
㉒	1.25R	2	VIB-SW1-1 , VIB-SW2-2	9
㉓	1.25R	2	VIB-SW1-2 , Joint-102	12
㉔	1.25R	2	VIB-SW2-1 , Joint-101	4
㉕	1.25R	2	VIB-SW2-3 , Joint-102	12
㉘	1.25B	2	ST-SW-AC2 , to Harness (1)	15
J100	3B	2	Joint-100, Connector-CN8PFL(to Harness (1))-J100	
J101	3R	2	Joint-101, Connector-CN8PFL(to Harness (1))-J101	
J102	1.25R	2	Joint-102, Connector-CN8PFL(to Harness (1))-J102	

DRUMS

1. PRECAUTIONS FOR DISASSEMBLY AND REASSEMBLY

- When removing, installing, disassembling or reassembling the unit, observe the general precautions described below.
- 1) Precautions for removal work
 - Coolant that contains antifreeze should be treated as a chemical, and must not be drained carelessly on the ground.
 - To prevent dust from getting into disconnected hoses and tubes, cover them with a plug or similar means.
 - When draining oil, use a receptacle with sufficient capacity to receive it.
 - Before proceeding with the work, look for matchmarks that show the installation location. For reassembly, place matchmarks in the required locations to prevent errors. Then remove.
 - When disconnecting wiring connectors, hold the connector components so that unreasonable force is not applied to the wires.
 - Label wires and hoses to ensure correct installation location.
 - Confirm the number and thickness of shims prior to storage.
 - When lifting parts, use lifting equipment of sufficient capacity.
 - When separating parts by using pull bolts, tighten the bolts alternately.
 - Before removing a unit, clean its surrounding area. Then after removal, cover it to prevent dust and other substances from getting in.
 - Before removing piping for hydraulic oil or coolant, or removing related parts, satisfactorily release internal pressure.
 - 2) Precautions for installation work
 - Tighten bolts and nuts (sleeve nuts) to the specified torque (screw tightening torque table).
 - When installing hoses, do not twist them or allow them to interfere with other parts.
 - Replace gaskets, O-rings, split cotter pins, and lock plates with new parts.
 - Properly bend split cotter pins and lock plates.
 - When applying an adhesive, first clean and remove oil/grease from the surfaces properly. Then apply two or three drops to the threaded areas.
 - When applying a liquid gasket, first clean and remove oil/grease from the application surface properly, and confirm that the surface is free of dust and damage. Then apply the product evenly.
 - Clean parts well. Repair scratches, dents, burrs, rust, etc.
 - Apply gear oil to rotating and sliding components.
 - Apply grease to the surfaces of press-fit parts.
 - After installing snap rings, confirm that they are properly seated in the grooves.
 - Connect wiring connectors securely after cleaning off adhering oil, dust and water.
 - Use lifting bolts that are not fatigued or deformed. Screw them in fully.
 - When tightening a split flange, tighten screws alternately to prevent uneven tightening.
 - Before installing hydraulic parts, confirm that they are free of damage and dust, etc.

3) Precautions when work is completed

- If coolant has been drained, securely retighten the drain cock and fill with coolant (mixing in long-life coolant) to the specified level. Start the engine and allow the coolant to circulate through the piping. Then add coolant again to the specified level.
- If hydraulic equipment has been removed and reinstalled, fill with hydraulic oil to the specified level. Start the engine and allow the oil to circulate through the piping. Then add oil again to the specified level.

2. REMOVAL AND INSTALLATION OF DRUMS

2-1. Removal of Drums

2-1-1. Front drum

- 1) Joint front frame and rear frame with lock pin.

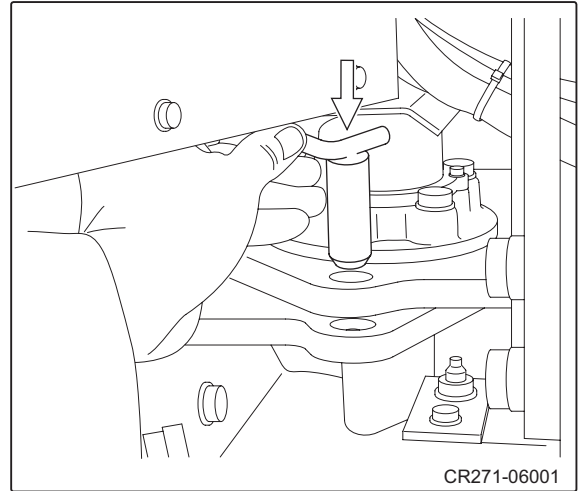

⚠ WARNING

The hydraulic oil in the machine is hot and compressed immediately after the machine is stopped. Disconnecting the hydraulic hoses in this condition can cause burns. Wait for the hydraulic oil to cool down before starting the work.

- 2) Disconnect hydraulic hose connecting to vibrator motor.

NOTE : Plug both ends of the disconnected hoses or implement other actions to prevent entry of foreign matter.

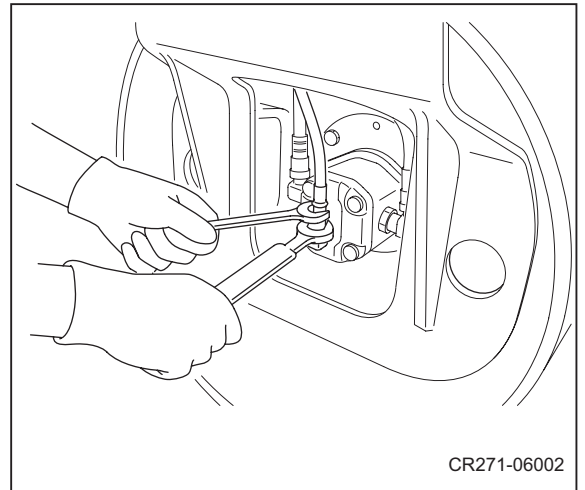

- 3) Disconnect hydraulic hose connecting to propulsion motor.

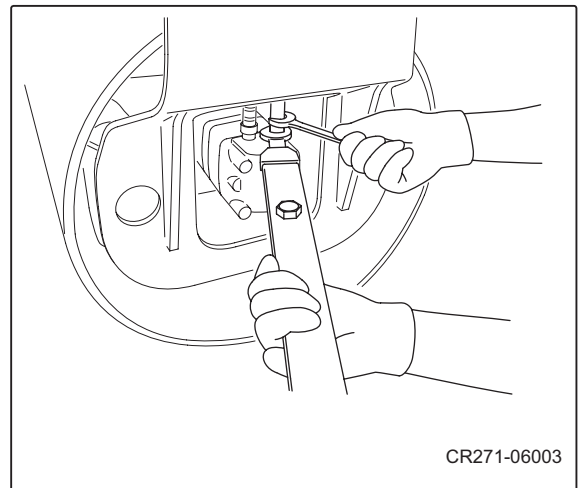

- 4) Flip up scraper blade.
- Loosen both side bracket fastening bolts.

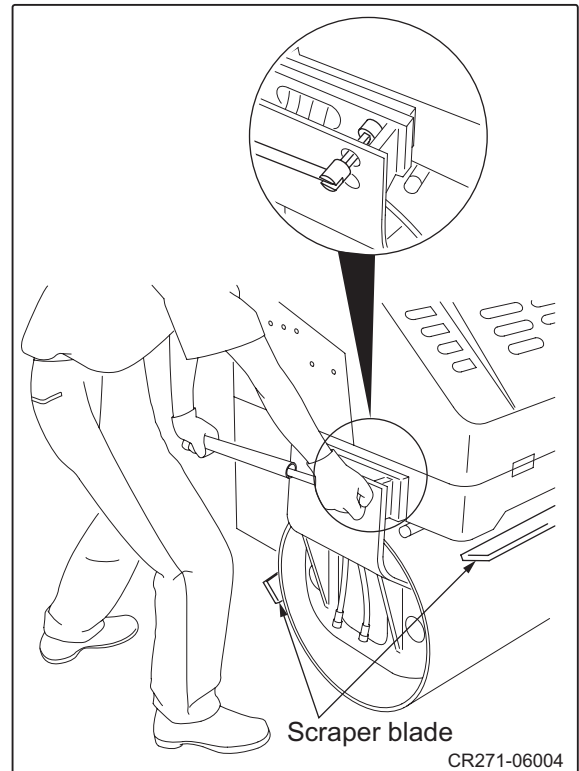

- 5) Lift frame with a crane.



Front axle : 650 kg (1,435 lbs.)

- Remove bolts.
- Remove side plate.

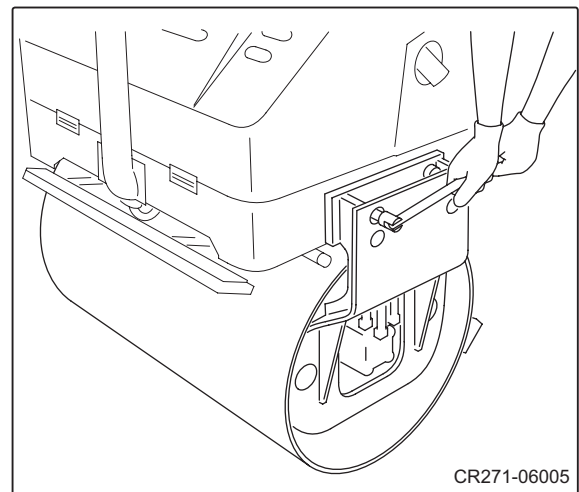

- 6) Flip up scraper blade.

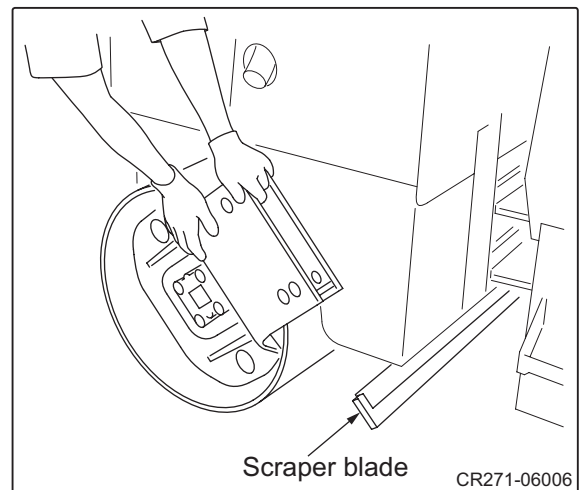

- 7) Remove drum assembly together with bracket from frame.

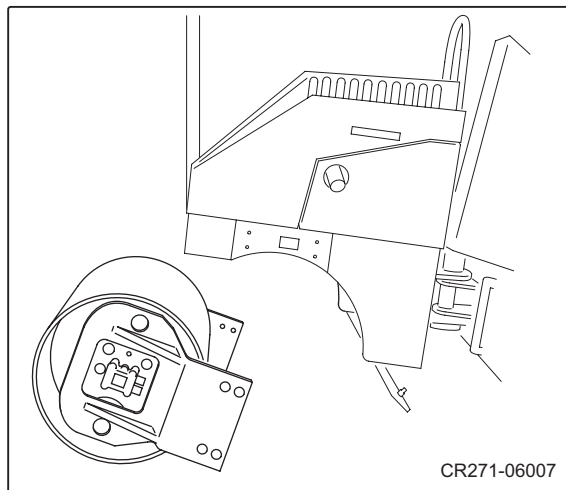

2-1-2. Rear drum

- 1) Remove bolts (1).
 - Remove cover (2).

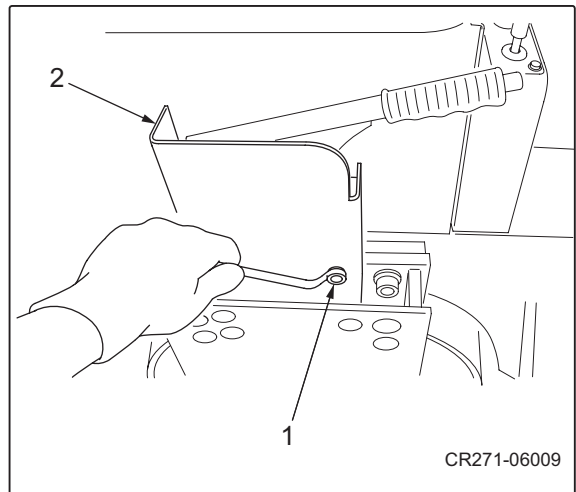

- 2) Remove clevis (3).

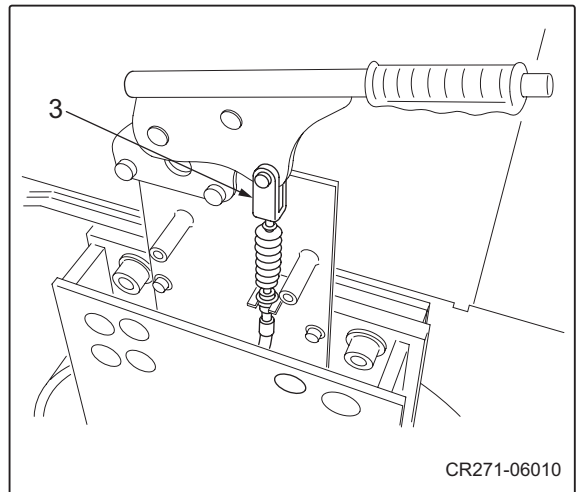

- 3) Remove parking brake cable (4).

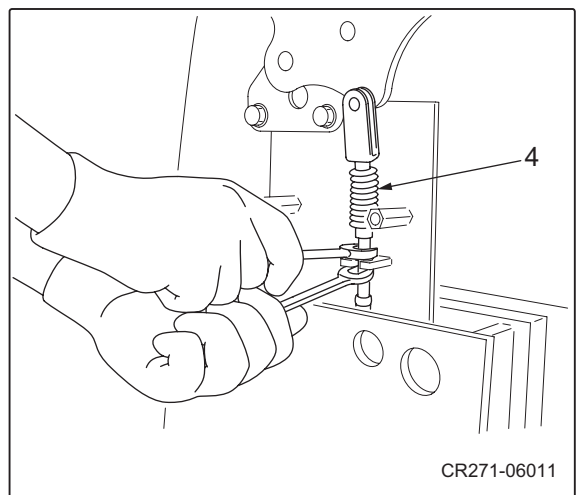

4) See step 5) and subsequent steps under “2-1-1.
Front drum”.



Rear axle : 680 kg (1,500 lbs.)

2-2. Installation of Drums

- 1) Install drum in reverse order in which it was removed.
 - Tightening torque for bolts where particular care is required when installing drum.



Bolt M16×50: 265 N·m (196 lbf·ft)
(Side bracket fastening bolts)

- 2) Upon installing vibratory drum, pay particular attention to items mentioned below.
 - Fill hydraulic oil tank to specified level to make for any oil leakage.
 - Start engine and circulate oil through piping. Then check oil level again, ensuring that the oil is at specified level.

NOTE : If the engine is run at high speed or the cylinder is operated to full stroke when the engine is started for the first time after the work is completed, the piston packing or other items may be damaged by air entering into the cylinder.

3. DRUM ASSEMBLY

3-1. Front Drum

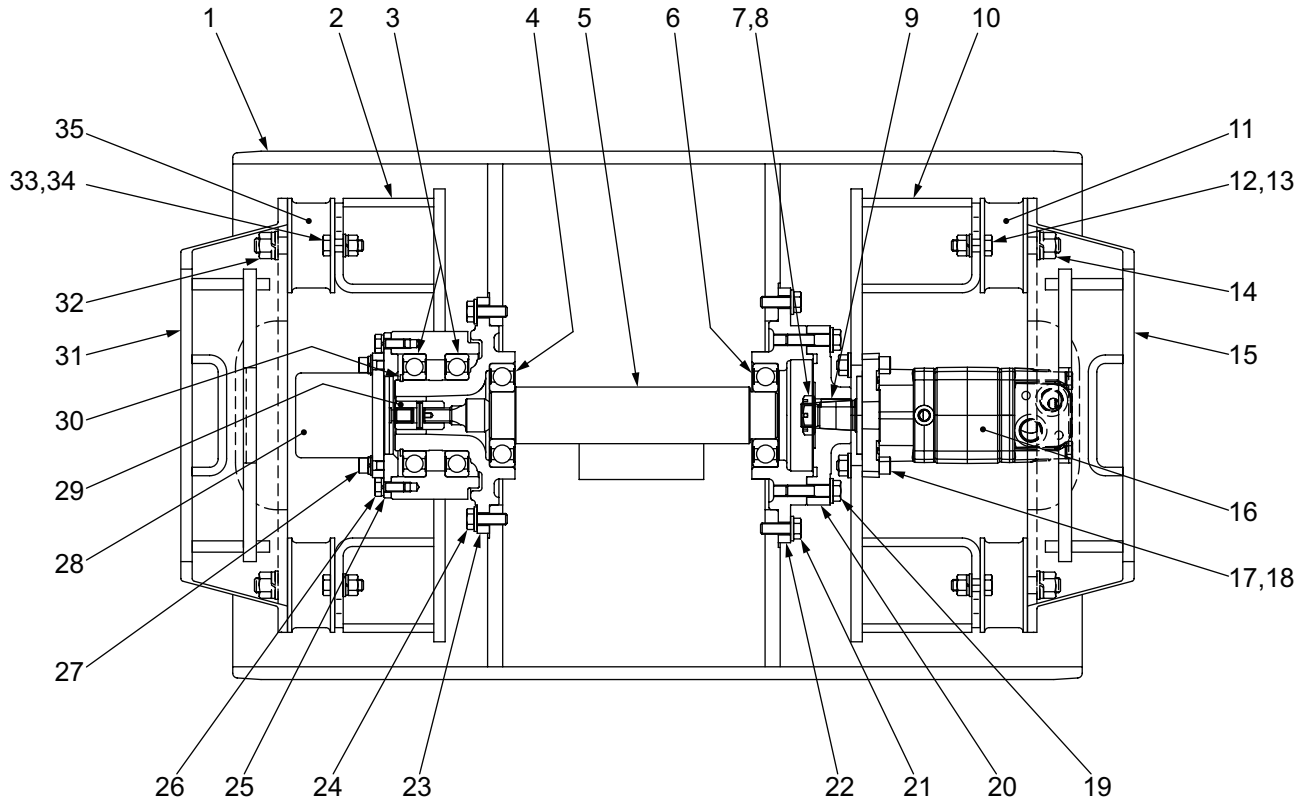

0563-43801-0 -10176-C

- | | | |
|----------------------|---------------------|----------|
| (1) Drum | (19) Bolt | : M12x50 |
| (2) Disc | (20) Flange | |
| (3) Ball bearing | (21) Bolt | : M12x35 |
| (4) Vibrator bearing | (22) Hub | |
| (5) Eccentric shaft | (23) Boss | |
| (6) Vibrator bearing | (24) Bolt | : M12x35 |
| (7) Castle nut | (25) Cover | |
| (8) Split pin | (26) Bolt | : M10x25 |
| (9) Sunk key | (27) Bolt | : M10x35 |
| (10) Disc | (28) Vibrator motor | |
| (11) Damper | (29) Coupling | |
| (12) Bolt | (30) Retaining ring | |
| (13) Nut | (31) Bracket | |
| (14) Nut | (32) Nut | : M16 |
| (15) Bracket | (33) Bolt | : M12x35 |
| (16) Propulsor motor | (34) Nut | : M12 |
| (17) Bolt | (35) Damper | |
| (18) Nut | | |

3-2. Rear Drum

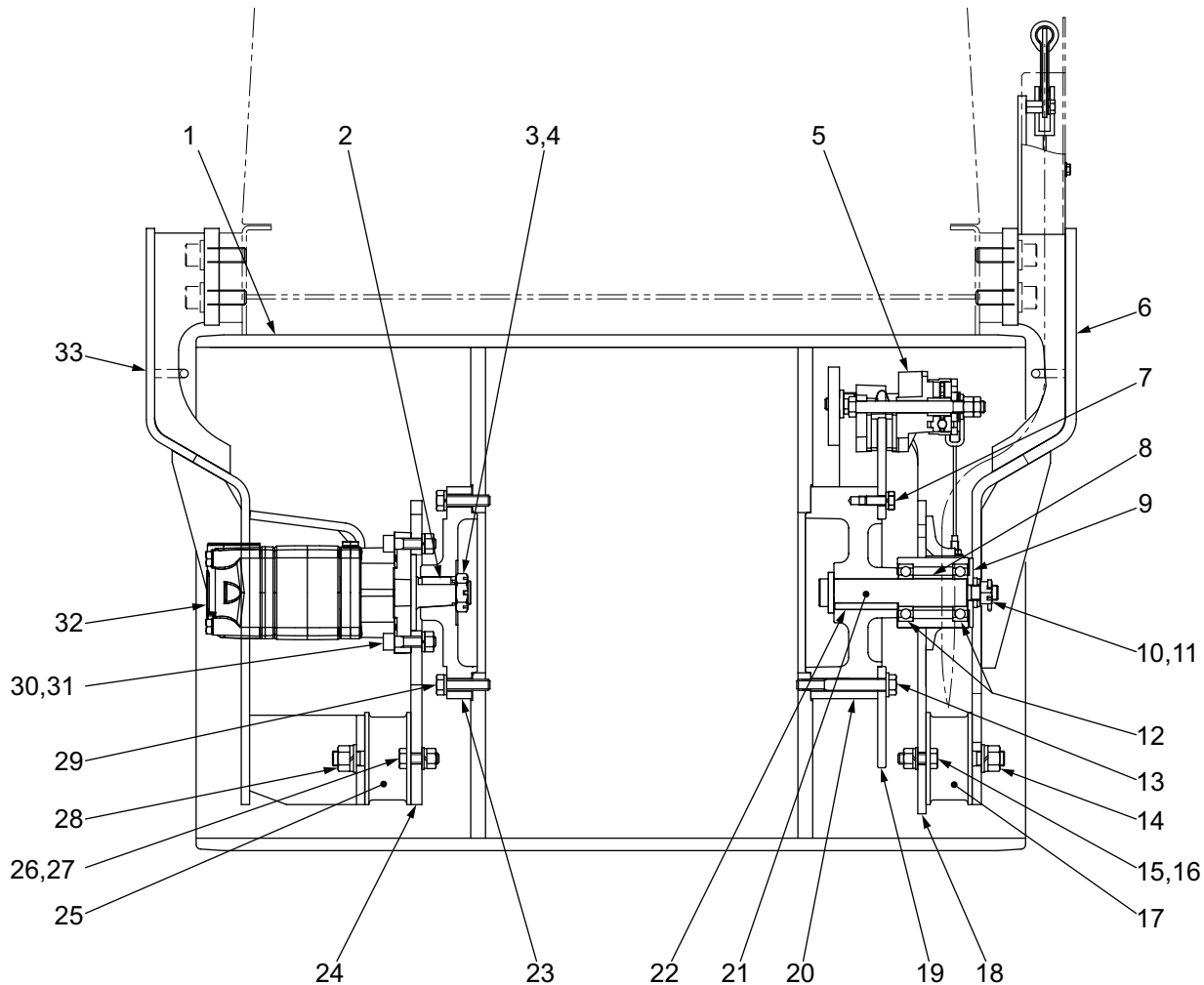

0563-27803-0 -10289-0

- | | |
|---------------------------|----------------------|
| (1) Drum | (18) Side plate |
| (2) Sunk key | (19) Disc plate |
| (3) Castle nut : 1"-20UNF | (20) Flange |
| (4) Split pin | (21) Shaft |
| (5) Brake ASSY | (22) Key |
| (6) Bracket | (23) Flange |
| (7) Bolt : M10x25 | (24) Side plate |
| (8) Spacer | (25) Damper |
| (9) Washer | (26) Bolt : M12x35 |
| (10) Castle nut : M16 | (27) Nut : M12 |
| (11) Split pin | (28) Nut : M16 |
| (12) Ball bearing | (29) Bolt : M12x45 |
| (13) Bolt : M12x100 | (30) Bolt : M12x45 |
| (14) Nut : M16 | (31) Nut : M12 |
| (15) Bolt : M12x35 | (32) Propulsor motor |
| (16) Nut : M12 | (33) Bracket |
| (17) Damper | |

4. DISASSEMBLY AND REASSEMBLY OF DRUMS

4-1. Disassembly of Drums

- Lead line numbers shown in the illustrations for the following drum disassembly and reassembly procedures are constant with part numbers of drum assembly shown on page 6-008, 6-009.

4-1-1. Front drum

- 1) Remove nuts (14), (32).
 - Remove bracket (15), (31).

 (15), (31) Bracket : 25 kg (55 lbs.)

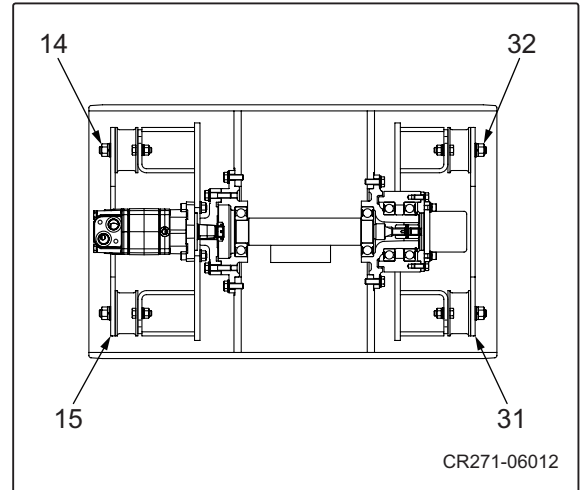

WARNING

- When standing the vibratory drum, use wooden blocks of sufficient strength to securely support the drum.
- Carry out the work in an unstrained posture using a work stool or the like.

- 2) Stand vibratory drum ASSY with its vibrator motor (28) side facing up.

 Vibratory drum ASSY : 330 kg (728 lbs.)

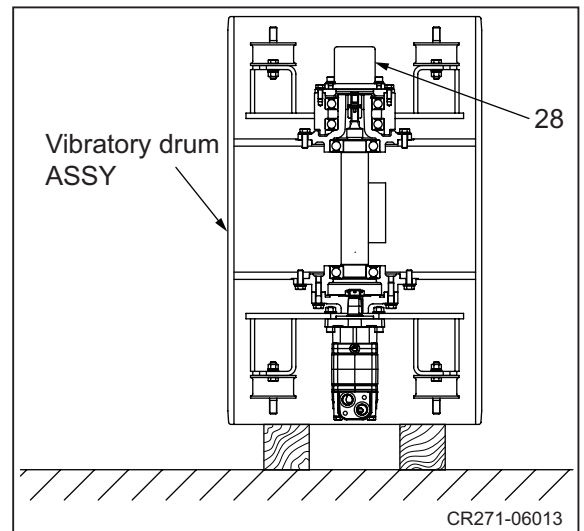

- 3) Remove bolts (27).
 - Remove vibrator motor (28).

 (28) Vibrator motor : 3 kg (7 lbs.)

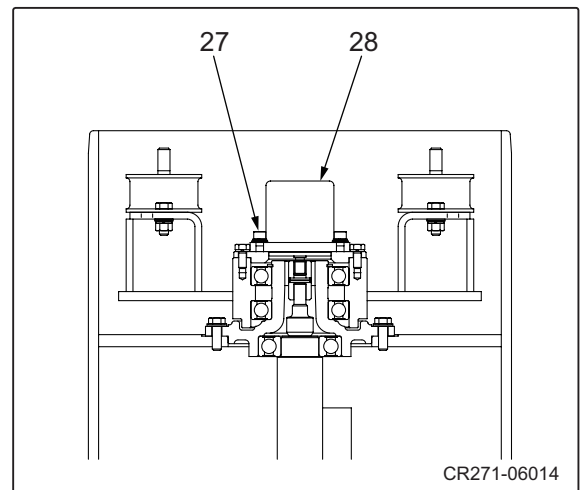

DRUMS

4) Remove coupling (29).

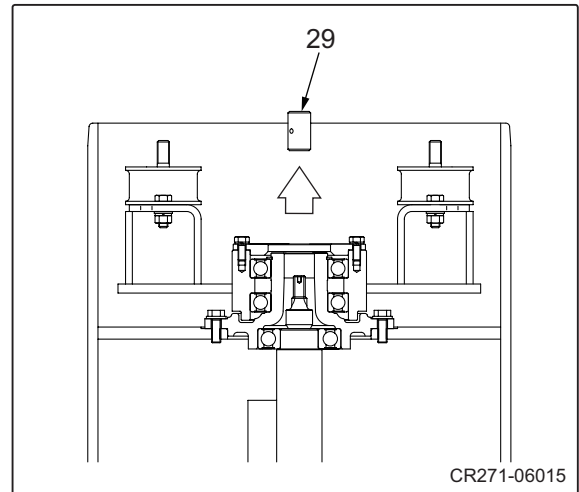

5) Remove bolts (24).

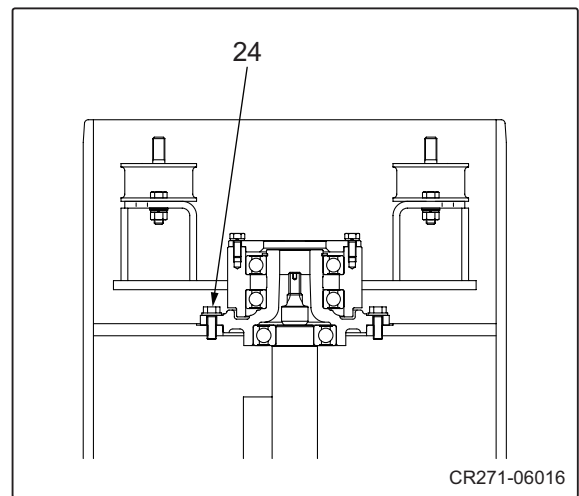

• Remove eight bolts (24).

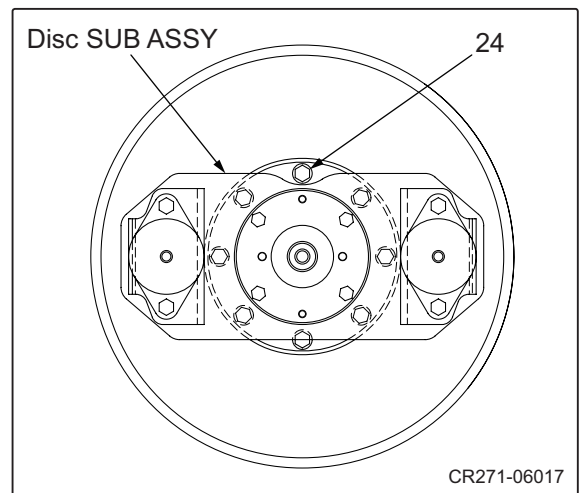

6) Remove disc SUB ASSY.

 Disc SUB ASSY : 40 kg (88 lbs.)

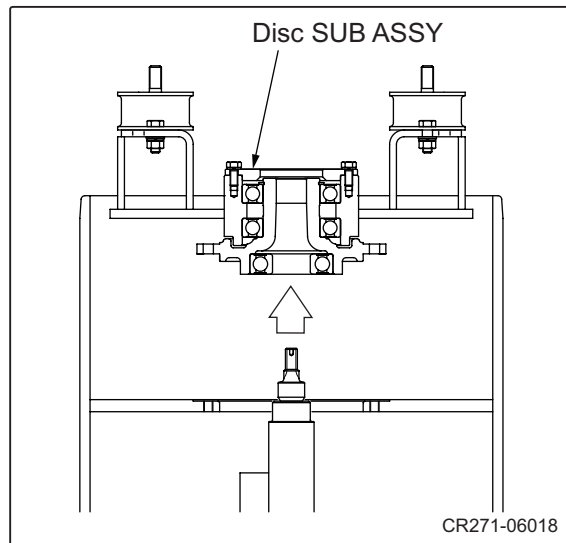

7) Remove eccentric shaft (5).

 (5) Eccentric shaft : 10 kg (22 lbs.)

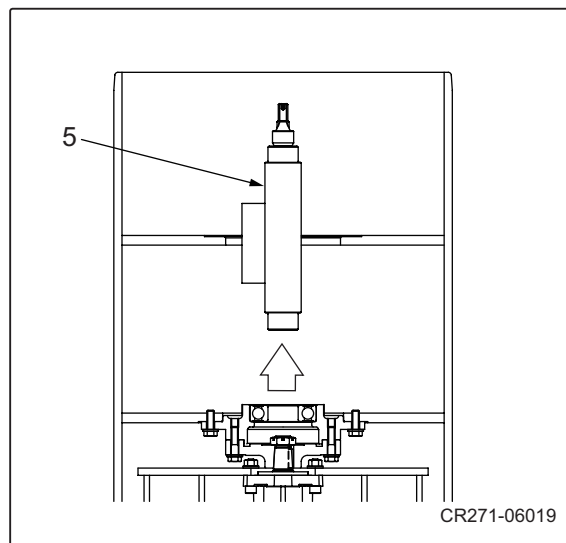

⚠ WARNING

Be careful because reversing the vibratory drum involves Risk. Confirm that the surrounding area is safe, and work in a natural, unstained posture.

8) Lift drum with a crane and reverse it.

 Drum SUB ASSY : 275 kg (606 lbs.)

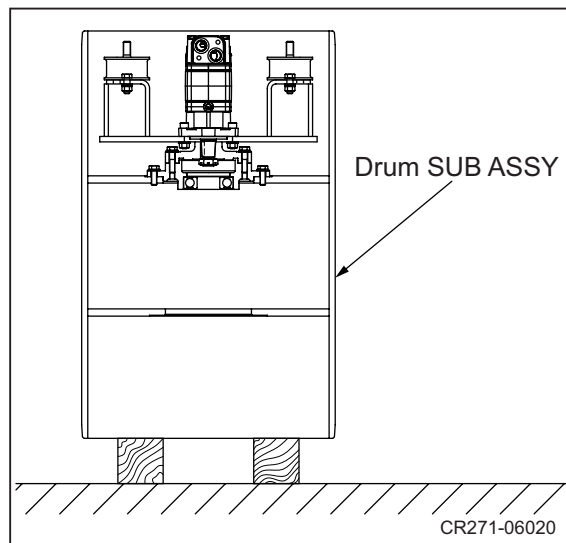

9) Remove bolts (19).

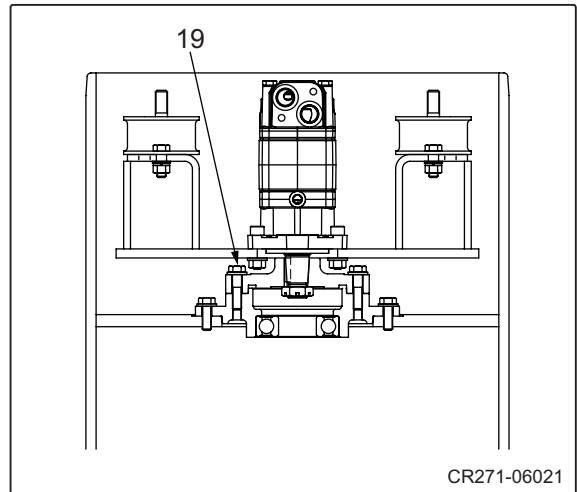

- Remove four bolts (19).

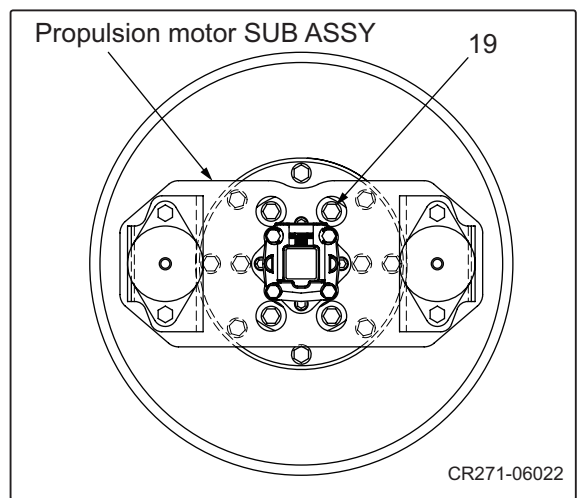

- Remove two bolts (19).

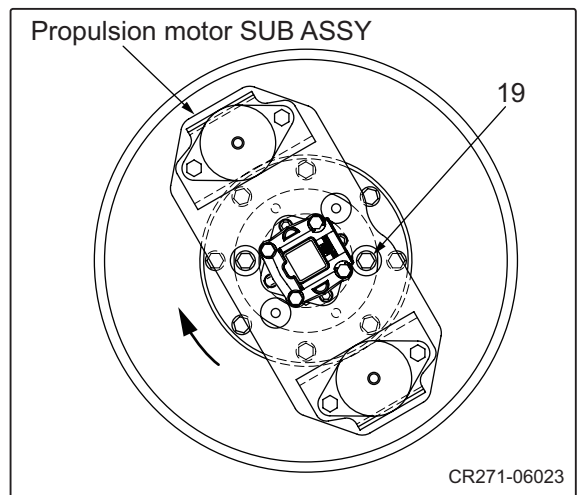

10) Remove propulsion motor SUB ASSY.



Propulsion motor SUB ASSY : 40 kg (88 lbs.)

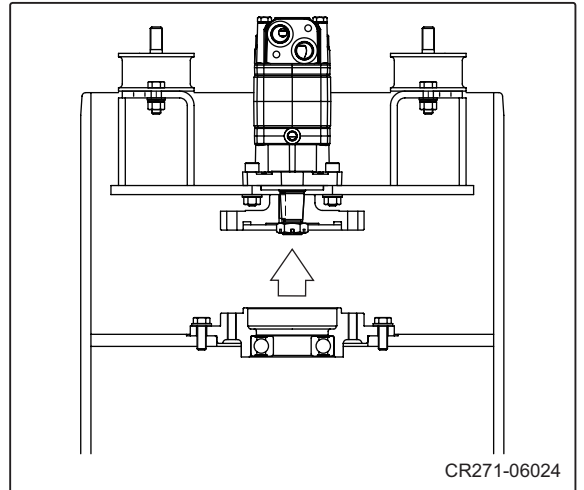

11) Remove bolts (21).

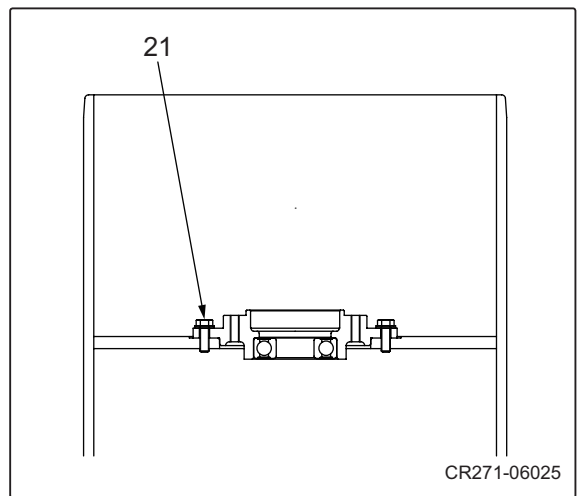

12) Remove hub (22).



(22) Hub : 10 kg (22 lbs.)

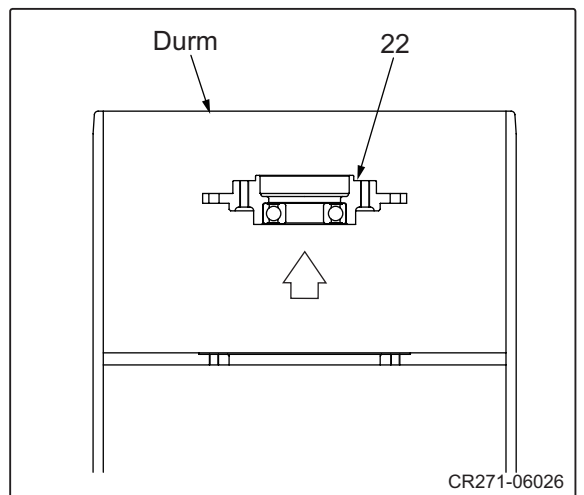

13) Disassembly of disc SUB ASSY.

- Remove bolt (26).
- Remove cover (25).

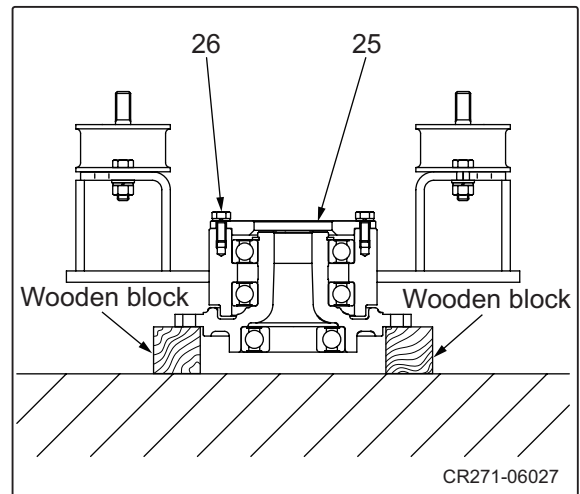

14) Remove retaining ring (30).

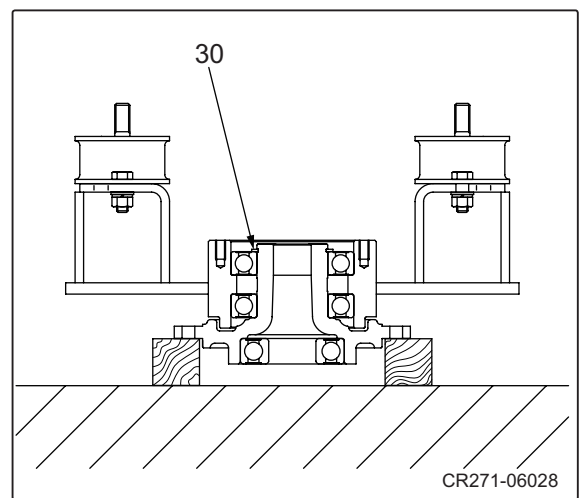

15) Put a piece of steel plate on end of boss (23).

- Set a puller on disc (2).
- Remove disc SUB ASSY with bearing (3) from boss (23).



Disc SUB ASSY : 25 kg (55 lbs.)

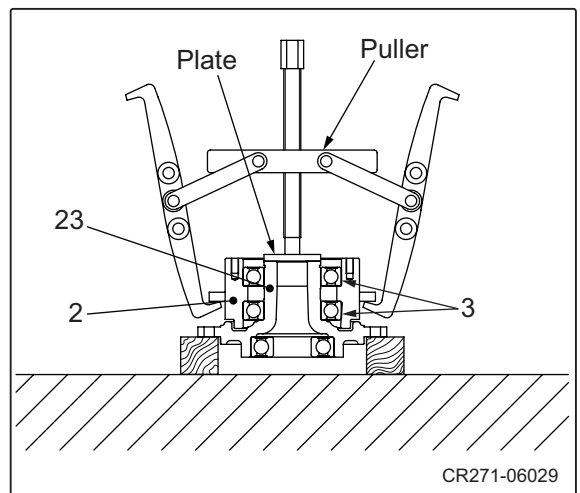

16) Disassembly of propulsion motor SUB ASSY.

(Remove propulsion motor)

- Remove split pin (8).
- Remove castle nut (7).
- Remove flange (20).



(20) Flange : 5 kg (11 lbs.)

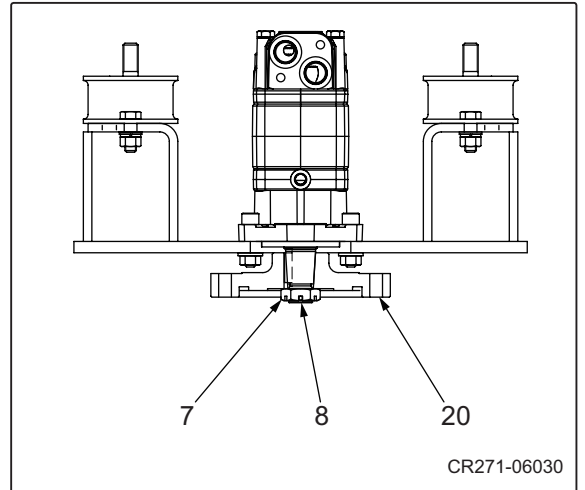

17) Remove bolt (17), nut (18).

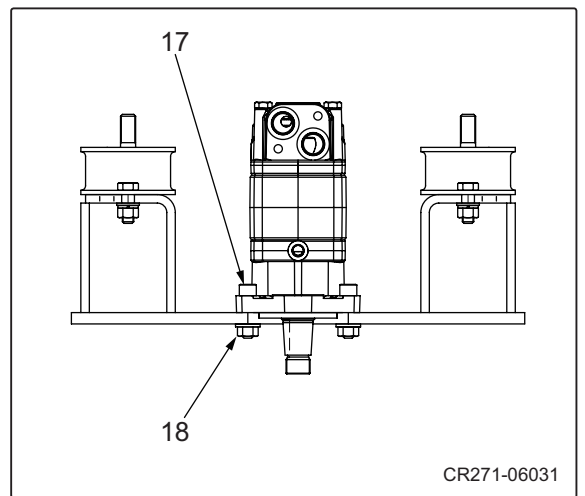

18) Remove propulsion motor (16).



(16) Propulsion motor : 15 kg (33 lbs.)

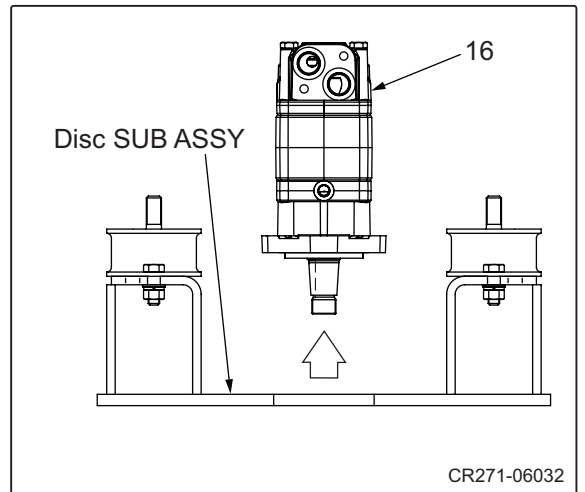

4-1-2. Rear drum

- 1) Remove nuts (14), (28).
 - Remove bracket (6), (33).

 (6) Bracket : 20 kg (44 lbs.)

(33) Bracket: 30 kg (66 lbs.)

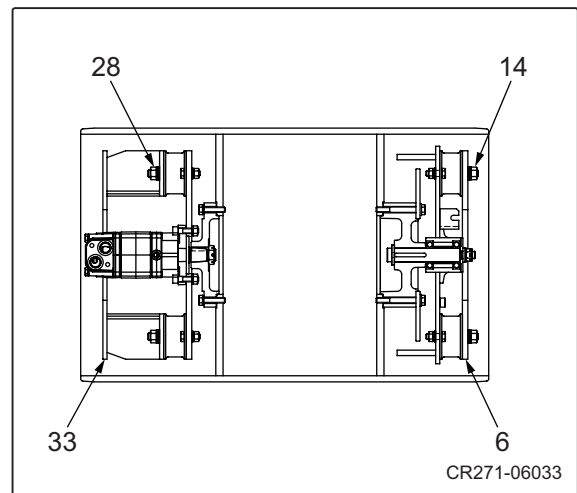

WARNING

- When standing the vibratory drum, use wooden blocks of sufficient strength to securely support the drum.
- Carry out the work in an unstrained posture using a work stool or the like.

- 2) Stand drum ASSY with its disc brake side facing up

 Vibratory drum ASSY : 310 kg (683 lbs.)

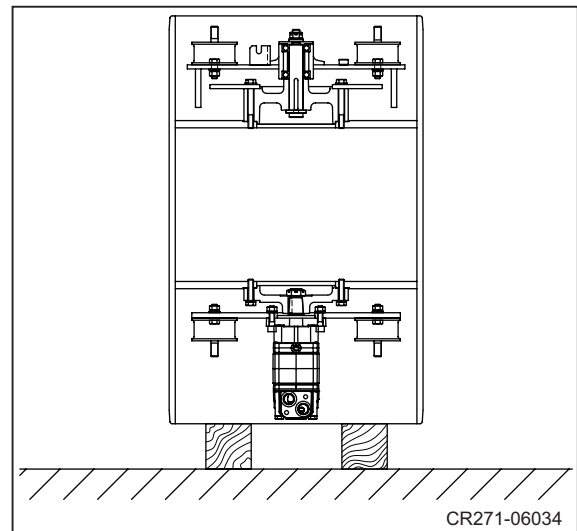

- 3) Remove bolts (13).

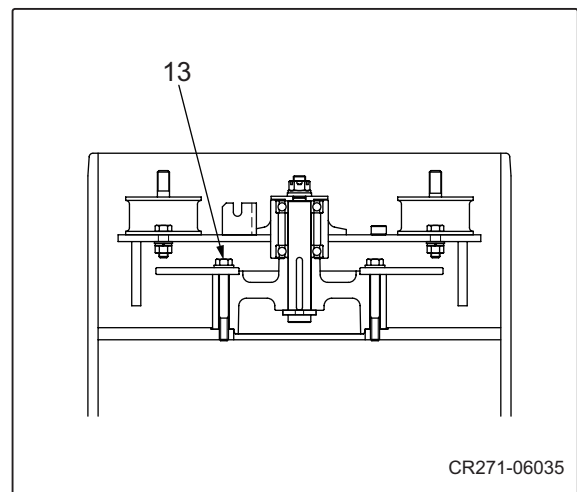

- Remove six bolts (13).

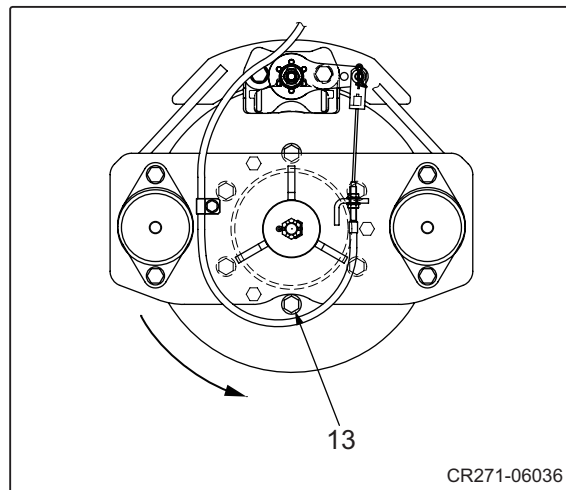

- 4) Remove disc brake SUB ASSY.



Disc brake SUB ASSY : 50 kg (110 lbs.)

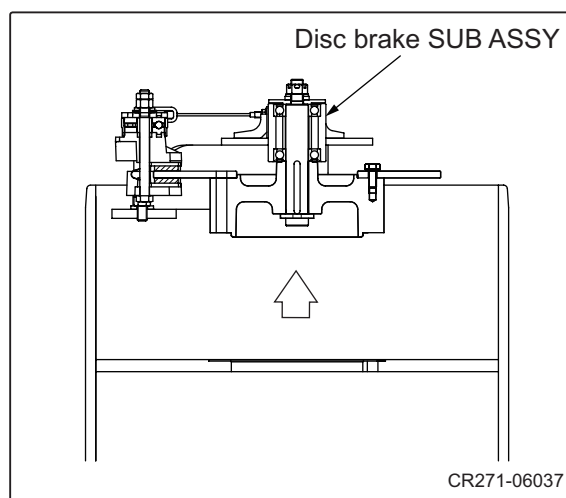

⚠ WARNING

Be careful because reversing the drum involves Risk. Confirm that the surrounding area is safe, and work in a natural, unstained posture.

- 5) Reverse drum SUB ASSY.



Drum SUB ASSY : 260 kg (573 lbs.)

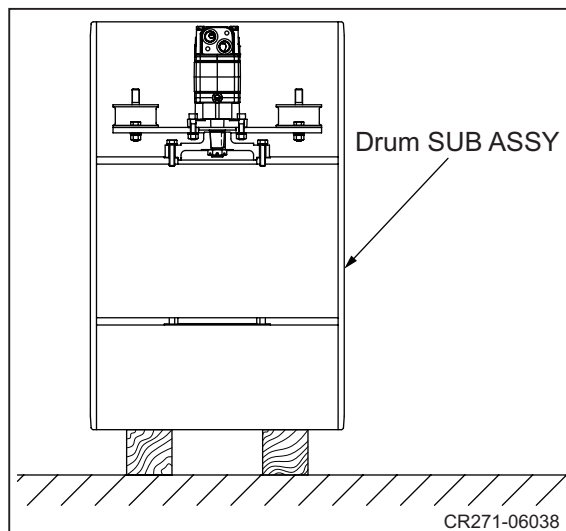

DRUMS

6) Remove bolts (29).

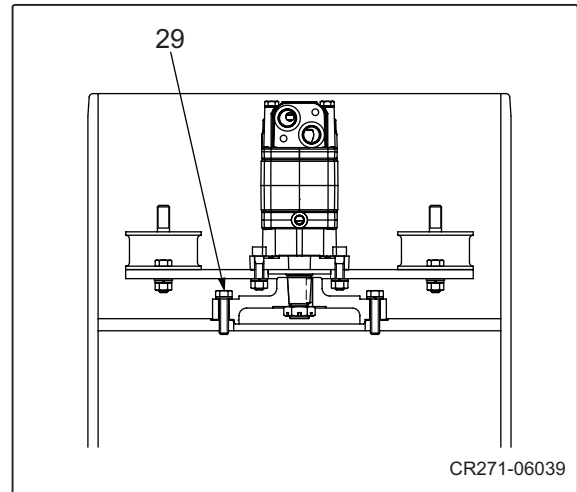

• Remove four bolts (29).

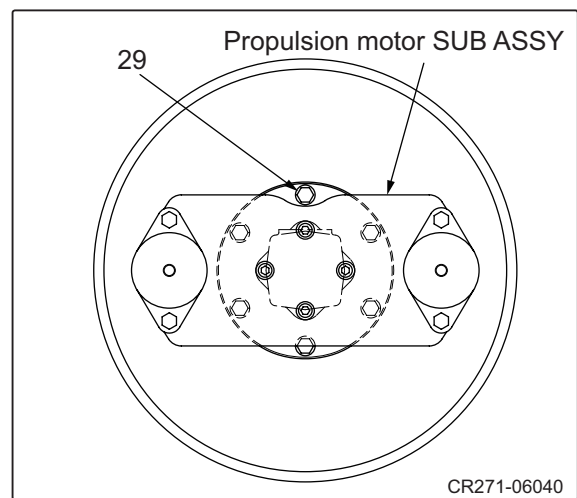

7) Remove propulsion motor SUB ASSY.

 Propulsion motor SUB ASSY : 35 kg (77 lbs.)

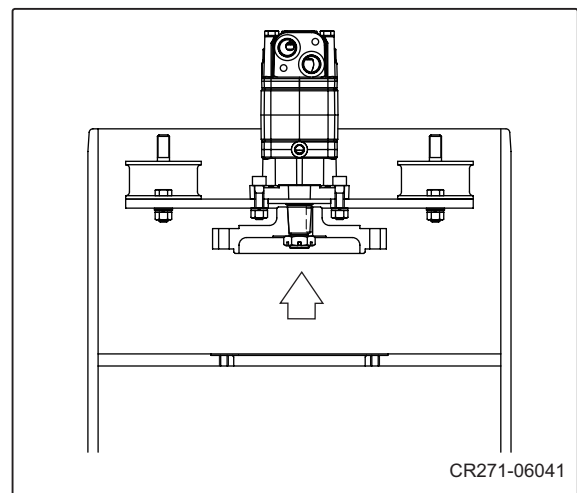

- 8) Remove split pin (4).
- Remove castle nut (3).
 - Remove flange (23).

 (23) Flange : 10 kg (22 lbs.)

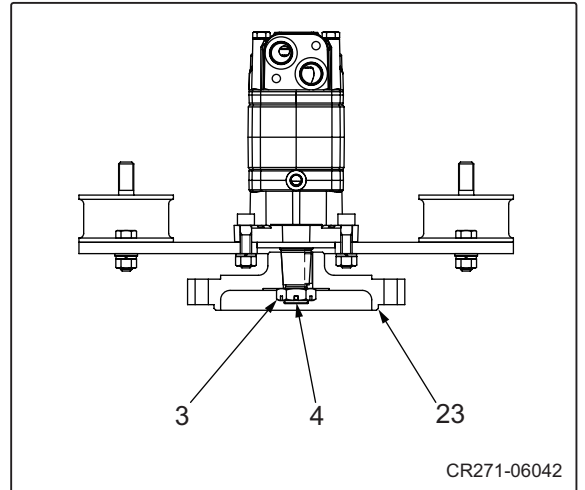

- 9) Remove bolt (30), nut (31).

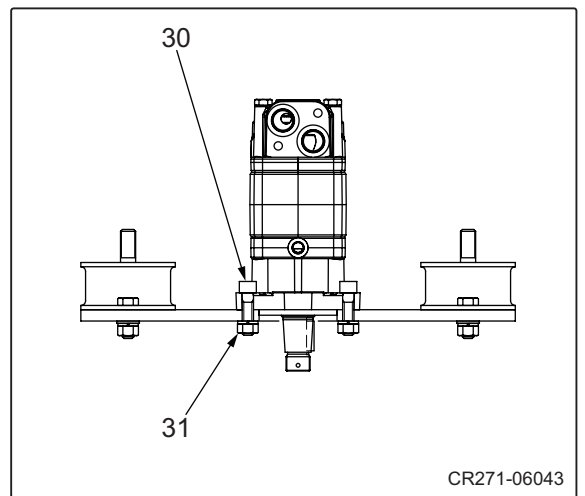

- 10) Remove propulsion motor (32).

 (32) Propulsion motor : 15 kg (33 lbs.)

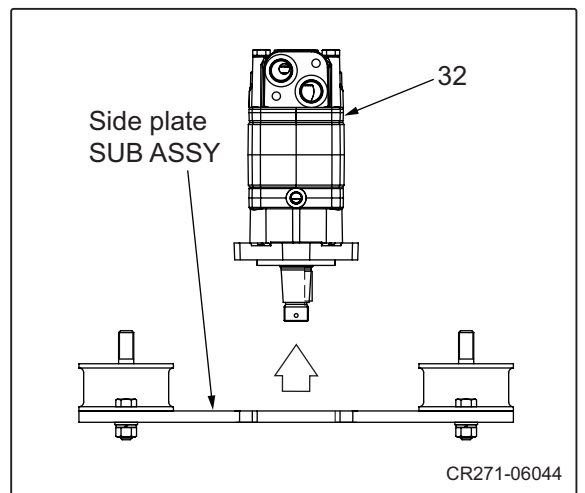

11) Remove bolt (7).

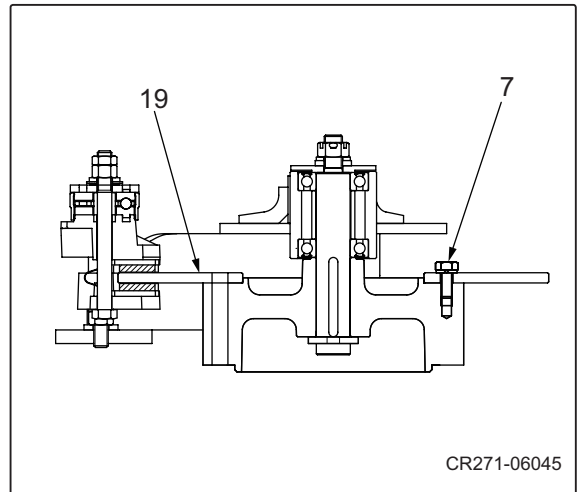

- Remove three bolts (7).

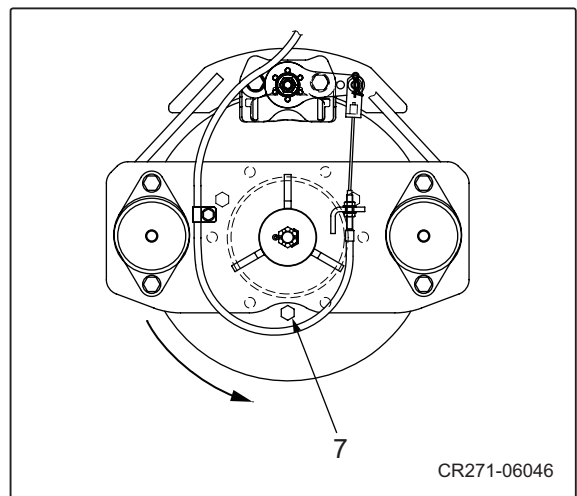

12) Remove split pin (11).

- Remove castle nut (10).
- Remove washer (9).

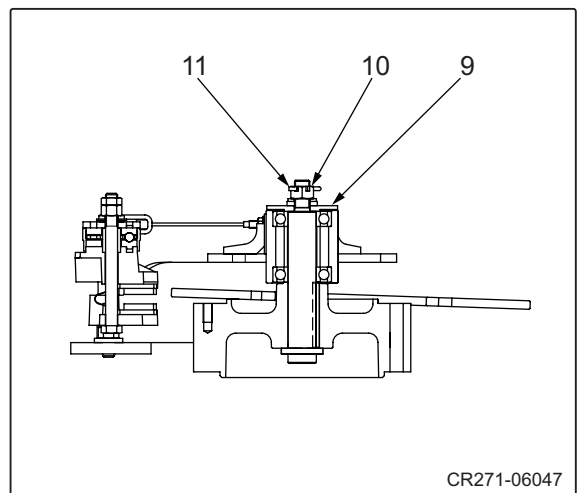

13) Remove side plate SUB ASSY.



Side plate SUB ASSY : 20 kg (44 lbs.)

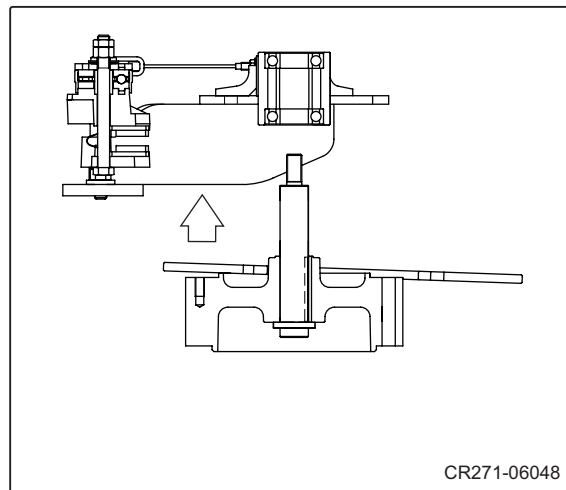

4-2. Reassembly of Drums

4-2-1. Front drum

- Before reassembling, clean disassembled parts well and check that there is no abnormality.

⚠ WARNING

- When standing the vibratory drum, use wooden blocks of sufficient strength to securely support the drum.
- Carry out the work in an unstrained posture using a work stool or the like.

- 1) Stand drum (1) with its propulsion motor side facing up.



Drum : 225 kg (496 lbs.)

NOTE : Propulsion motor side dimension “a” : 320m (12.5 in.).

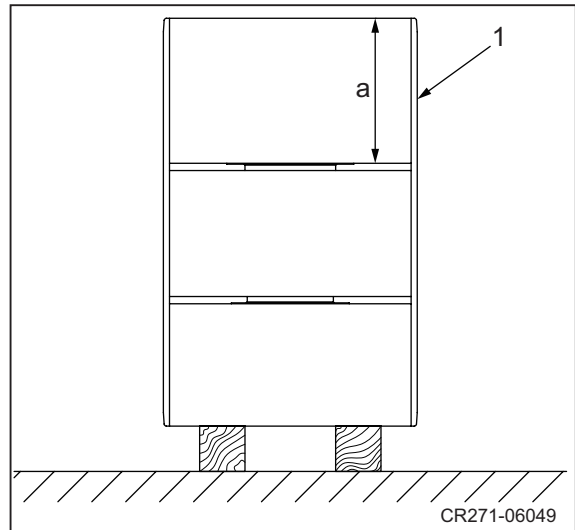

- 2) Apply a coat of gear oil to hub (22) at where bearing will be press-fitted.
 - Drive in vibrator bearing (6).

NOTE : Take care not to damage the bearing when installing it.

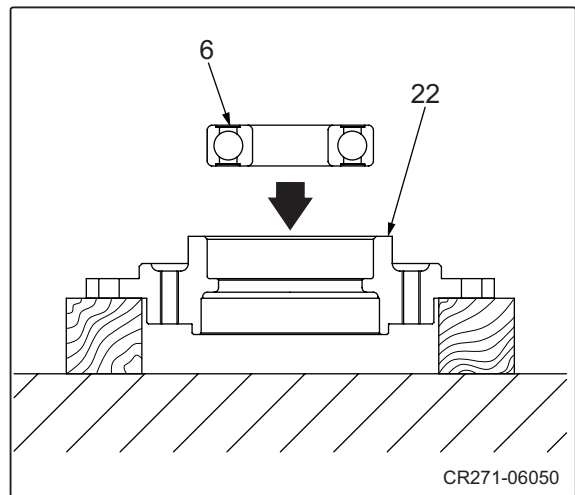

- 3) Reverse hub SUB ASSY and lower hub SUB ASSY on mounting surface of drum (1)..



Hub SUB ASSY : 10 kg (22 lbs.)

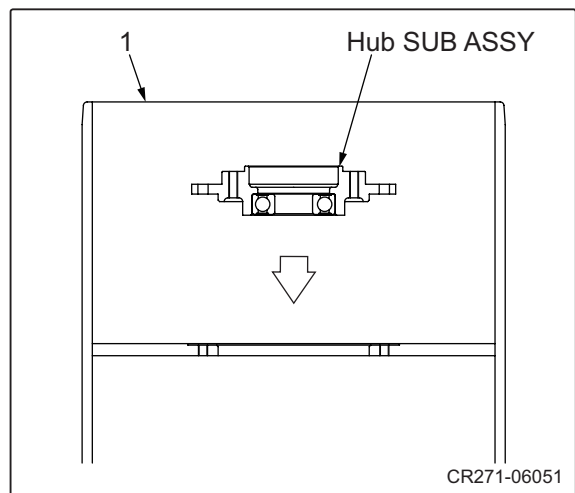

4) Secure hub SUB ASSY with eight bolts (21) and washers.

 (21) Bolt : 108 N·m (80 lbf·ft)

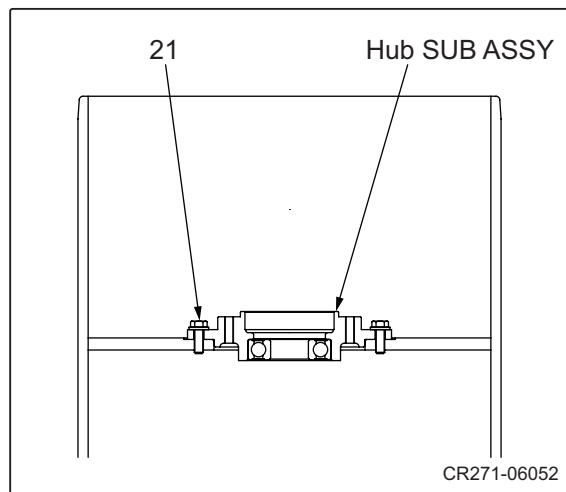

5) Install propulsion motor (16) to disc SUB ASSY.

 (16) Propulsion motor : 15 kg (33 lbs.)

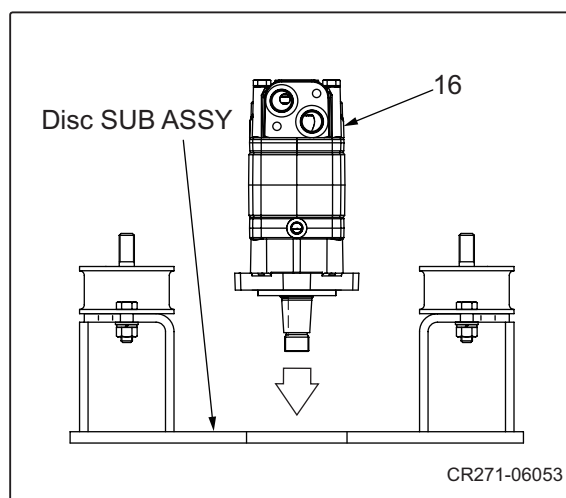

6) Secure propulsion motor (16) with fore bolts (17) nut (18) and washers.

 (18) Nut : 108 N·m (80 lbf·ft)

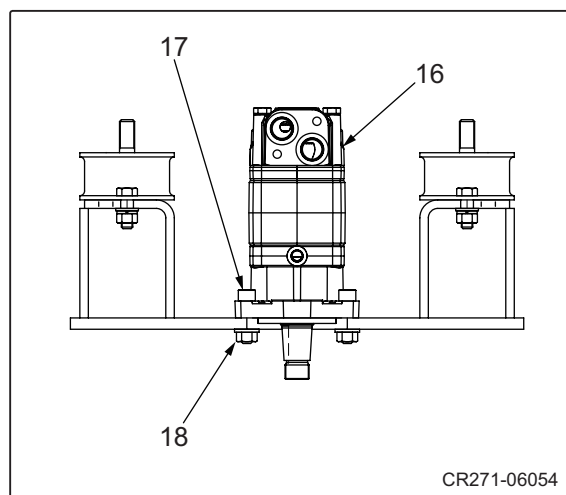

DRUMS

- 7) Install sunk key (9).
• Install flange (20).

 Flange : 5 kg (11 lbs.)

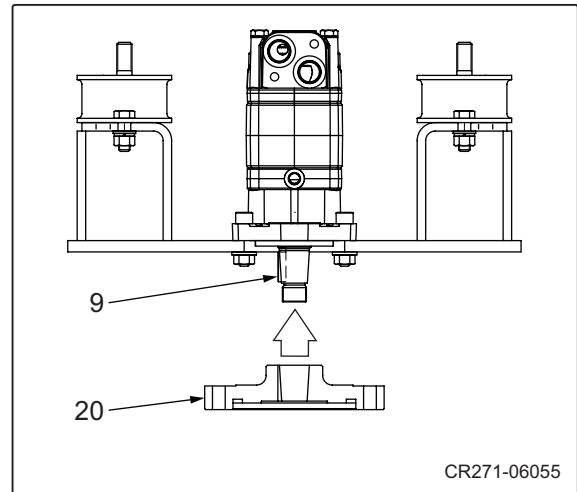

- 8) Secure flange (20) with castle nut (7).

 (7) Nut : 200 N·m (147.5 lbf·ft)

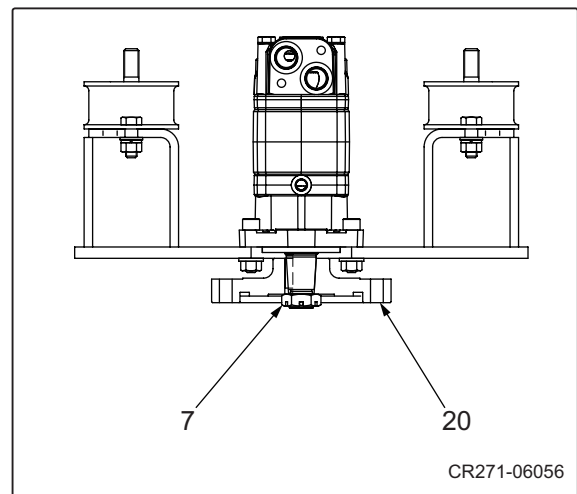

- Install split pin (8).

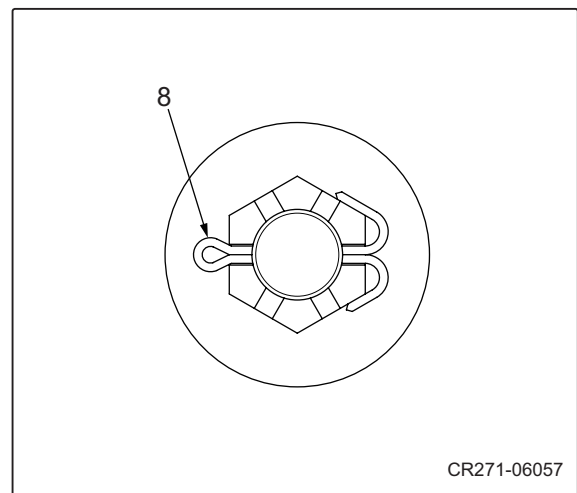

9) Lower propulsion motor SUB ASSY on mounting surface of hub.

 Propulsion motor SUB ASSY : 40 kg (88 lbs.)

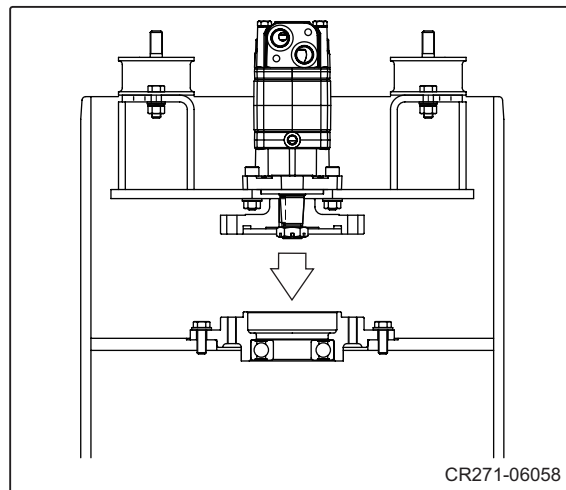

10) Secure propulsion motor SUB ASSY with bolts (19) and washers.

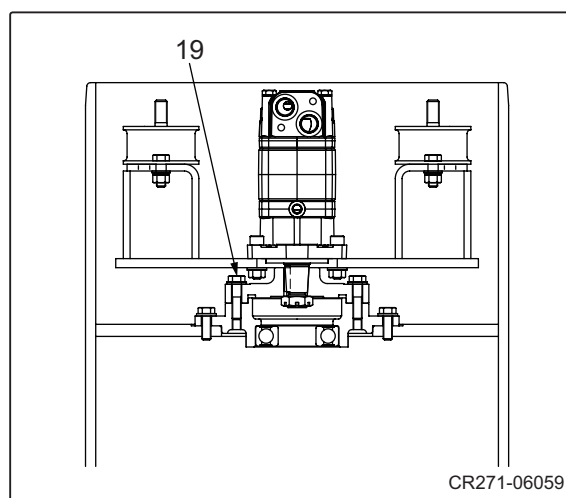

- Secure propulsion motor SUB ASSY with four bolts (19) and washers.

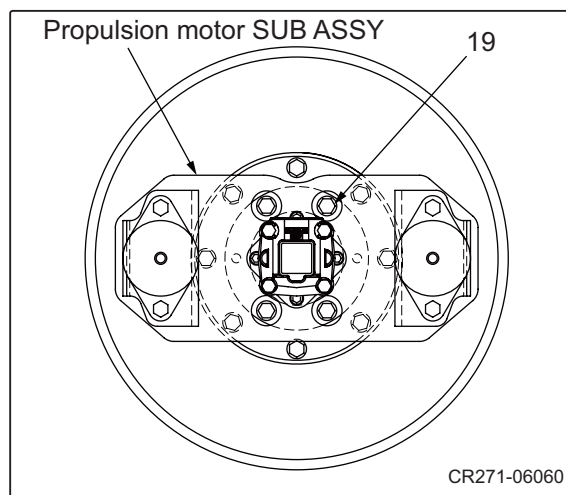

- Secure propulsion motor SUB ASSY with two bolts (19) and washers.

 (19) Bolt : 108 N·m (80 lbf·ft)

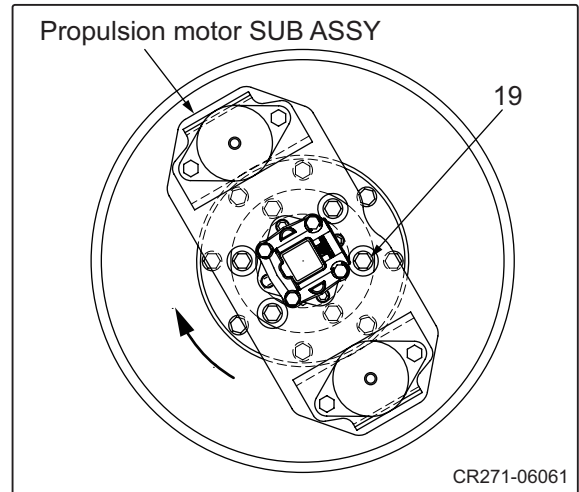

WARNING

Be careful because reversing the vibratory drum involves Risk. Confirm that the surrounding area is safe, and work in a natural, unstained posture.

- 11) Reverse drum SUB ASSY.

 Drum SUB ASSY : 275 kg (606 lbs.)

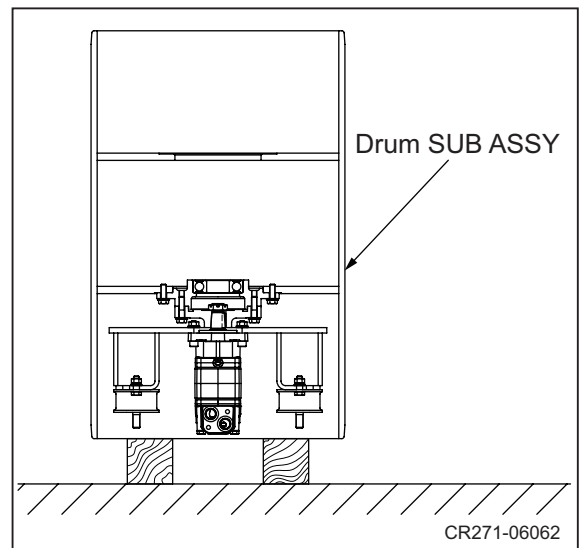

- 12) Install eccentric shaft (5).

 Eccentric shaft : 10 kg (22 lbs.)

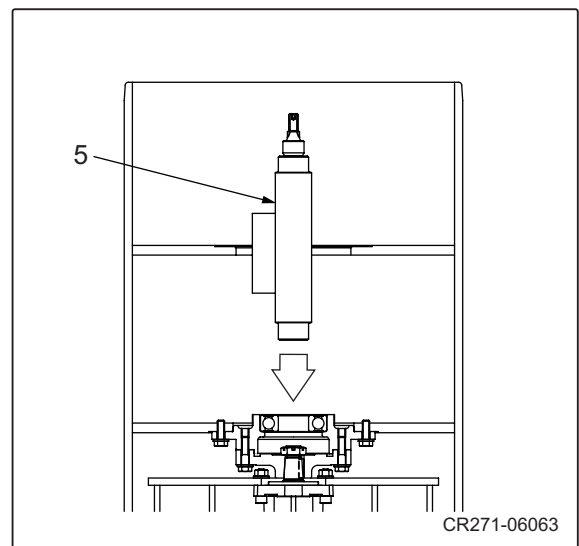

13) Apply a coat of gear oil to boss (23) at where bearing will be press-fitted.

- Drive in vibrator bearing (4).

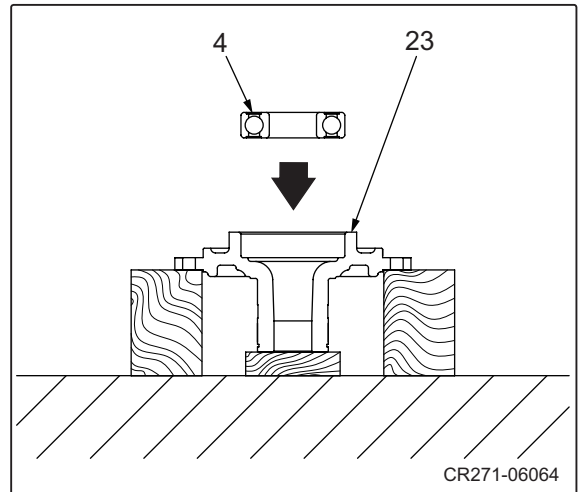

14) Apply a coat of gear oil to disc SUB ASSY at where bearing will be press-fitted.

- Drive in bearing (3).

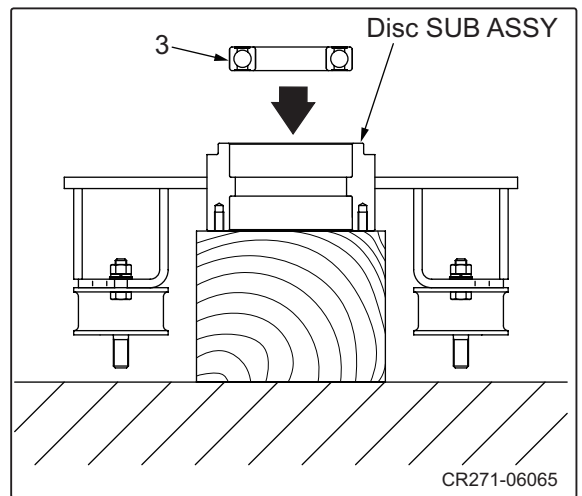

15) Reverse disc SUB ASSY.



Drum SUB ASSY : 25 kg (55 lbs.)

- Apply a coat of gear oil to disc SUB ASSY at where bearing will be press-fitted.
- Drive in bearing (3).

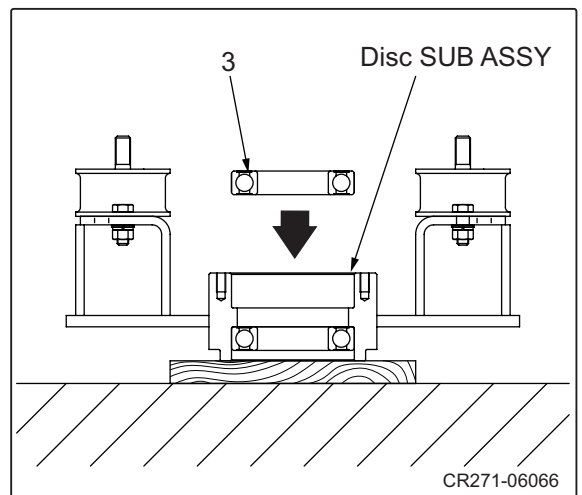

16) Apply a coat of gear oil to boss (23) at where bearing will be press-fitted.

- Lower disc SUB ASSY to boss SUB ASSY.



Disc SUB ASSY : 30 kg (66 lbs.)

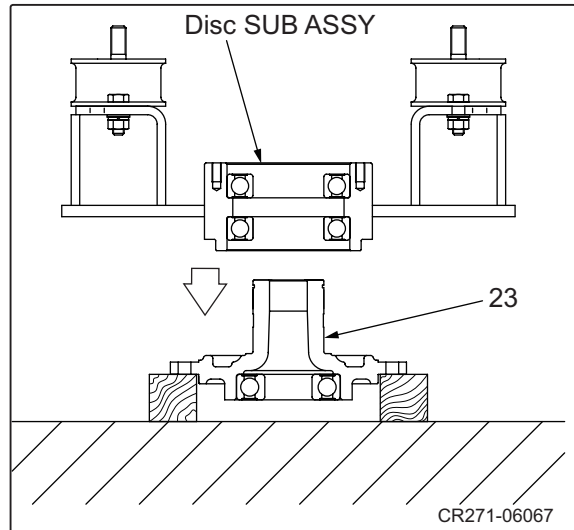

17) Install retaining ring (30).

NOTE : Make sure that the retaining ring is fitted completely in its groove.

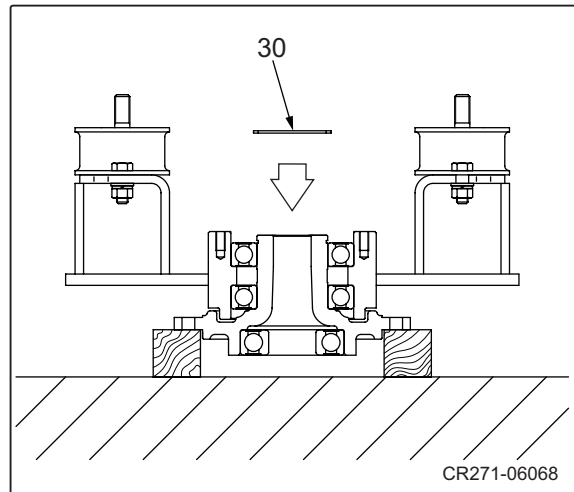

18) Install cover hub (25).

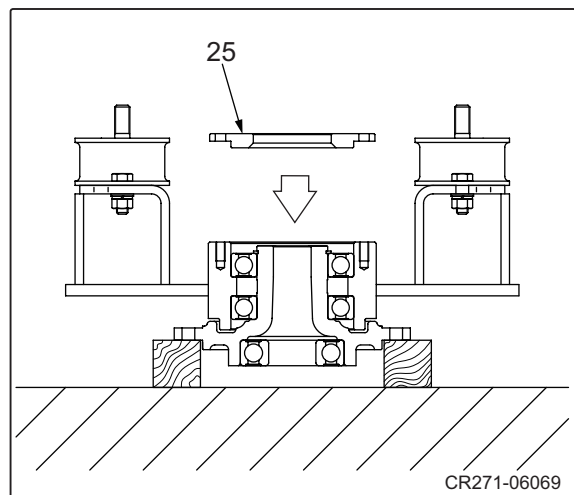

19) Secure cover hub (25) to disc SUB ASSY with four bolts (26) and spring washers.

 (26) Bolt : 59 N·m (44 lbf·ft)

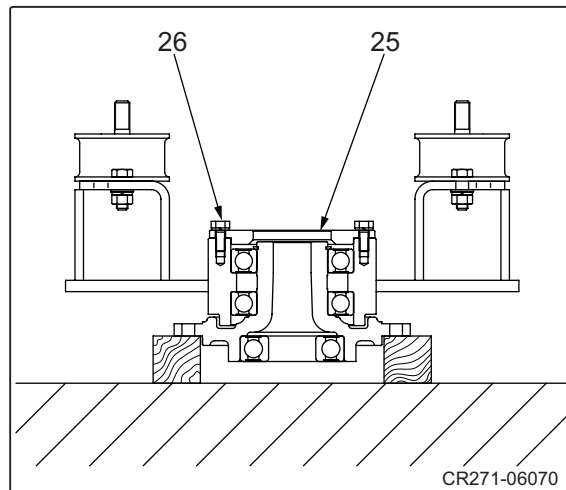

20) Lower disc SUB ASSY on mounting surface of vibratory drum slowly.

 Disc SUB ASSY : 40 kg (88 lbs.)

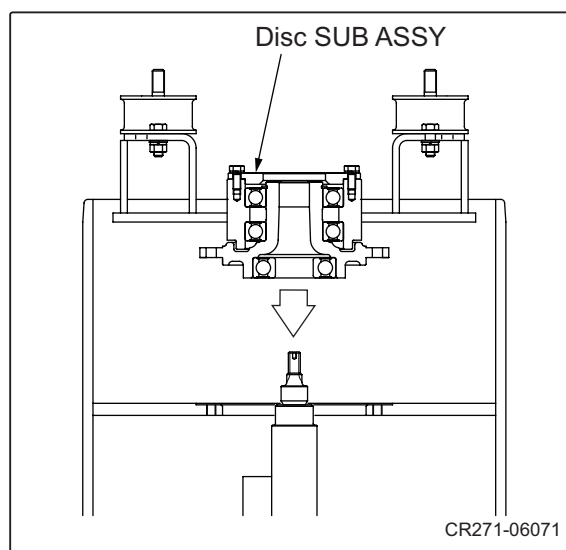

21) Secure disc SUB ASSY with bolts (24) and washers.

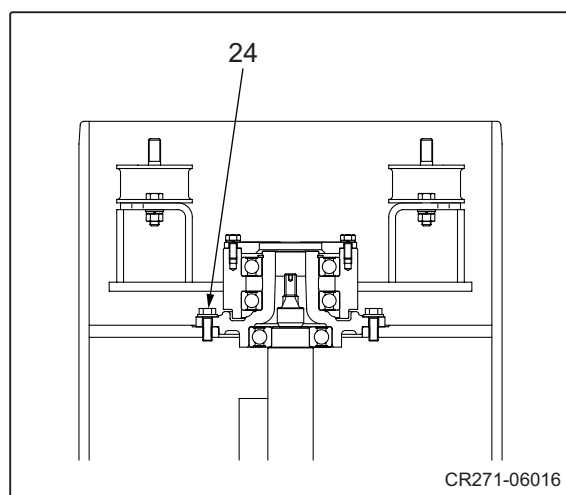

DRUMS

- Secure disc SUB ASSY with eight bolts (24) and washers.

 (24) Bolt : 108 N·m (80 lbf·ft)

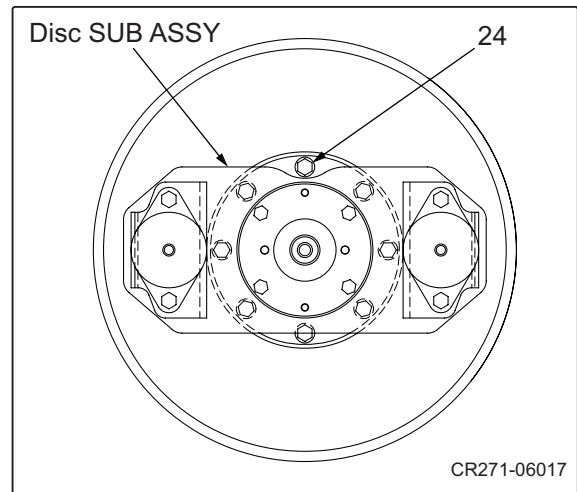

- 22) Drive spring pin into coupling (29).

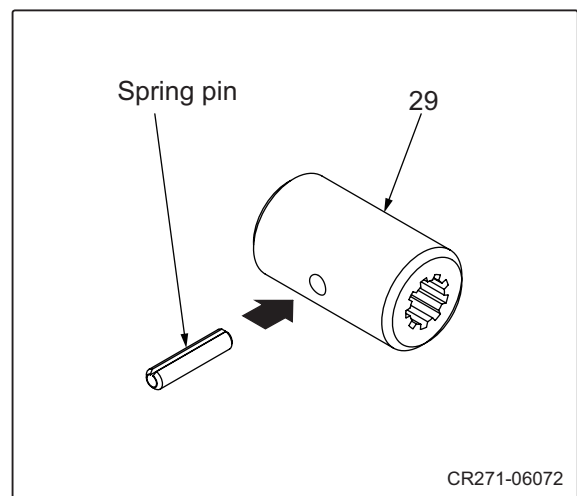

- 23) Apply molybdenum-based grease to splined portion of coupling (29).

- Fit coupling (29) to splined portion on eccentric shaft end.

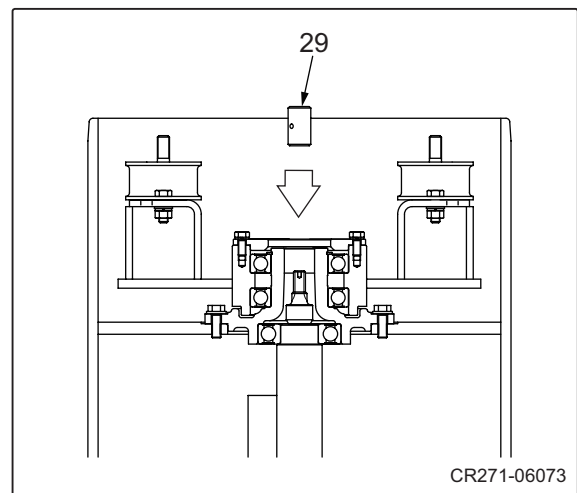

24) Lower vibrator motor (28) on mounting surface of cover.



Vibrator motor : 5 kg (11 lbs.)

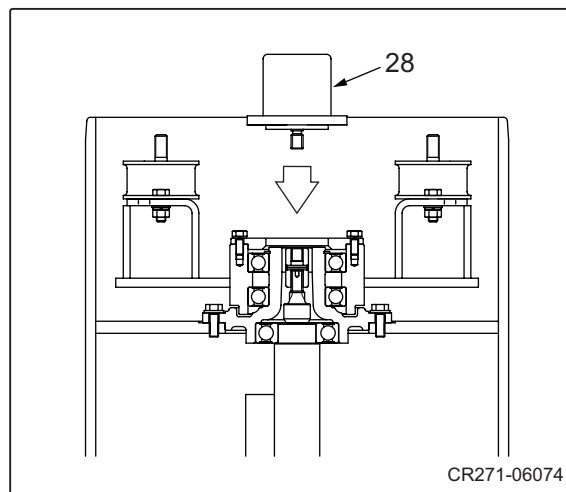

25) Secure vibrator motor (28) to cover with two bolts (27), spring washers and washers.



(27) Bolt : 62 N·m (46 lbf·ft)

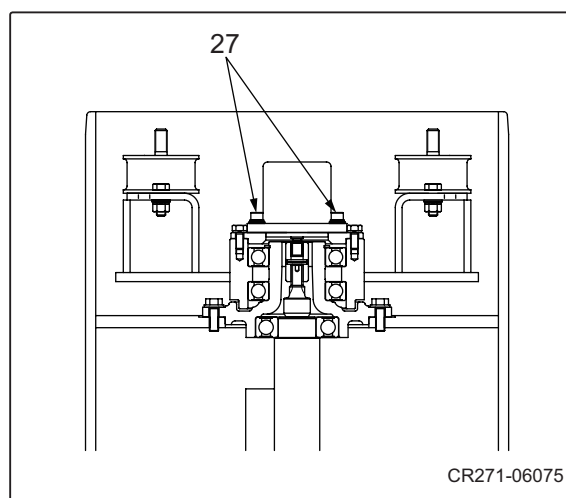

26) Secure bracket (15), (31) with nuts (14), (32), spring washers and washers.



(15), (31) Bracket : 25 kg (55 lbs.)



(14), (32) Nut : 157 N·m (116 lbf·ft)

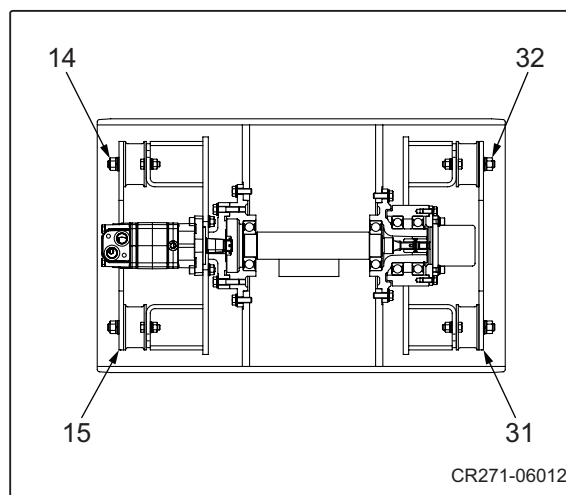

4-2-2. Rear drum

- Before reassembling, clean disassembled parts well and check that there is no abnormality.

WARNING

- When standing the vibratory drum, use wooden blocks of sufficient strength to securely support the drum.
- Carry out the work in an unstrained posture using a work stool or the like.

- 1) Stand drum (1) with its propulsion motor side facing up.



Drum : 225 kg (496 lbs.)

NOTE : Propulsion motor side dimension "b" : 298 mm (11.7 in.).

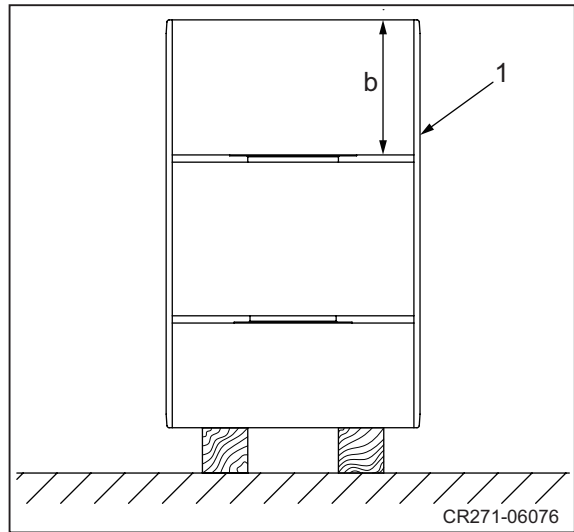

- 2) Install propulsion motor (32) to side plate SUB ASSY.



Propulsion motor : 15 kg (33 lbs.)

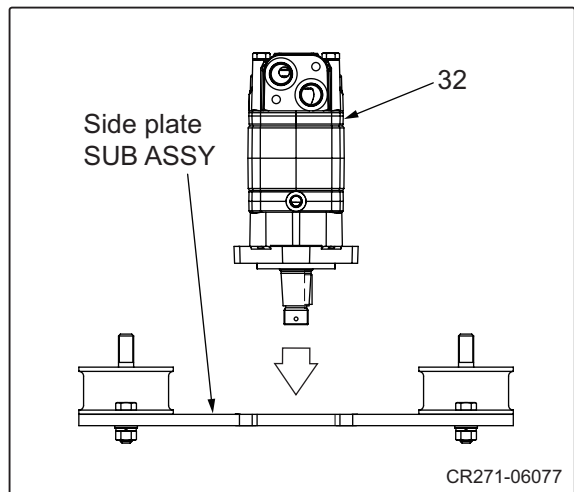

- 3) Secure propulsion motor (32) with four bolts (30), nuts (31) and washers.



(31) Nut : 108 N·m (80 lbf·ft)

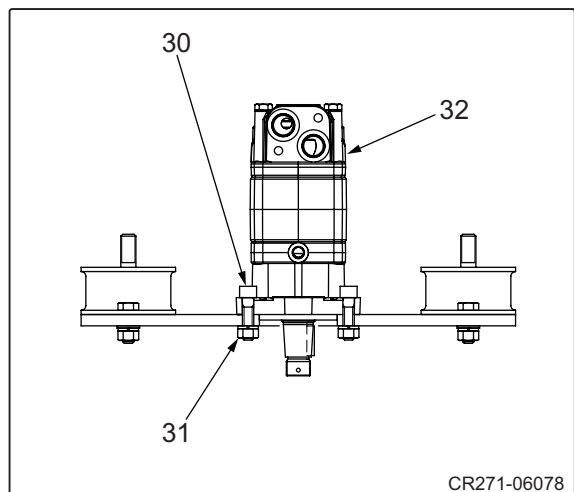

- 4) Install sunk key (2).
- Install flange (23).

 (23) Flange : 10 kg (22 lbs.)

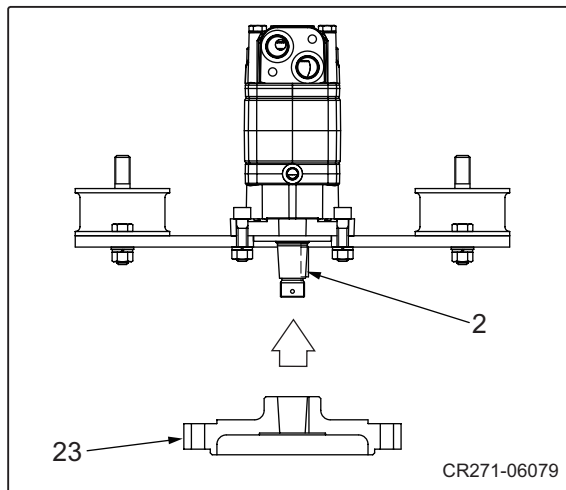

- 5) Secure flange (23) with castle nut (3) and washer.

 (3) Castle Nut : 200 N·m (147.5 lbf·ft)

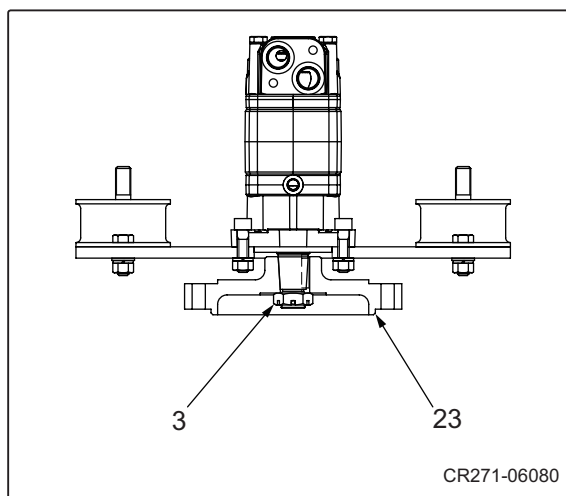

- Install split pin (4).

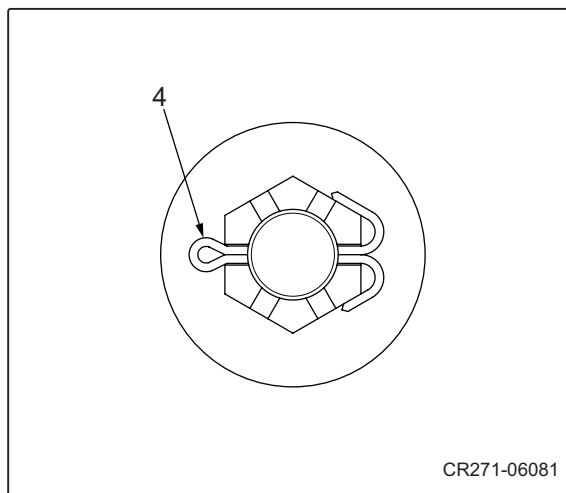

DRUMS

- 6) Lower propulsion motor SUB ASSY on mounting surface of drum.



Propulsion motor SUB ASSY : 35 kg (77 lbs.)

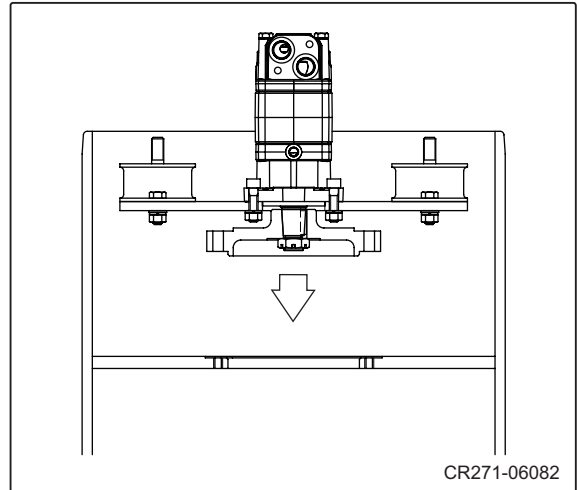

- 7) Secure propulsion motor SUB ASSY with bolts (29) and washers.

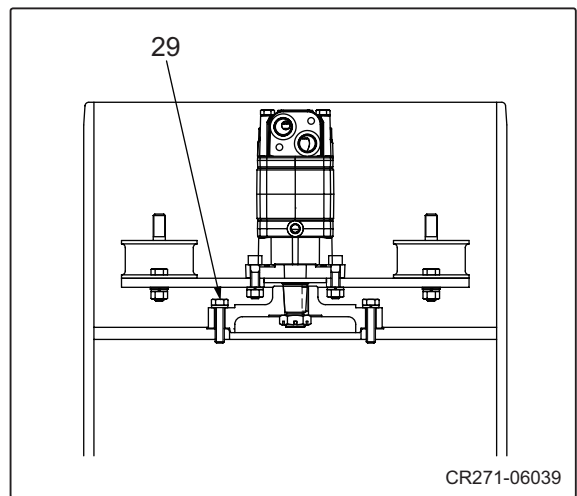

- Secure propulsion motor SUB ASSY with six bolts (29) and washers.



(29) Bolt : 108 N·m (80 lbf·ft)

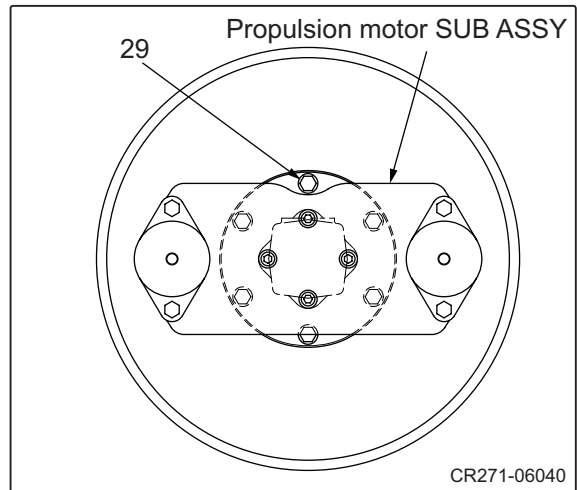

⚠ WARNING

Be careful because reversing the vibratory drum involves Risk. Confirm that the surrounding area is safe, and work in a natural, unstained posture.

8) Reverse drum SUB ASSY.



Drum SUB ASSY : 260 kg (573 lbs.)

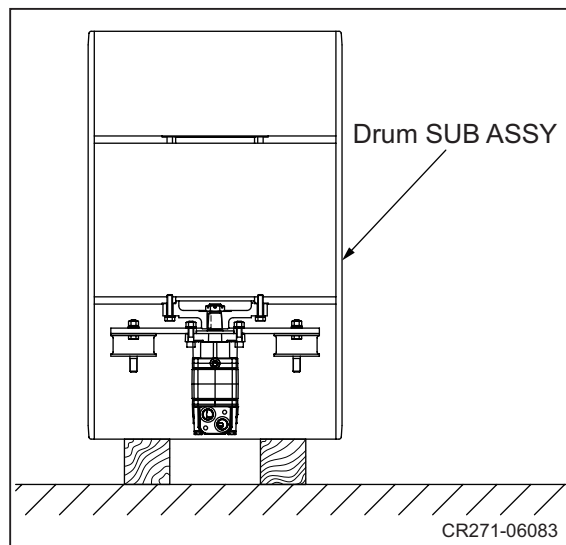

9) Apply a coat of gear oil to side plate (18) at where bearing will be press-fitted.

- Drive in bearing (12).

NOTE : Take care not to damage the bearing when installing it.

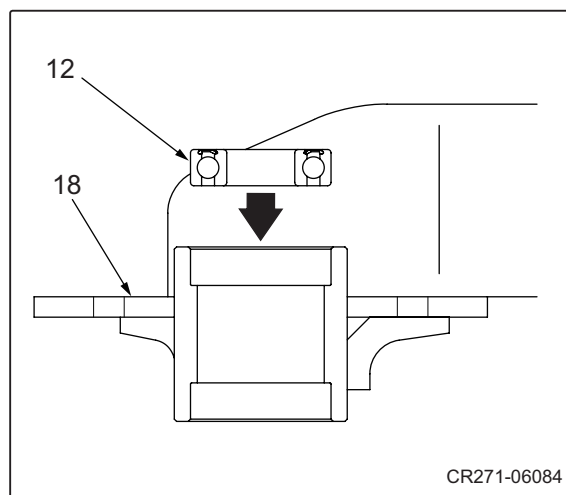

10) Reverse side plate SUB ASSY.



Side plate SUB ASSY : 20 kg (44 lbs.)

- Install disc plate (19).
- Apply a coat of gear oil to side plate SUB ASSY at where bearing will be press-fitted.
- Drive in flange SUB ASSY.

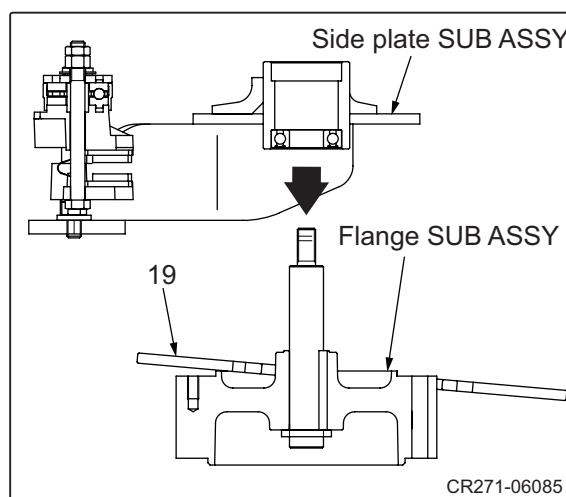

11) Install spacer (8).

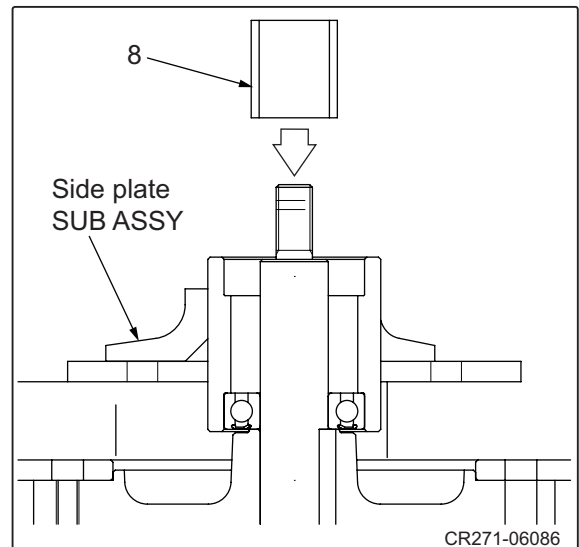

12) Fill the grease.

- Apply a coat of gear oil to side plate SUB ASSY at where bearing will be press-fitted.
- Drive in bearing (12).

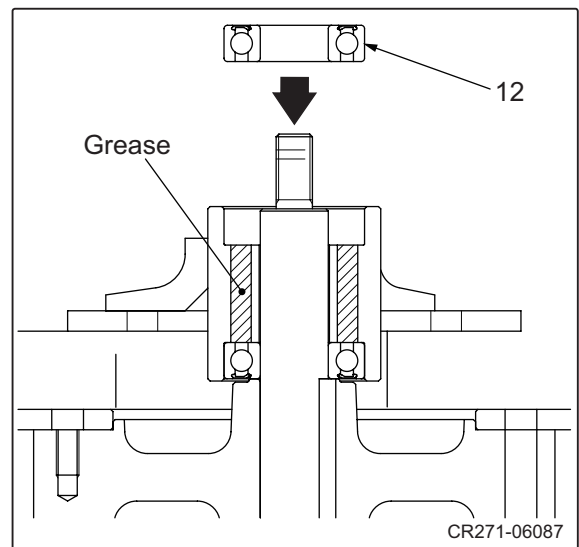

13) Install washer (9).

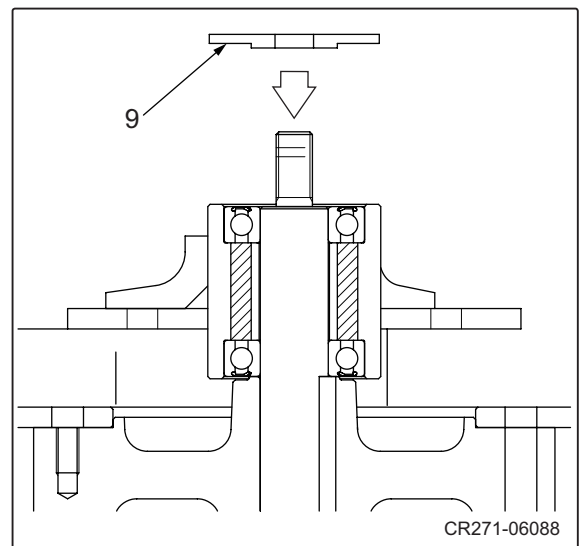

14) Secure washer with castle nut (10) and washers.

 (10) Castle nut : 106 N·m (78 lbf·ft)

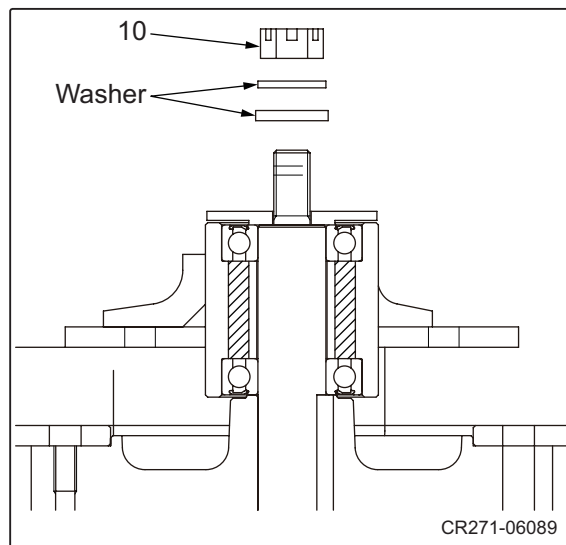

- Install split pin (11).

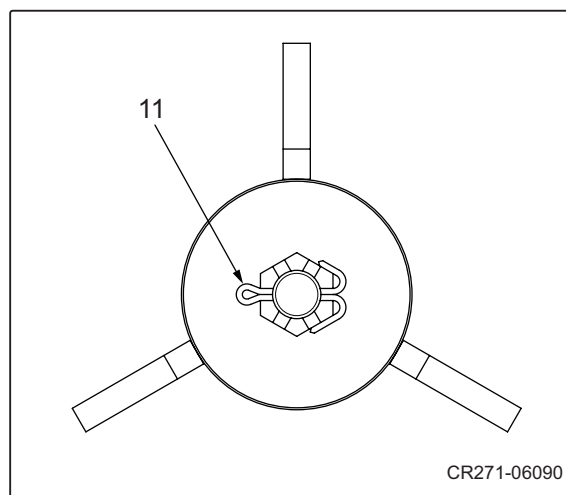

15) Install disc plate (19).

- Secure disc plate (19) with bolts (7) and washers.

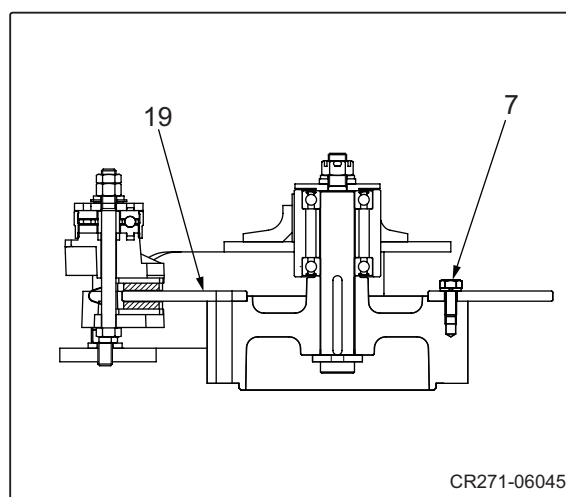

DRUMS

- Secure disc plate (19) with three bolts (7) and washers.

 (7) Bolt : 49 N·m (36 lbf·ft)

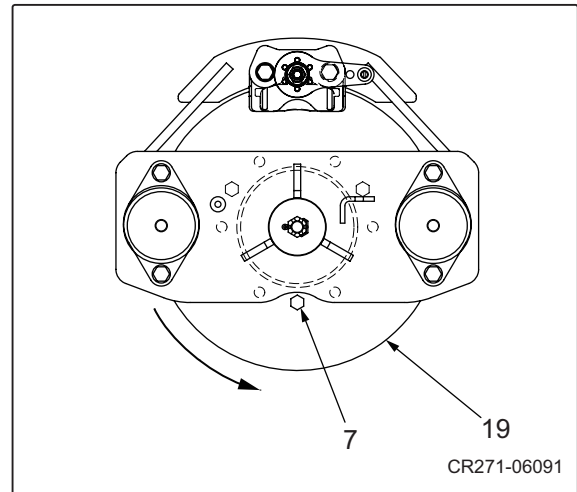

- 16) Install control cable.

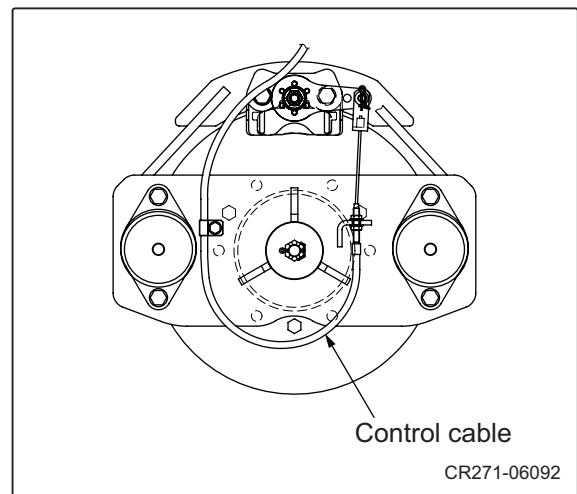

- 17) Lower disc brake SUB ASSY on mounting surface of drum.

 Disc brake SUB ASSY : 50 kg (110 lbs.)

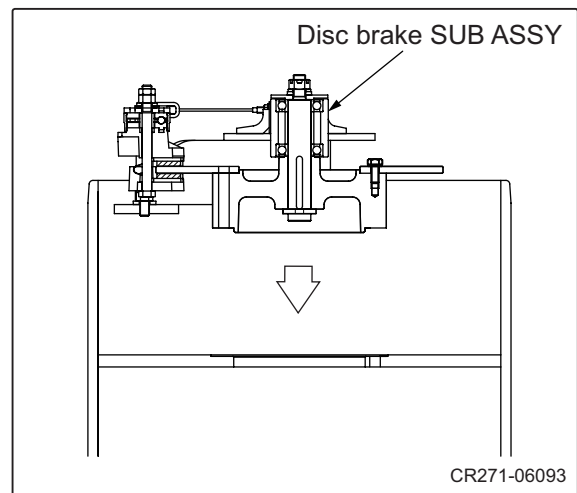

- Secure side plate SUB ASSY with bolts (13) and washers.

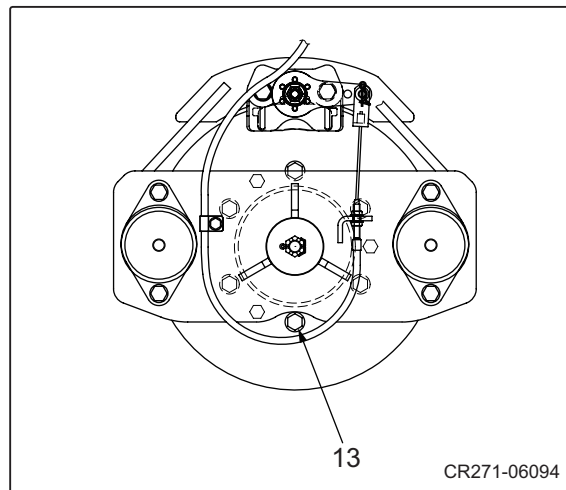

- Secure side plate SUB ASSY with six bolts (13) and washers.

 (13) Bolt : 108 N·m (80 lbf·ft)

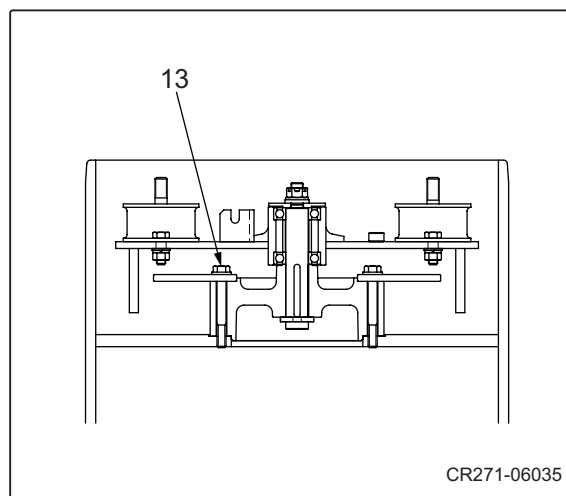

- 18) Secure bracket (6), (33) with nuts (14), (28), spring washers and washers.

 (6) Bracket : 30 kg (66 lbs.)

(33) Bracket : 20 kg (44 lbs.)

 (14), (28) Nut : 157 N·m (116 lbf·ft)

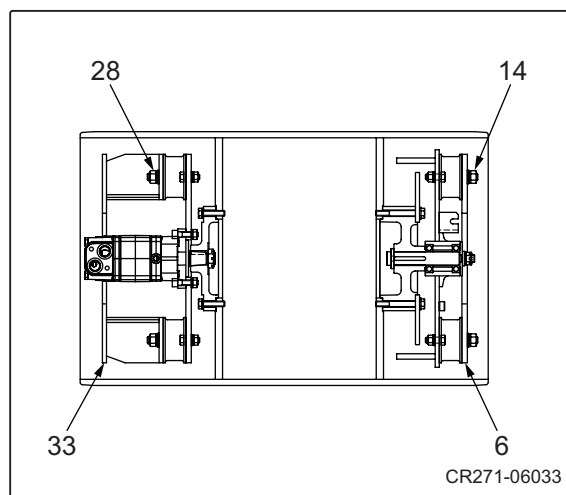

PARKING BRAKE

1. PARKING BRAKE

1-1. Brake

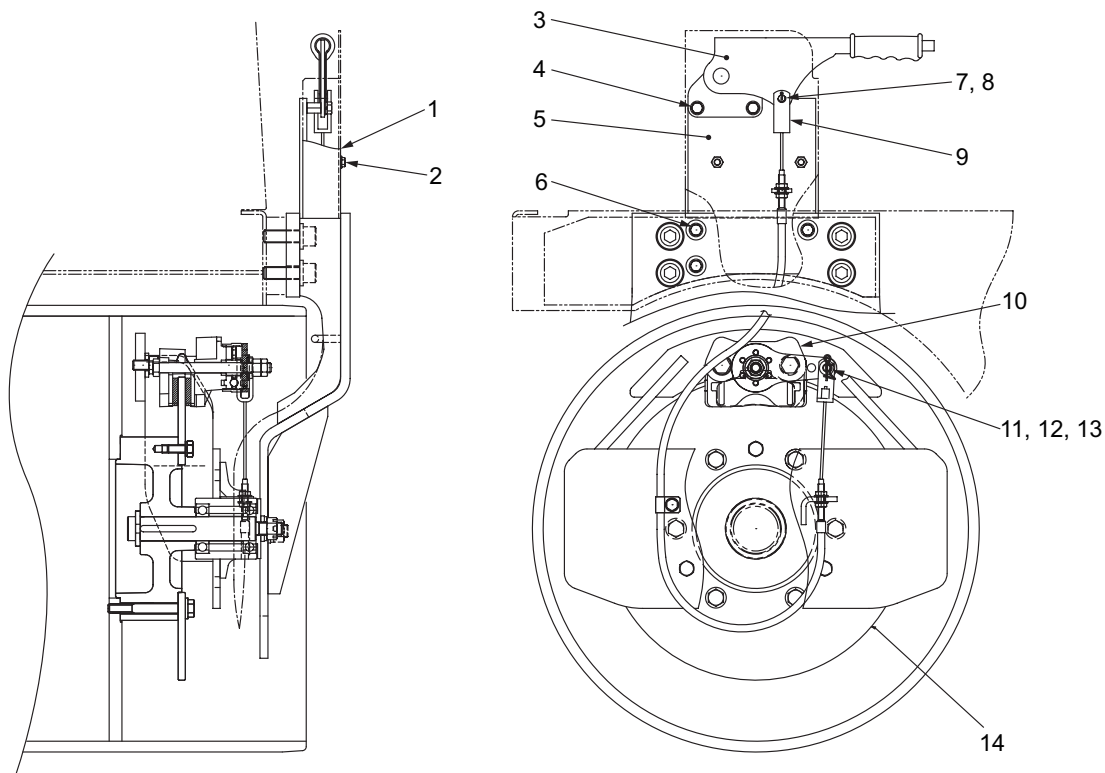

CR271-07001

- | | | |
|-----------------------------|---------|-------------------|
| (1) Cover | | (8) Split pin |
| (2) Bolt | : M8x20 | (9) Control cable |
| (3) Parking brake | | (10) Brake ASSY |
| (4) Bolt | : M8x20 | (11) Pin |
| (5) Parking brake base ASSY | | (12) R-pin |
| (6) Bolt | : M8x20 | (13) Washer |
| (7) Pin | | (14) Disc plate |

WATER SPRAY SYSTEM

1. WATER SPRAY SYSTEM

1-1. Water spray

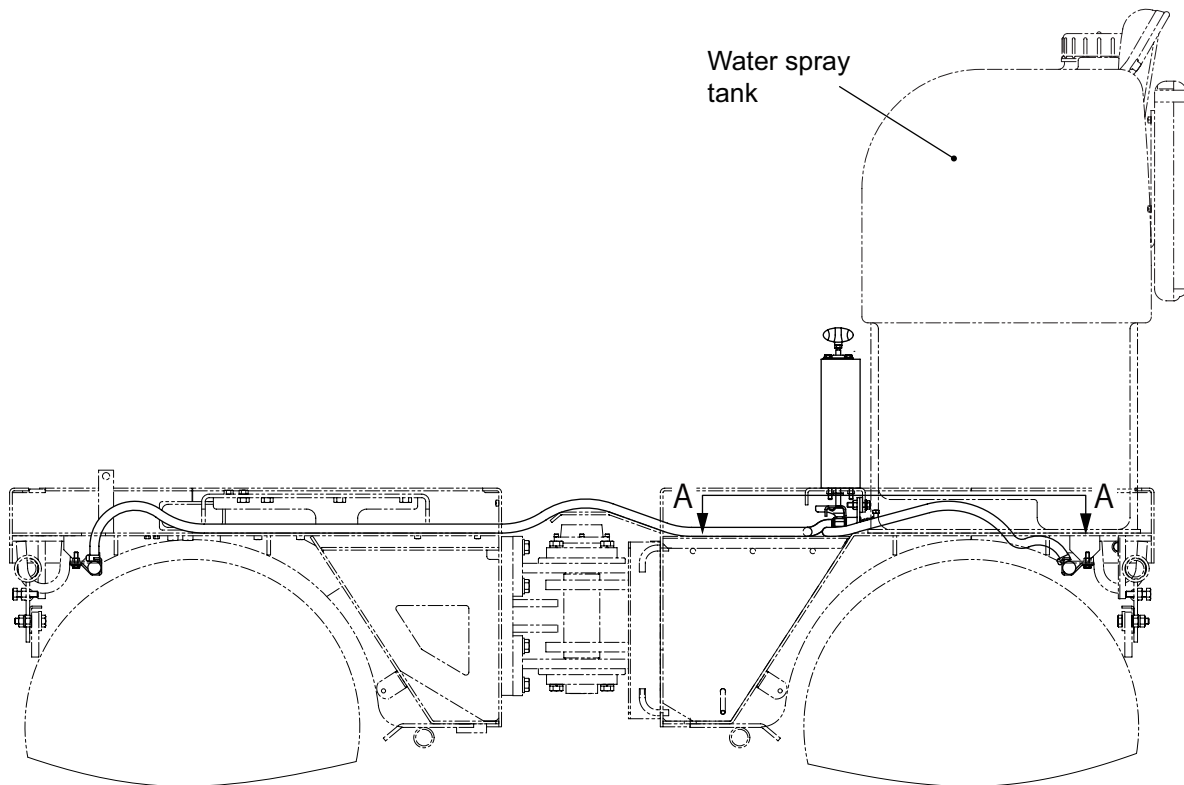
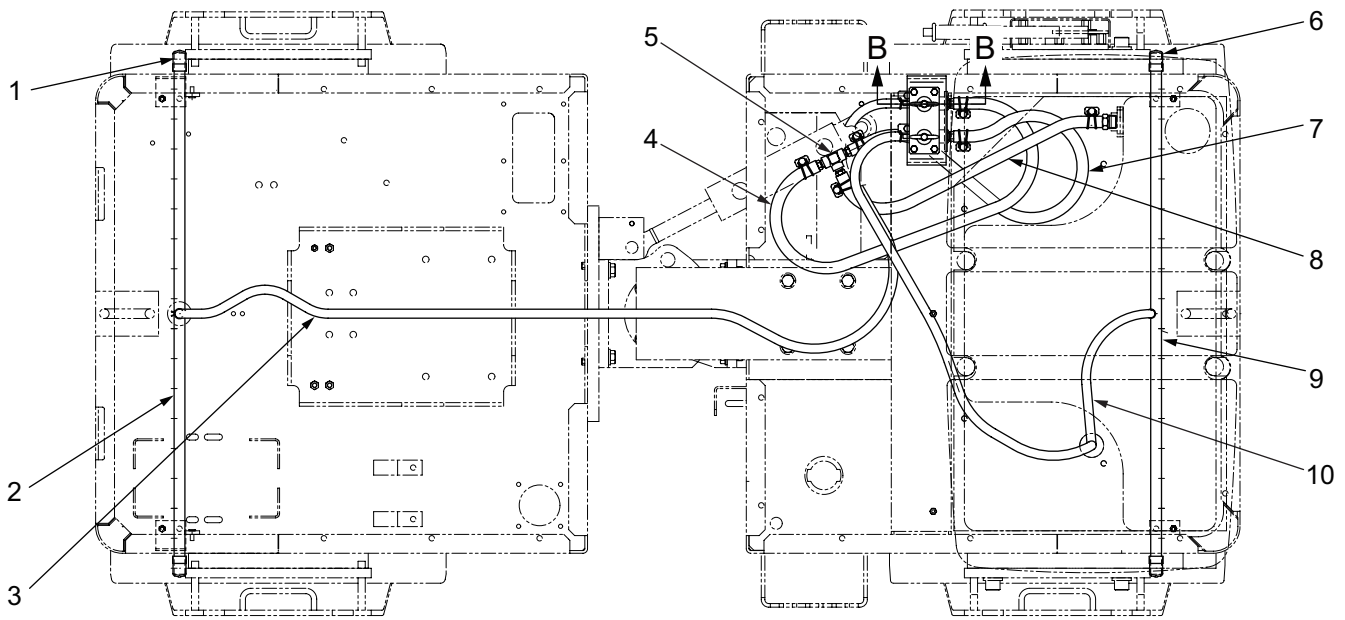

0563-75801-0-10190-F

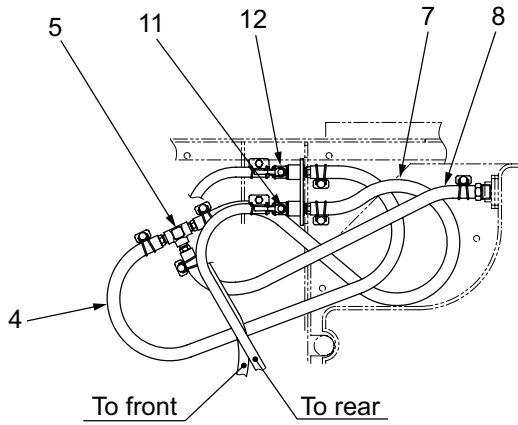

SECTION A-A

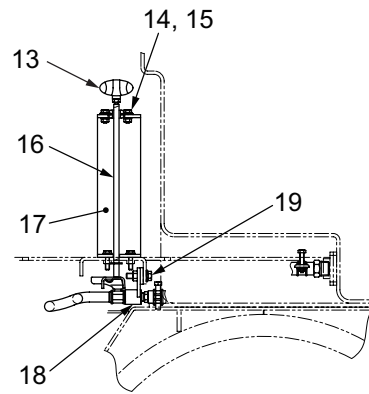

SECTION B-B

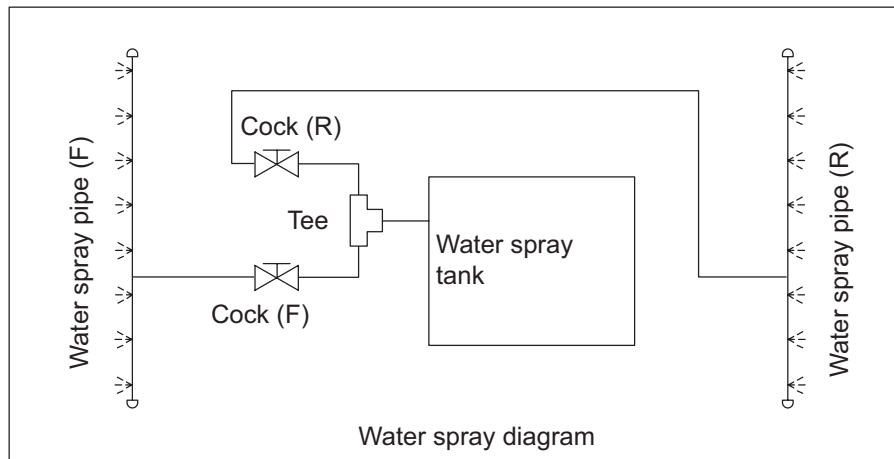

Water spray diagram

CR271-08001

- | | |
|---------------------------------|-------------------------|
| (1) Cap | (11) Cock (R) |
| (2) Pipe (F) | (12) Cock (F) |
| (3) Hose (Cock (F) → Pipe (F)) | (13) Wing knob |
| (4) Hose (Tee → Cock (F)) | (14) Bolt : M6x16 |
| (5) Tee | (15) Nut |
| (6) Cap | (16) Control lever ASSY |
| (7) Hose (Tee → Cock (R)) | (17) Stand ASSY |
| (8) Hose (Tank → Tee) | (18) Valve stand ASSY |
| (9) Pipe (R) | (19) Bolt : M6x12 |
| (10) Hose (Cock (R) → Pipe (R)) | |

INSPECTION AND ADJUSTMENT

1. INSPECTION AND ADJUSTMENT

1-1. Safety Precautions for Inspection and Adjustment

WARNING

Unexpected machine movement may cause a serious accident. When inspecting the machine while the engine is running, always follow the instructions below.

- Park the machine on level, flat ground.
- Apply the parking brake.
- Set chocks in front and behind each drum or tire.
- Make sure that service personnel are given the appropriate information at the appropriate time.
- Make sure that no one can enter any hazardous area.

CAUTION

Do not work on the hydraulic system while the engine is running and the system is hot and under pressure. Do not disconnect hydraulic hoses or fittings until the system has cooled and pressure has been properly relieved.

Before removing any plugs from the pressure measurement ports, always release any residual pressure from the piping and open the cap of the fluid tank to release and pressure.

WARNING

Inadvertent starting the engine may cause a serious accident.

When inspecting the engine, make sure to exchange the appropriate cues and hand signal with the person at the operator station to avoid any accidents.

CAUTION

Before inspecting inside of the engine compartment, always stop the engine.

Contact with the fan, V-belt or exhaust system parts while the engine is running may cause serious injury.

1-2. Preparation for Inspection and Adjustment

- Prepare the necessary measuring instruments. In addition, particularly when measuring pressure values, make sure to prepare the appropriate hoses, adapters and a plug removal tool for the pressure reading port.
- Make sure that the instruments to be used operate normally.

When handling the instruments, exercise sufficient caution not to drop or apply any impact to them. Doing so may adversely affect the calibration. Another important point is to inspect the instruments regularly. An instrument that does not start from the appropriate zero point may give an inaccurate reading.

1-3. Precautions for Inspection and Adjustment

- When performing inspections and adjustments, pay special attention to safety.
- For each inspection, always take three measurements for each measurement point. If the measurements significantly differ, the measurement method may be incorrect. In such a case, take measurements once again and calculate their average.

1-4. Warm-up

- Machinery will not exhibit their true performance under the cold condition. Before taking measurements, always warm up the engine and make sure that the fluid and engine coolant are warmed to their specified normal operating temperatures.

1-5. Inspection and Adjustment of Engine Related Items

- Refer to shop manual of engine manufacturer for inspection and adjustment of engine itself.

2. MEASUREMENT AND INSPECTION OF PROPULSION CIRCUIT PRESSURE

2-1. Measurement

⚠ WARNING

Confirm that the parking brake works properly before measurement.

- Oil temperature during measurement : $50 \pm 5^{\circ}\text{C}$ ($122 \pm 9^{\circ}\text{F}$)
- ① Remove plugs from high pressure gauge port (1-2) and (1-1) of propulsion pump. Attach pressure gauge with adapter (y) .
 - Adapter : 7/16-20UNF
 - High pressure gauge port (Reverse) : (1-2)
 - High pressure gauge port (Forward) : (1-1)
 - Pressure gauge : 0 to 25 MPa (0 to 3,625 psi)
- ② Start the engine and set throttle lever to "FULL".
- ③ Establish a condition in which machine propulsion load becomes maximum.
(Pressure does not build up unless propulsion load is applied.)
- ④ With propulsion load at maximum, slowly move F-R lever to the side to be measured.
 - Then, read pressure indicated by pressure gauge.
- ⑤ After measuring, promptly return F-R lever to "N".

★ Maximum circuit pressure

(high pressure relief valve setting)

: 17.2 ± 1.0 MPa ($2,494 \pm 145$ psi)

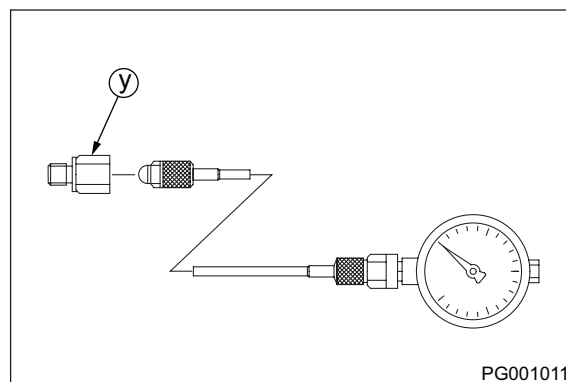
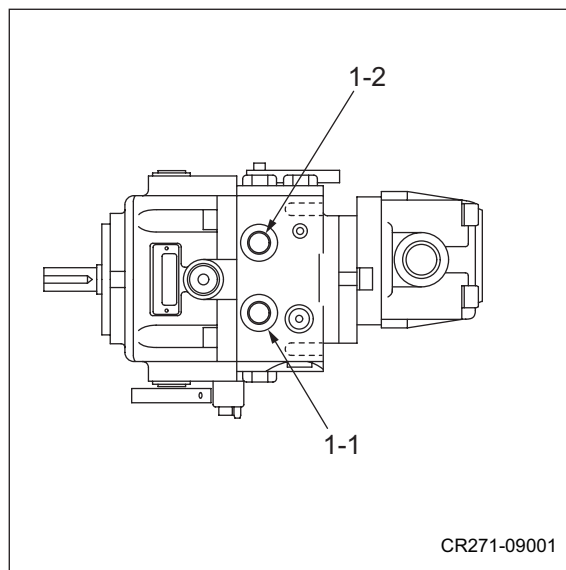

- The number "1-1" and "1-2" appearing in above illustrations are consistent with lead line number shown in illustration of propulsion pump in "2-2. Hydraulic Component Specifications" (page 4-006).

2-2. Inspection

- If measurement results indicate the pressure deviating from maximum circuit pressure range, make an inspection in accordance with procedure described below.
 - ① Remove plug and valve from high pressure relief valve (1-5) or (1-6) of propulsion pump.
 - High pressure relief valve : (1-5)
(Forward)
 - High pressure relief valve : (1-6)
(Reverse)
 - ② Check removed high pressure relief valve for trapped dirt and other abnormalities.
 - ③ If trapped dirt is present, disassemble and clean high pressure relief valve.
 - ④ If pressure still deviates from maximum circuit pressure range after valve is disassembled and cleaned, replace high pressure relief valve.
 - ⑤ After inspection, measure pressure again and check that pressure reaches maximum circuit pressure range.

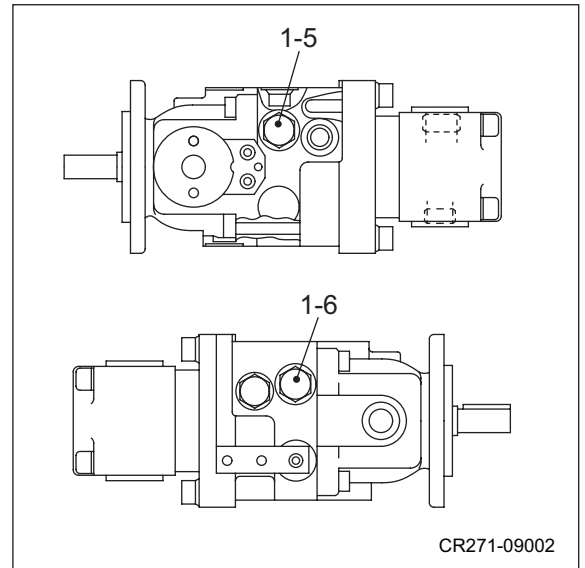

Plug : 78 N·m (57.5 lbf·ft)

(NOTICE)

- **Carefully disassemble and reassemble after taking steps to prevent foreign material from getting in.**
- The numbers “1-5” and “1-6” appearing in above illustrations are consistent with lead line numbers shown in illustration of propulsion pump in “2-2. Hydraulic Component Specifications” (page 4-006).

3. MEASUREMENT AND INSPECTION OF PROPULSION CHARGE CIRCUIT PRESSURE

- Since oil in charge circuit is supplied from steering circuit, confirm that steering operation is normal before measurement.

3-1. Measurement

- Oil temperature during measurement : $50 \pm 5^{\circ}\text{C}$ ($122 \pm 9^{\circ}\text{F}$)
- ① Remove plug from propulsion pump charge pressure gauge port (1-8). Attach pressure gauge with adapter (Y) .
 - Adapter for (Y) : 7/16-20UNF
 - Pressure gauge : 0 to 5 MPa (0 to 725 psi)
- ② Apply brake by parking brake lever.
- ③ Start the engine and set throttle lever to "FULL".
 - Then, read pressure indicated by pressure gauge.

★ Standard charge relief valve setting
: 0.5 MPa (72.5 psi)

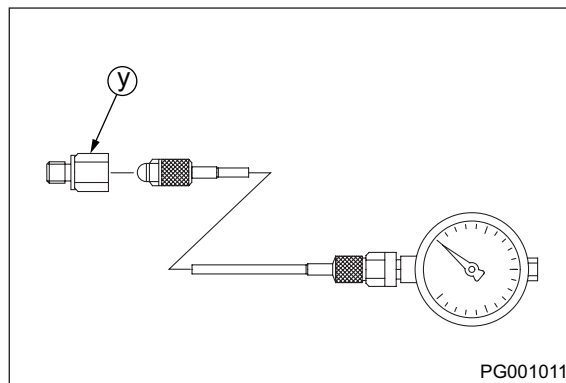
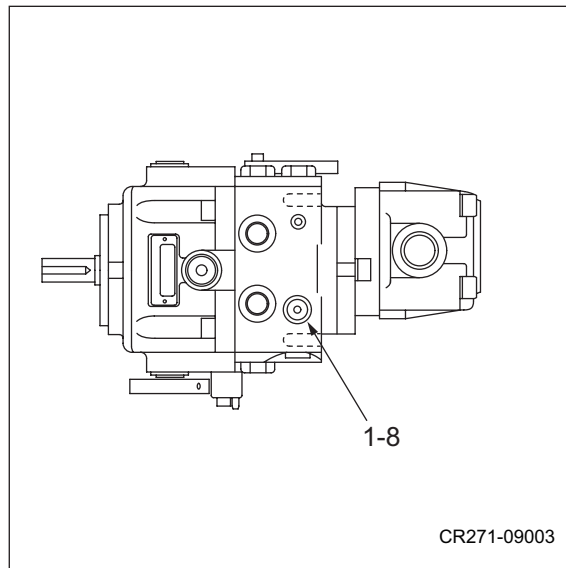

- The number "1-8" appearing in above illustrations is consistent with lead line numbers shown in illustration of propulsion pump in "2-2. Hydraulic Component Specifications" (page 4-006).

3-2. Inspection

- If measurement results indicate the pressure deviating from standard charge relief valve setting range, make an inspection in accordance with procedure described below.

- ① Remove plug and charge pressure relief valve (1-9).
- ② Check removed charge relief valve for trapped dirt and other abnormalities.
- ③ If trapped dirt is present, disassemble and clean charge pressure relief valve.
- ④ If pressure still deviates from standard charge relief valve setting range after valve is disassembled and cleaned, replace charge pressure relief valve.
- ⑤ After inspection, measure pressure again and check that pressure reaches standard charge relief valve setting range.



Plug : 78 N·m (57.5 lbf·ft)

(NOTICE)

- **Carefully disassemble and reassemble after taking steps to prevent foreign material from getting in.**

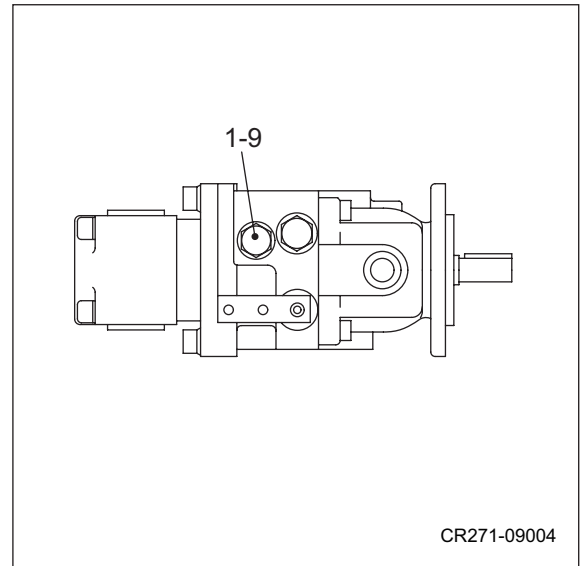

4. MEASUREMENT AND ADJUSTMENT OF STEERING CIRCUIT PRESSURE

4-1. Measurement

⚠ WARNING

Make sure that there is no person around the articulated portion of the machine before operating the steering wheel.

- Oil temperature during measurement : $50 \pm 5^{\circ}\text{C}$ ($122 \pm 9^{\circ}\text{F}$)
- ① Disconnect hose (1) from line filter. Attach pressure gauge through adapter m .
 - Adapter m : G1/4
 - Pressure gauge : 0 to 10 MPa (0 to 1,450 psi)
- ② Confirm that F-R lever is in "N" properly.
- ③ Start the engine and set throttle lever to "FULL".
- ④ Turn steering wheel to operate relief valve.
 - Then, read pressure indicated by pressure gauge.

★ **Standard maximum circuit pressure**
(Orbitroll relief pressure + charge relief pressure)
: 8.5 ± 1.0 MPa ($1,233 \pm 145$ psi)

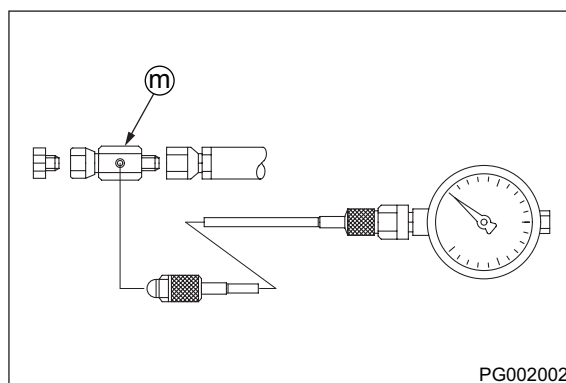
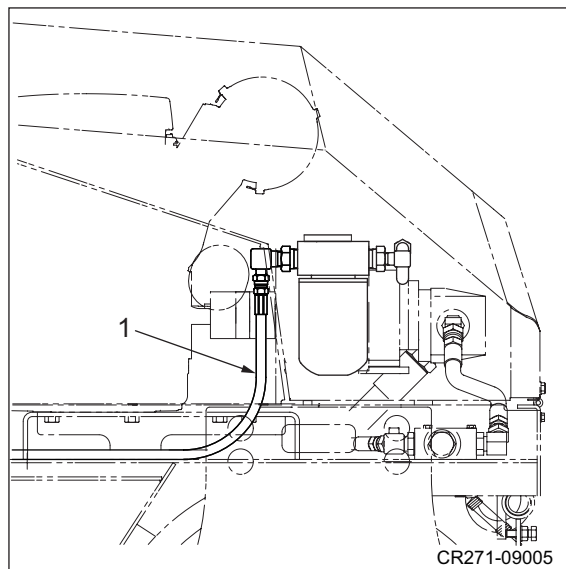

4-2. Adjustment

- If measurement results indicate the pressure deviating from standard maximum circuit pressure range, make an adjustment in accordance with procedure described below.
 - ① Check relief valve (2) for evidence of having loosened.
 - ② If there is evidence of relief valve having loosened, adjust it so that pressure becomes within standard maximum circuit pressure range while watching pressure gauge.
 - To adjust pressure, loosen adjustment plug (3).
 - Adjustment plug turned clockwise
: Pressure rise
 - Adjustment plug turned counterclockwise
: Pressure drop
 - Pressure change rate : 1.8 MPa/turn (261 psi/turn)
 - ③ If there is no evidence of having loosened, remove relief valve.
 - ④ Check removed relief valve for trapped dirt and scratches on its seat.
 - ⑤ If trapped dirt is present, disassemble and clean relief valve.
 - ⑥ If a scratch is found on seat, replace relief valve.
 - ⑦ After adjustment, measure pressure again and check that pressure reaches standard maximum circuit pressure range.

(NOTICE)

- **Carefully disassemble and reassemble after taking steps to prevent foreign material from getting in.**

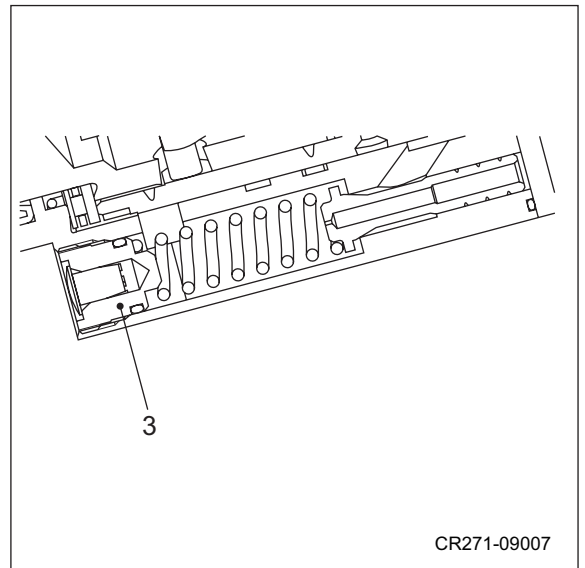
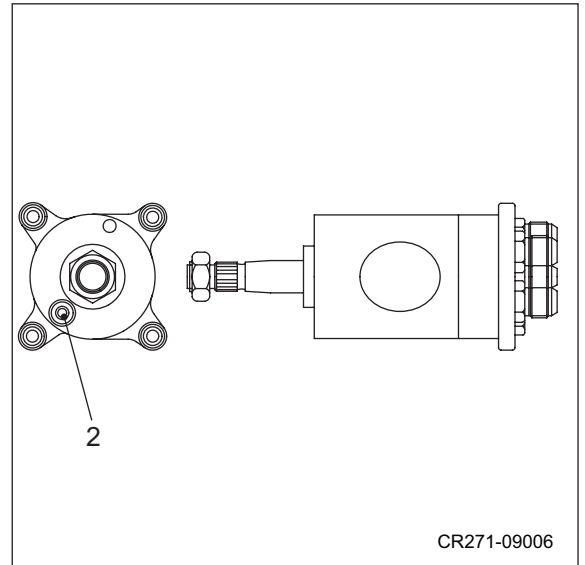

5. MEASUREMENT OF HYDRAULIC PUMP CASE PRESSURE

5-1. Measurement

- Oil temperature during measurement : $50 \pm 5^{\circ}\text{C}$ ($122 \pm 9^{\circ}\text{F}$)
- ① Disconnect hose (1) from propulsion pump. Attach pressure gauge through adapter (n) .
 - Adapter (n) : G3/8
 - Pressure gauge : 0 to 5 MPa (0 to 725 psi)
- ② Start the engine and set throttle lever to "FULL".
- ③ Establish a condition in which machine propulsion load becomes maximum.
(Pressure does not build up unless propulsion load is applied.)
- ④ With propulsion load at maximum, measure pressure when F-R lever is in "N", "F", and "R", respectively.

★ Pump case pressure : 0.1 MPa (14.5 psi)

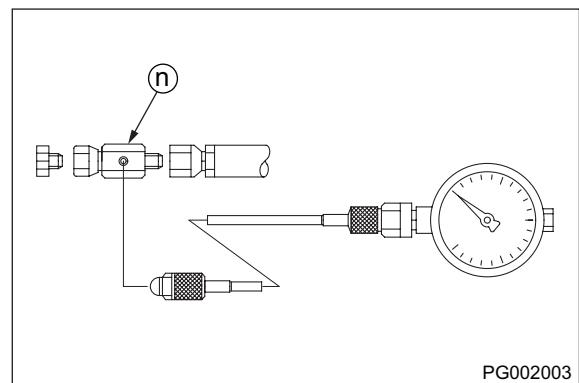
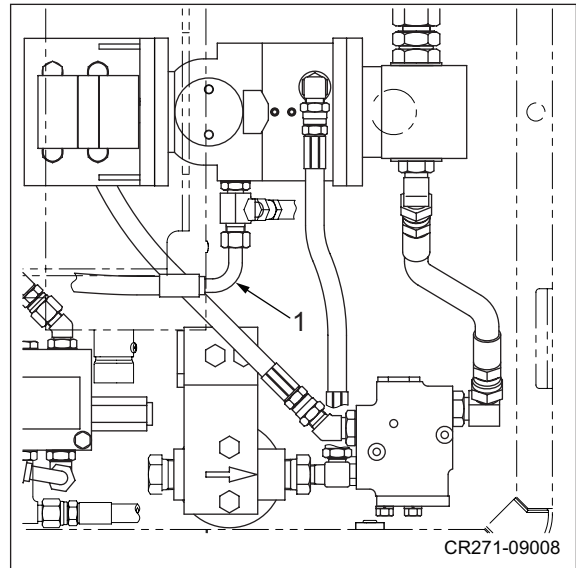

6. MEASUREMENT OF PROPULSION MOTOR CASE PRESSURE

6-1. Measurement

- Oil temperature during measurement : $50 \pm 5^{\circ}\text{C}$ ($122 \pm 9^{\circ}\text{F}$)
- ① Disconnect hose (1) from propulsion pump. Attach pressure gauge through adapter (m) .
 - Adapter (m) : G1/4
 - Pressure gauge : 0 to 25 MPa (0 to 3,625 psi)
- ② Start the engine and set throttle lever to "FULL".
- ③ Establish a condition in which machine propulsion load becomes maximum.
(Pressure does not build up unless propulsion load is applied.)
- ④ With propulsion load at maximum, measure pressure when F-R lever is in "N", "F", and "R", respectively.

★ **Motor case pressure : 14 MPa (2,030 psi)**

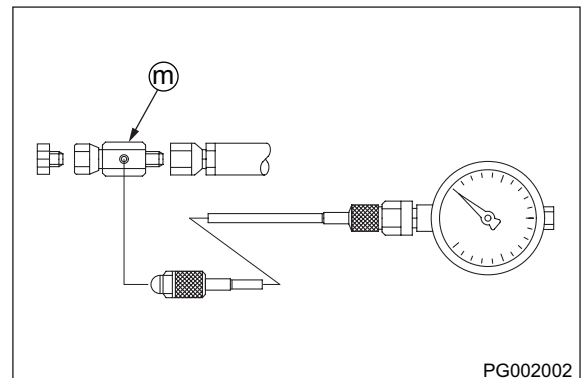
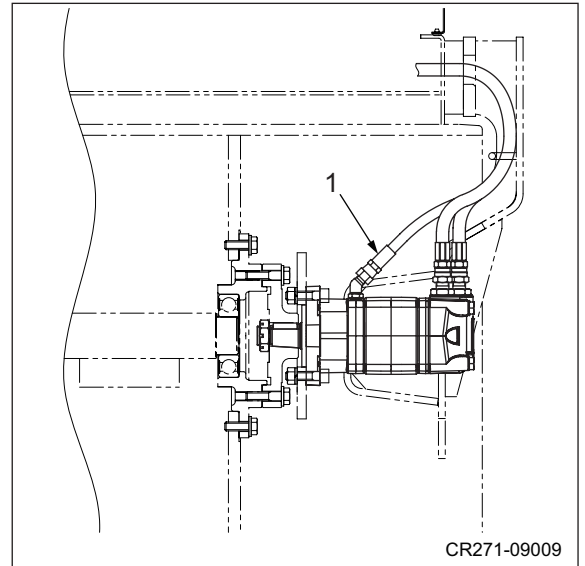

7. ADJUSTMENT OF THROTTLE LEVER LINKAGE

7-1. Adjustment

- In cases such as maximum no-load rotational speed or minimum no-load rotational speed deviating from standard value, control cable is replaced, or throttle lever does not move smoothly, make an adjustment in accordance with procedure described below.
- Make the adjustment after amply warming up engine.
- Oil temperature during measurement : $50 \pm 5^{\circ}\text{C}$ ($122 \pm 9^{\circ}\text{F}$)

- ① Set throttle lever (1) to "IDLE".
- ② Attach control cable (2) to throttle lever (1).

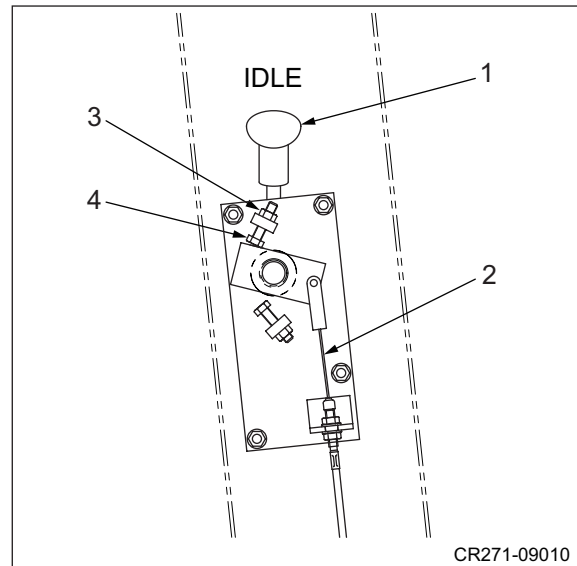

- ③ Attach control cable (2) to control lever (5) of control ASSY on the engine side.
- ④ Start the engine.
- ⑤ Loosen lock nut (3).
- ⑥ Using stopper bolt (IDLE) (4), adjust so that standard minimum no-load rotational speed is achieved.

★ **Standard minimum no-load rotational speed**
: $1,400 \pm 150$ rpm

- ⑦ Using lock nut (3), firmly secure stopper bolt (4).

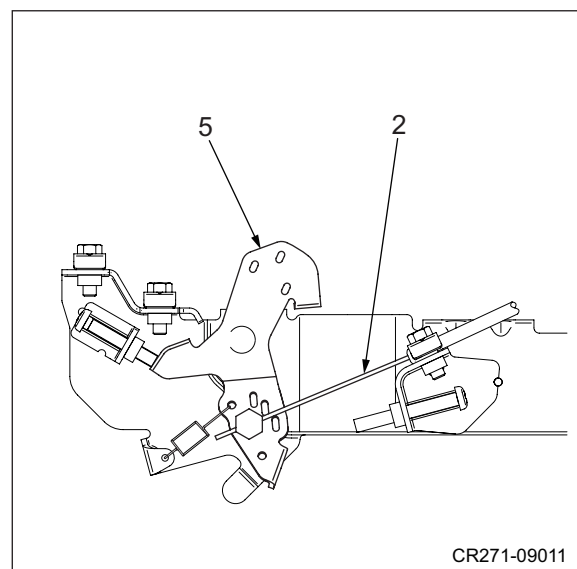

- ⑧ Set throttle lever (1) to "FULL".
- ⑨ Loosen lock nut (7).

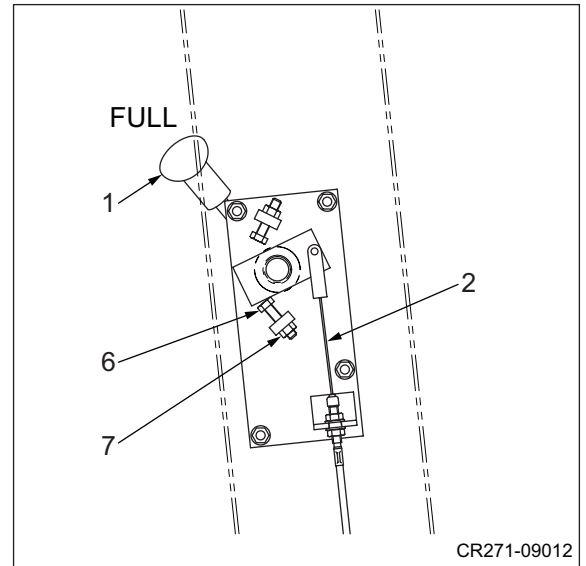

- ⑩ Using stopper bolt (FULL) (6), adjust so that control lever (8) contacts stopper (9).
- ⑪ Confirm that the engine speed is within standard range.

★ **Standard minimum no-load rotational speed**
: $3,850 \pm 150$ rpm

- ⑫ Using lock nut (7), firmly secure stopper bolt (6).

(NOTICE)

- If maximum no-load rotational speed is not in standard range even when control lever (8) is against stopper (9), adjust control linkage, or repair or replace them.

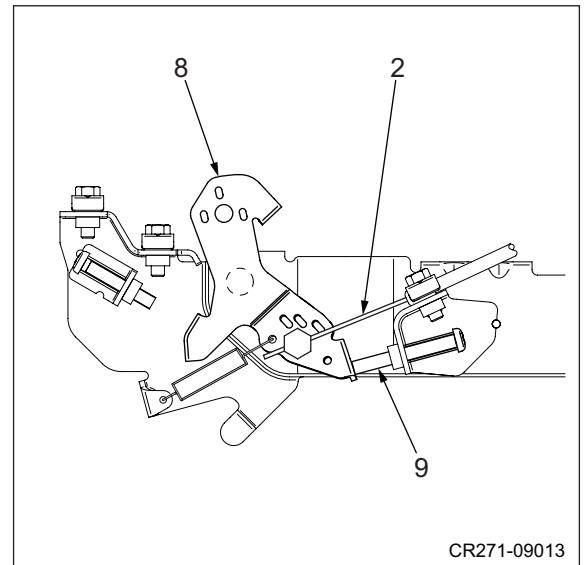

8. ADJUSTMENT OF F-R LEVER LINKAGE

8-1. Adjustment

- In cases such as propulsion hydraulic pump is replaced, control cable is replaced or F-R lever does not move smoothly, make an adjustment in accordance with procedure described below.
- “N” positions of F-R lever (1) are positioned by notches.

① Set F-R lever (1) “N”.

② Attach control cable (2) to F-R lever.

★ Specified dimension a : 170 mm (6.7 in.)

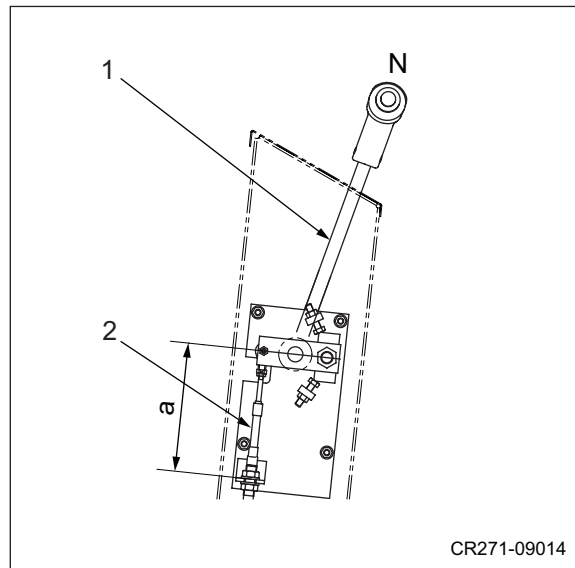

③ Attach control cable (2) to propulsion pump control lever (3).

★ Specified dimension b : 170 mm (6.7 in.)

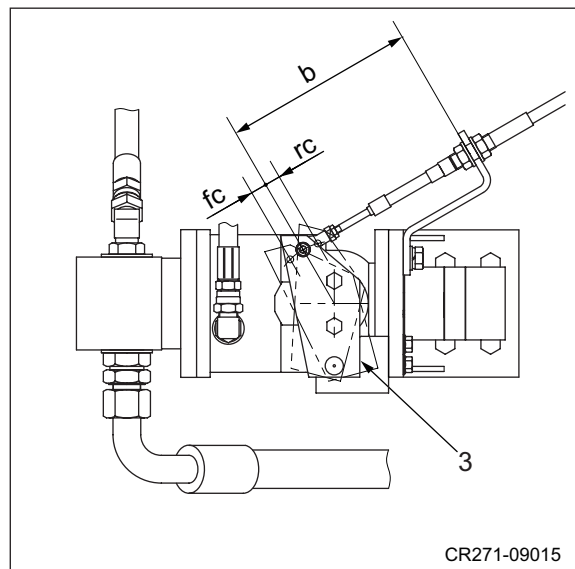

- ④ Loosen lock nut (4).
- ⑤ Shift F-R lever to "F" direction until propulsion pump control lever (3) moves specified dimension "fc" in forward direction.
- ⑥ Contact stopper bolt (5) to F-R lever.
- ⑦ Using lock nut (4), firmly secure stopper bolt (5).

★ Specified dimension fc : 14 mm (0.55 in.)

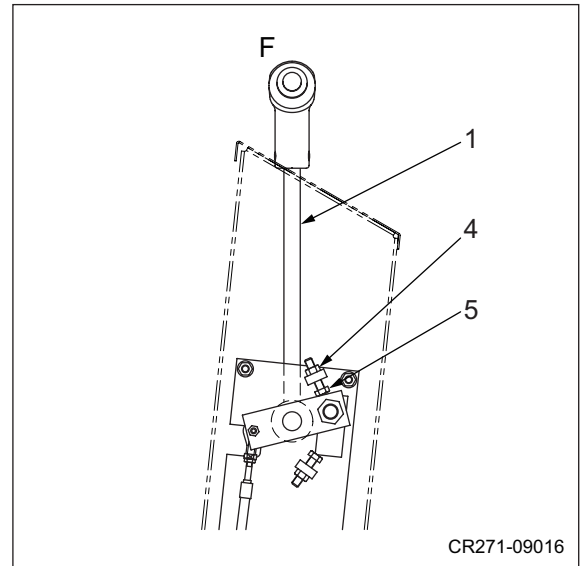

- ⑧ Loosen lock nut (7).
- ⑨ Shift F-R lever to "R" direction until propulsion pump control lever (3) moves specified dimension "rc" in reverse direction.
- ⑩ Contact stopper bolt (6) to F-R lever
- ⑪ Using lock nut (7), firmly secure stopper bolt (6).

★ Specified dimension rc : 14 mm (0.55 in.)

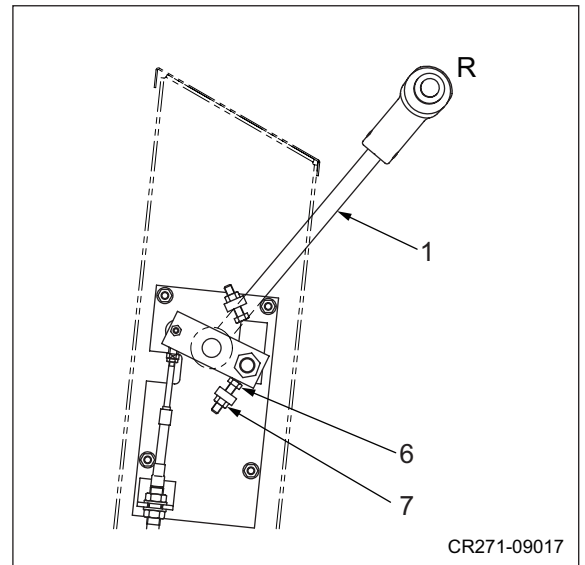

TROUBLESHOOTING

1. TROUBLESHOOTING

1-1. Safety Precautions for Troubleshooting

WARNING

Unexpected machine movement may cause a serious accident. When inspecting the machine while the engine is running, always follow the instructions below.

- Park the machine on level, flat ground.
- Apply the parking brake.
- Set chocks in front and behind each drum or tire.
- Make sure that service personnel are given the appropriate information at the appropriate time.
- Make sure that no one can enter any hazardous area.

CAUTION

Do not work on the hydraulic system while the engine is running and the system is hot and under pressure. Do not disconnect hydraulic hoses or fittings until the system has cooled and pressure has been properly relieved.

Before removing any plugs from the pressure measurement ports, always release any residual pressure from the piping and open the cap of the fluid tank to release and pressure.

WARNING

Inadvertent starting the engine may cause a serious accident.

When inspecting the engine, make sure to exchange the appropriate cues and hand signal with the person at the operator station to avoid any accidents.

CAUTION

Before inspecting inside of the engine compartment, always stop the engine.

Contact with the fan, V-belt or exhaust system parts while the engine is running may cause serious injury.

1-2. Important Information for Troubleshooting

Before conducting troubleshooting, it is important to carefully read the operation manual and workshop manual and understand the electric circuits for each component as well as the structure and function of each system. Sufficient knowledge of the systems will enable you to identify a possible cause much faster. A fault or problem may seem to be related to many different factors. To identify the true cause, some experience is needed. To perform the appropriate troubleshooting, it is important to learn not only the normal operations of the systems but also the possible symptoms that may occur when an abnormal condition is present.

This chapter explains the possible causes and remedies for likely incidents taken from past experience.

1-3. Before Starting

The information in this section is provided to assist the troubleshooter in understanding the systems and quickly determine the causes when operating abnormalities occur.

The following steps are recommended:

1. If not familiar with the machine, study the Operator's Manual and this Shop Manual.
2. Check with the operator for full details of the trouble, ask questions.
3. Verify the trouble by warming up the machine and operating it. Check the problem yourself.
4. Identify the problem with either a mechanical, hydraulic or electrical system source.
5. Isolate the problem to a particular component or circuit.
6. Eliminate the simplest or easiest to check possibilities first to prevent unnecessary disassembly of components.
7. Following repair or replacement of any parts, perform operational tests to verify that the problem has been eliminated and the performance of all the systems is normal.

1-4. Wire Number and Color Code

Refer to "1-1. Wire Numbers, Wire Sizes, Wire Colors and Connectors Shown in Electrical Circuit Diagram, Wiring Harness Layout and Wiring Harnesses" of ELECTRICAL SYSTEM.

2. ELECTRICAL SYSTEM TROUBLESHOOTING

2-1. When Performing Electrical System Fault Diagnosis

⚠ WARNING

Be very careful because equipment can return to normal during an inspection and suddenly operate properly when a failure occurs due to a faulty contact or other such cause.

2-1-1. Precautions to take during electrical circuit fault diagnosis

- When disconnecting or connecting a connector, be sure to turn the power supply OFF. (Electronic control parts such as the engine control unit, in particular, could be damaged internally.)
- Since connectors are not numbered, be sure to affix alignment marks so that you can restore them to their original condition.
- Before making a diagnosis, check related connectors for faulty connections. (Check by disconnecting and reconnecting related connectors several times.)
- Before proceeding to the next step, be sure to return the disconnected connectors to their original condition.
- When diagnosing a circuit (measuring the voltage, resistance, continuity and current), move related wiring and connectors several times, and check whether the tester's numerical values change. (If values change, faulty contact in the circuit is possible.)
- Do not ground the circuit of the control unit or apply voltage to it unless otherwise specified.

2-1-2. Inspection procedures using a tester

Some of the various inspection procedures are presented here for reference, using a sample circuit below.

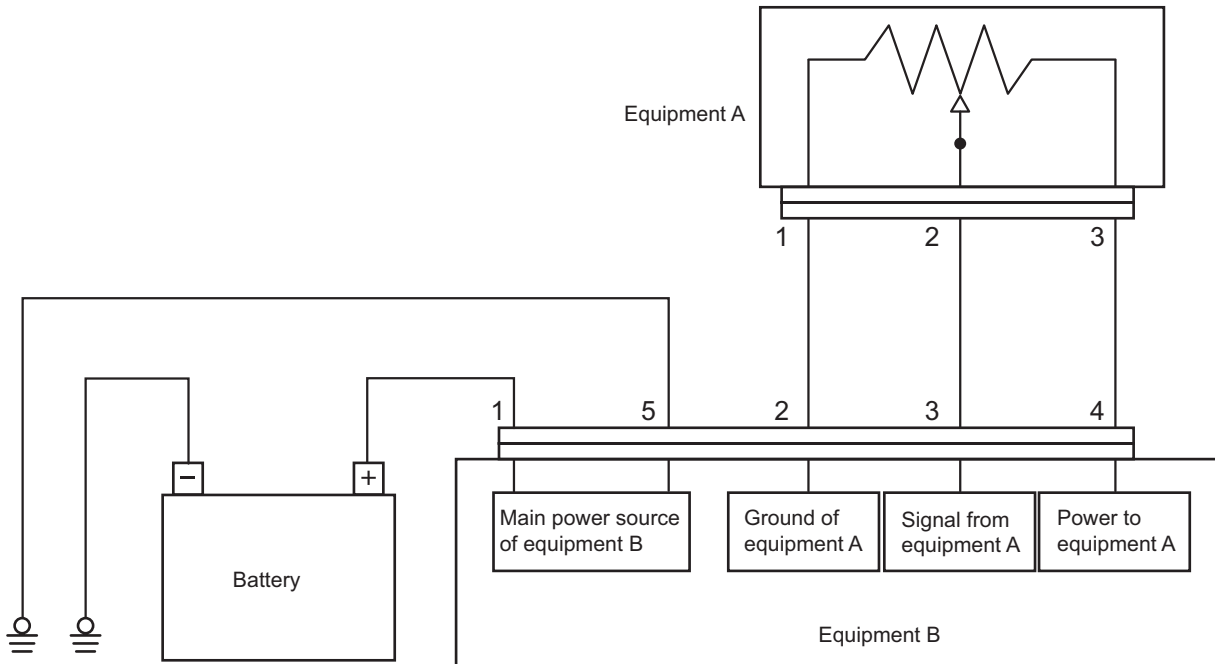

GW750-2-10003

1) Measuring resistance using tester

1-1) Measuring resistance of equipment A (measuring resistance between terminals 1 and 3)

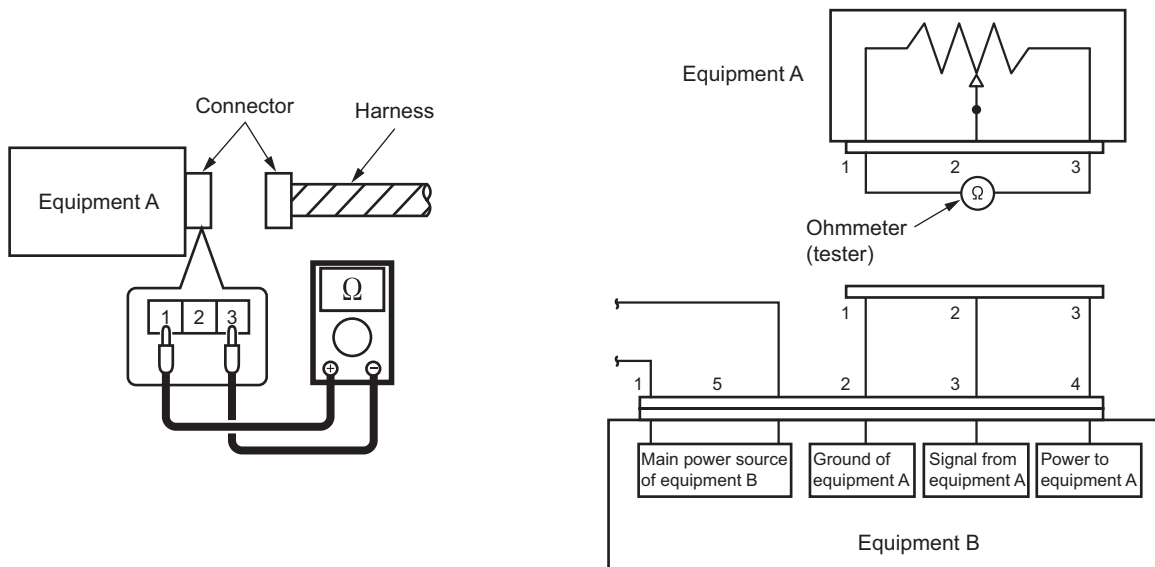

GW750-2-10004

Inspection procedure

- ① Disconnect the connector of equipment A.
- ② Connect the test probe (+) to connector terminal 1 of equipment A and the test probe (-) to connector terminal 3 of equipment A and measure the resistance. At this time, reversing the connector terminals between the probes (+) and (-) does not make any difference in the measurement.

- 1-2) Measuring resistance of harness (measuring resistance between terminal 1 of equipment A and terminal 2 of equipment B)

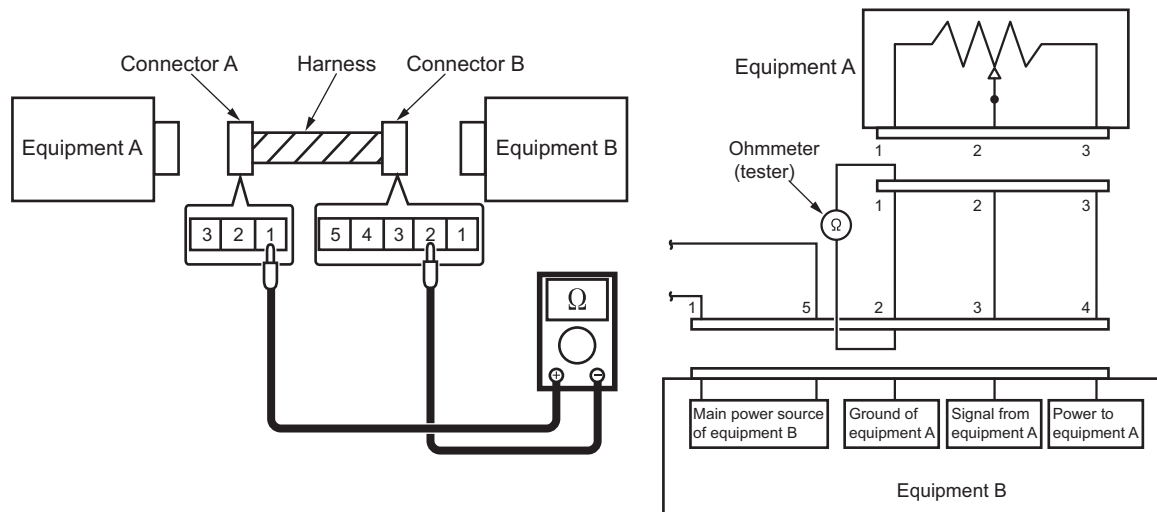

GW750-2-10005

Inspection procedure

- ① Disconnect the connectors of equipment A and equipment B.
- ② Connect the test probe (+) to connector terminal 1 of equipment A and the test probe (-) to connector terminal 2 of equipment B and measure the resistance. At this time, reversing the connector terminals between the probes (+) and (-) does not make any difference in the measurement.

Criteria for harness defects

When there is no abnormality in the harness: Less than 10 Ω (measured value)

If there is any abnormality in the harness such as broken wire: 10 Ω or higher (measured value)

- 1-3) Measuring resistance of grounding wire (measuring resistance between terminal 5 of equipment B and ground)

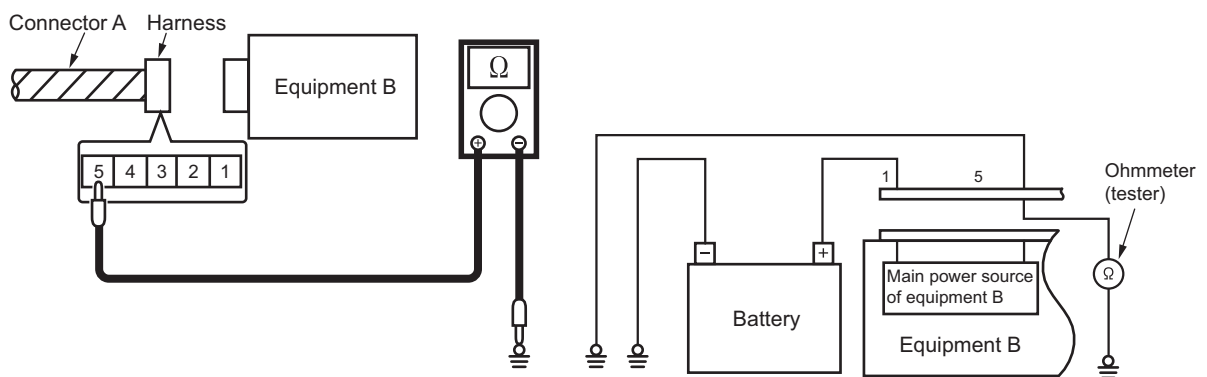

GW750-2-10006

Inspection procedure

- ① Disconnect the connector of equipment B.
- ② Connect the test probe (+) to connector terminal 5 of equipment B and the test probe (-) to a machine ground point (the bolt fastening the ground terminal or an unpainted portion on the body) and measure the resistance. At this time, reversing the connector terminals between the probes (+) and (-) does not make any difference in the measurement.

(NOTICE)

- When measuring the resistance, connect the test probes to both ends of the portion to be measured. Make also sure that no voltage is applied to the portion to be measured.
- When measuring the internal resistance of equipment, be sure first to disconnect all harnesses from the equipment.
- When measuring the resistance of a harness, disconnect the equipment connected to both ends of the harness.

TROUBLESHOOTING

2) Measuring voltage and current flowing using tester

2-1) Measuring voltage of equipment A (measuring voltage between terminals 1 and 3)

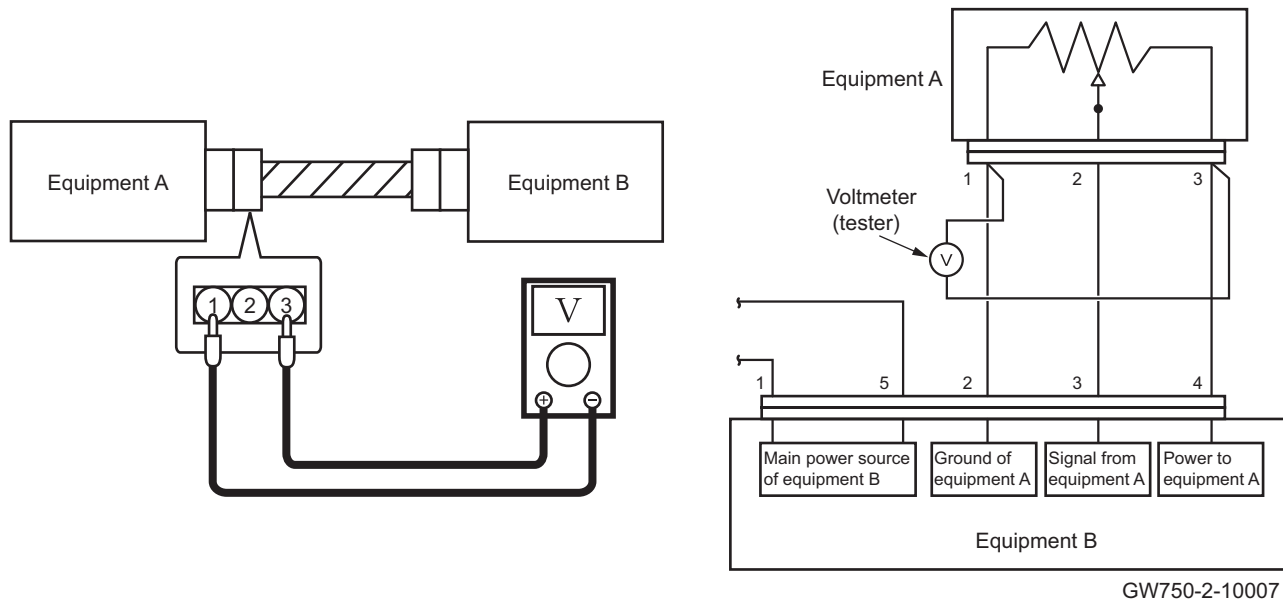

Inspection procedure

- ① Connect the connectors of equipment A and that of equipment B.
- ② Connect the test probe (+) to connector terminal 3 of equipment A and the test probe (-) to connector terminal 1 of equipment A and measure the voltage. Note that reversing the connector terminals between the probes (+) and (-) changes the result of the measurement. Be sure to connect the probe (+) to the power source side and the probe (-) to the ground side.

- Measurement using a test harness

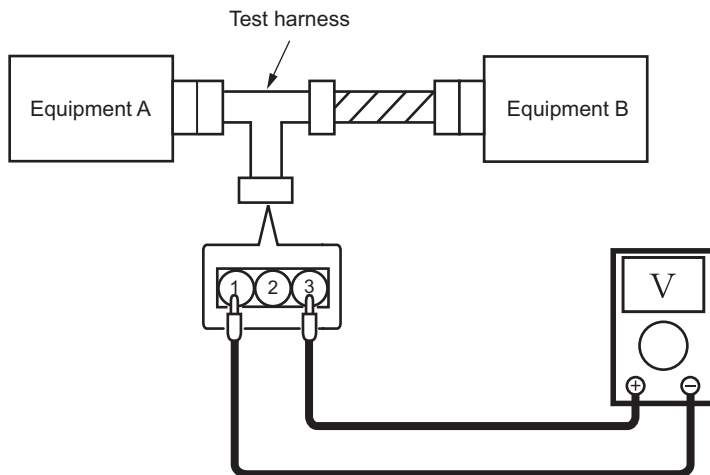

- Measurement from the backside of connector

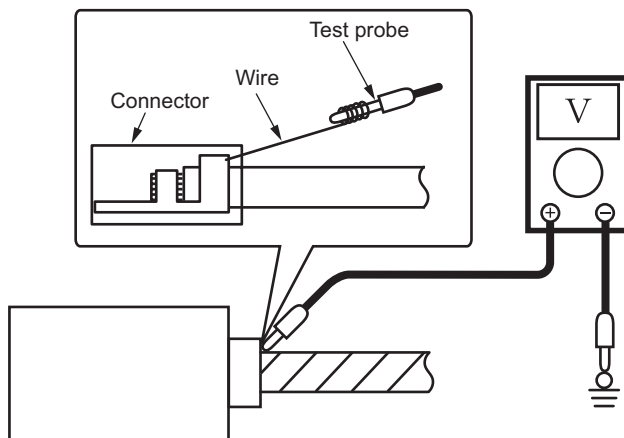

- Measurement on a lead cable

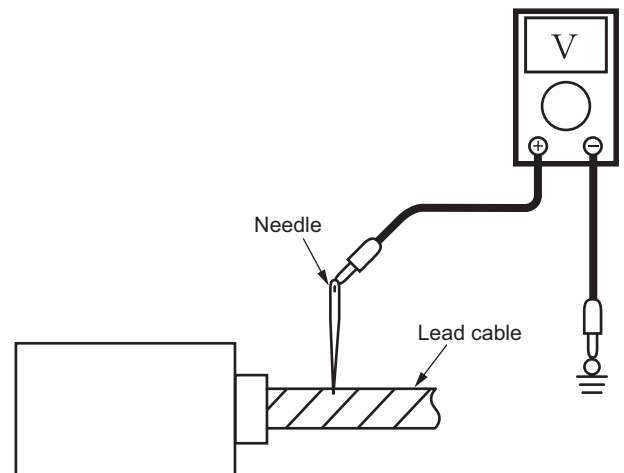

GW750-2-10002

Measurement method

For measurement of voltage, connect the tester probes in parallel to the portion to be measured. Because the voltage can be measured only when the connector is connected in position, contact the tester probes to the terminals without disconnecting the connector. The following methods are available:

- Measurement using a test harness
 - Prepare the test harness for the measurement.
- Measurement from the backside of connector
 - Insert a wire from the backside of the connector.
- Measurement on a lead cable
 - Remove the bundling tape from the harness to separate each cable, and stick the needle into the relevant cable.

(NOTICE)

- Except for preparing the test harness, proper protection must be made after the measurement to prevent corrosion in the connector terminals or harnesses.

- 2-2) Measuring current flowing from equipment B to equipment A
 (measuring current between terminal 2 of equipment B and terminal 1 of equipment A)

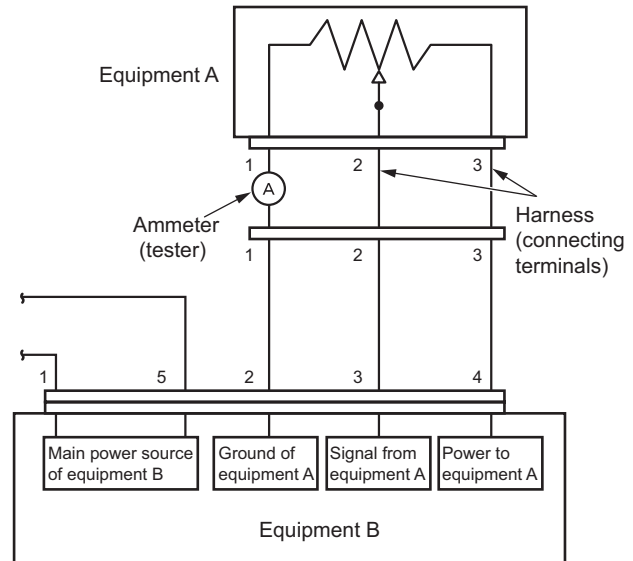
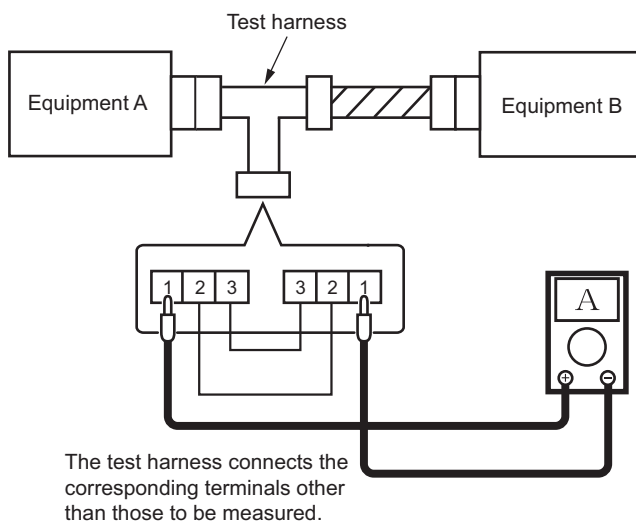

GW750-2-10008

Inspection procedure

- ① Disconnect the connector of equipment A and connect the test harness.
- ② Connect the test probe (+) to connector terminal 1 (harness side) of equipment A and the test probe (-) to connector terminal 1 (equipment side) of equipment A and measure the current. Note that reversing the connector terminals between the probes (+) and (-) changes the result of the measurement. Be sure to connect the probe (+) to the power source side and the probe (-) to the ground side.

Measurement method

When measuring the current, connect the tester in series to the portion to be measured. Because the current cannot be measured when the connector is connected in position, disconnect the connector to allow the test probe to connect between the terminals.

2-1-3. Inspection of electrical system

Operate the applicable switches and turn the relays ON and OFF. Ultimately, if the solenoid valve operates (makes a sound) and the pump runs, the electrical system is OK.

If there is a failure (fault), narrow the range of the inspection to the six broad steps described below.

1) Ground inspection

- Check for disconnected or loose ground. If rust or corrosion is present (which can cause faulty contact), remove the rust.

2) Fuse inspection

2-1) Check for blown fuses, disconnections and corrosion. (A fatigue open circuit cannot be identified visually. Use a tester for checking.)

2-2) If a fuse is blown

Check whether a pump or valve (that is supposed to be protected by a blown fuse) burned, and whether there is a burning odor.

Especially if the pump and valve are not burned, check the harness for signs of burning. If it is burned, replace it.

If a fuse is blown and a relay along the pathway has failed, replace it. And if there is a timer, replace the timer, too. If a switch visually appears to be unsatisfactory (burned, melted, etc.) even though it operates, replace it.

- Simply replacing a fuse may not eliminate the true cause of a problem, and over current may flow again. Also, if over current secondarily causes an electrical path to fail (such as a wiring meltdown inside a solenoid valve), current will not flow. Thus, a fuse may not be blown out, but it also will not operate. If you do not know the location of burning or of an odor, investigate as described follows.

2-3) How to find cause of failure when fuse blown is reproduced

- ① Turn the starter switch OFF, and remove the connector from the load (valve, pump).
- ② Referring to the circuit diagram, remove electrical parts that are connected to the circuit, such as relays, timers and diodes.
- ③ Turn the starter switch ON, and see whether the conditions can be reproduced (fuse is blown).
- ④ If a fuse is blown, a part such as a relay may have caused a short between the previous harness and ground (vehicle body). (Replace the harness.) If the conditions are not reproduced, check for signs of burning (odor) on the removed electrical parts.
- ⑤ If there is no problem, turn the starter switch OFF and reattach the parts.
- ⑥ Turn the starter switch ON and try again.
- ⑦ If a fuse is blown with this action, the problem was caused by a short between the harness and ground (vehicle body) that followed the attached electrical part. (Replace the harness.)
- ⑧ If the conditions are not reproduced, turn the starter switch OFF, and connect the loads (valve and pump) one at a time. Turn the starter switch ON and try again to see whether the fuse blown is reproduced.
- ⑨ If the fuse blown is reproduced, whatever was added at that time (including a harness added electrically) will be the cause of the failure.
 - Even if the fuse is not blown and the valve or pump is not burned, the valve or pump may be damaged electrically and may not operate. There may simply be a disconnection in the interior or an abnormal heat-up.
 - Even if the fuse is not blown, abnormal heat-up (hot enough to cause burns if touched) may occur if a relay, timer, diode or other semiconductor fails.

3) Connector inspection

- Is a connector disconnected or loose?
- Check that pins are not snapped or corroded.
- If faulty contact is suspected

Turn the starter switch OFF. Then disconnect and check the connectors (including relay and switch sockets).

If the terminal has no luster, faulty contact due to oxidation can be suspected. Therefore, polish the terminal by inserting and removing the connector (relay, switch) repeatedly at least five times. (Luster will return.)

4) Relay inspection (Check ON/OFF operation by sound.)

- Conduct without running the engine. (If you run the engine, you cannot hear the sound of operation.)

Sound heard : A relay failure occurred.

No sound heard : Using a tester, check the harness.

Sound heard : A relay failure occurred.

Still no sound : Using a tester, check the harness.

Continuity : Turn the starter switch OFF temporarily, disconnect the relay and check for continuity between the harness-side grounding terminal (color: black) and vehicle body ground. (If there is none, replace the harness.)

Voltage : With the relay disconnected, turn the starter switch ON and turn the operating switch ON. 24 V (or 12 V) (between vehicle body ground) should not reach the relay coil input terminal. Confirm this. Identify the location (section) to which 24 V (or 12 V) reaches. Then replace the harness or take other action.

5) Solenoid valve inspection (Check ON/OFF operation by sound.)

- Conduct without running the engine. (If you run the engine, you cannot hear the sound of operation.)

Sound heard : The electrical system is normal.

No sound heard : Check with a tester.

Continuity : ① Turn the starter switch OFF temporarily, disconnect the connector and check for continuity between the harness-side grounding terminal (color: black) and vehicle body ground. (If there is none, replace the harness.)

: ② Is the solenoid valve coil burnt?

(Turn the starter switch OFF, disconnect the connector and check the resistance between the solenoid valve terminals.)

Voltage : With the connector disconnected, turn the starter switch ON and check whether 24 V (or 12 V) exists between the harness-side connector and vehicle body ground.

If YES : Replace the valve.

If NO : Investigate and identify the location (section) to which 24 V (or 12 V) reaches. Then replace the harness or take other action.

6) Harness check

- If an incomplete disconnection inside the harness is suspected, wiggle (move) the harness during the relay inspection and solenoid valve inspection to see whether the relay (valve) operates incorrectly.
- Check for burned areas of the harness.
- Turn the starter switch OFF, disconnect the connector and check the continuity, referring to the circuit diagram and wiring coloring.

Fig.: 2-2-1

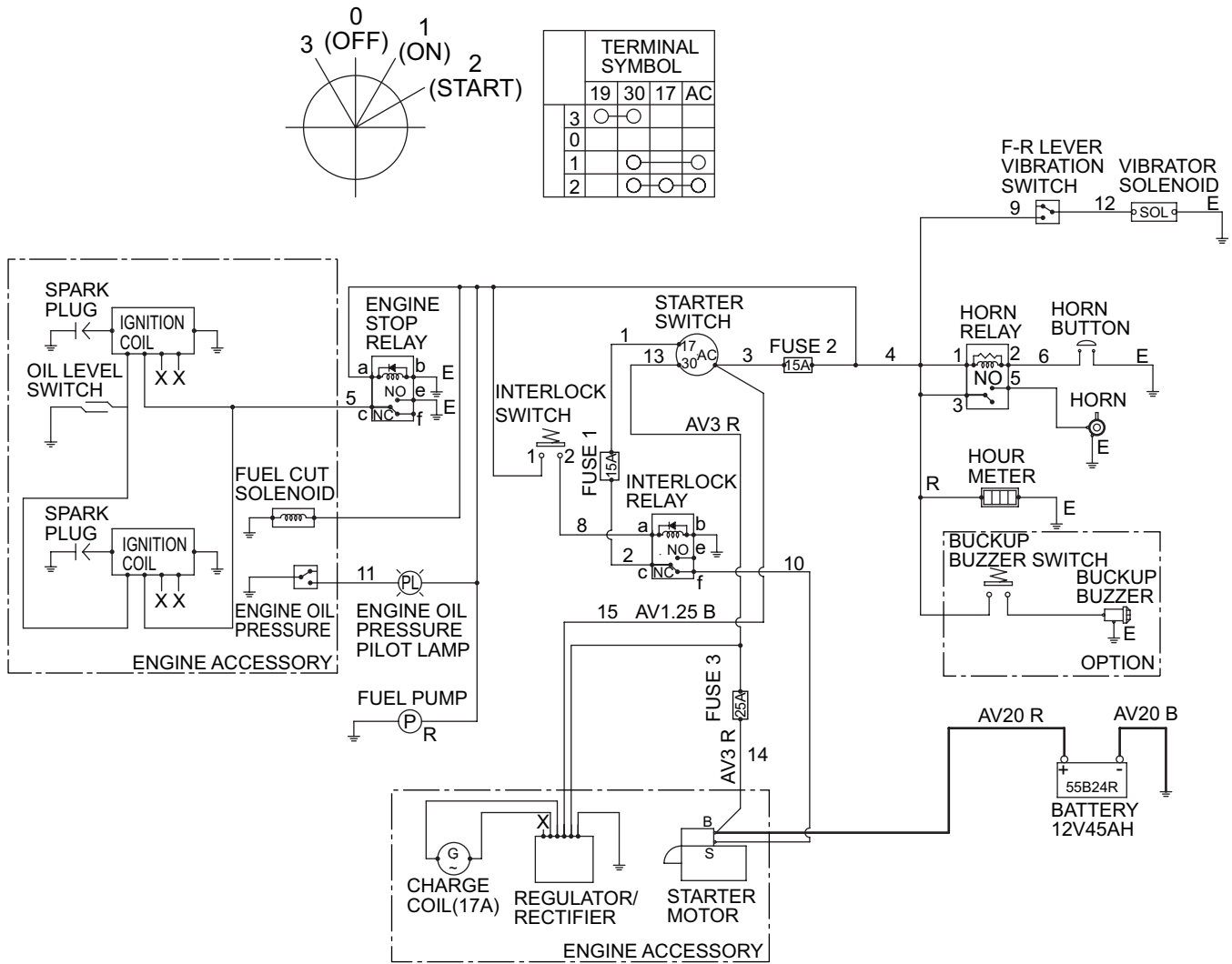

0563-99009-0-20460-0

• The wire size is AV 1.25 unless otherwise specified.

2-2. Engine

Check following items before troubleshooting.

- No blown fuses and power is applied up to fuses.

2-2-1. Engine will not start (Starter motor does not run)

- F-R lever must be "N".

Reference Fig.: 2-2-1

Check point	Check/Cause	Action
1. Battery	<ul style="list-style-type: none"> • Measure battery voltage or specific gravity. Standard voltage : 12 V or more Standard gravity : 1.26 or more • If value is below standard, battery capacity is insufficient. 	Charge or replace battery.
2. Starter Switch	<ul style="list-style-type: none"> • Check continuity between O-O according to starter switch connection table. Switch is OK if there is continuity between connection O-O. • If there is no continuity, starter switch is faulty. 	Replace starter switch.
3. Starter Motor	<ul style="list-style-type: none"> (1) Measure voltage between starter motor terminal B and chassis ground. Standard voltage : 12 V or more (2) When starter switch is START, measure voltage between starter motor terminal S and chassis ground. Standard voltage : 12 V or more • If starter motor does not run even though above items (1) and (2) are OK, starter motor is faulty. 	Replace starter motor.
4. Interlock Switch	<ul style="list-style-type: none"> • When starter switch is ON, measure voltage between interlock switch terminal 2 and chassis ground. There is no electricity in normal condition. • If electricity flows, interlock switch is faulty. 	Replace interlock switch.
5. Interlock Relay	<ul style="list-style-type: none"> (1) When starter switch is ON, measure voltage between interlock relay terminal b and chassis ground. There is no electricity in normal condition. (2) When starter switch is START, measure voltage between interlock relay terminal f and chassis ground. Standard voltage : 12 V or more • If above item (1) is OK and item (2) is NG, interlock relay is faulty. 	Replace interlock relay.
6. Harness Connecting Between Terminals	<ul style="list-style-type: none"> • Measure resistance of harness connecting between terminals. Standard resistance : 10 Ω or less • If resistance is abnormal, harness is faulty. 	Repair or replace harness.

Fig.: 2-2-1

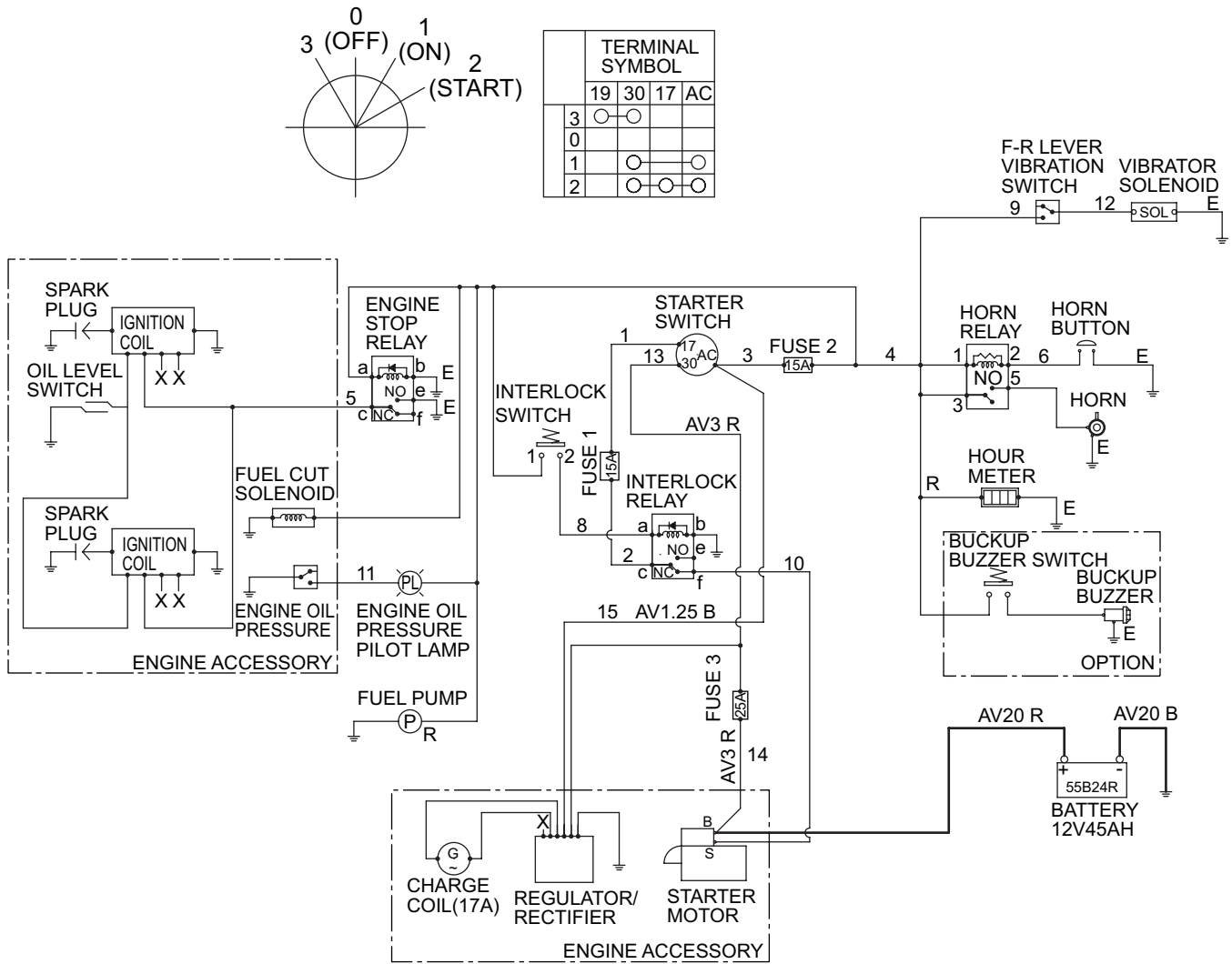

0563-99009-0-20460-0

• The wire size is AV 1.25 unless otherwise specified.

2-2-2. Engine will not start (But starter motor runs)

- In case of engine will not start while starter motor runs, generally trouble is caused by that fuel is not supplied, supply amount of fuel is extremely low, or selection of fuel is not appropriate.
- Check that fuel is supplied to inlet of fuel pump.

Reference Fig.: 2-2-1

Check point	Check/Cause	Action
1. Fuel Pump	<ul style="list-style-type: none"> • When starter switch is ON, measure voltage between fuel pump terminal wire R and chassis ground. Standard voltage : 12 V or more • If voltage is OK and engine will not start, fuel pump is faulty. 	Replace fuel pump.
2. Fuel Cut Solenoid	<ul style="list-style-type: none"> • When starter switch is ON, measure voltage between fuel cut solenoid terminal wire marked [FUEL CUT] and chassis ground. Standard voltage : 12 V or more • If voltage is OK and engine will not start, fuel cut solenoid is faulty. 	Replace fuel cut solenoid.
3. Engine Stop Relay	<p>(1) When starter switch is ON, measure voltage between engine stop relay terminal b and chassis ground. Standard voltage : 12 V or more</p> <p>(2) When starter switch is ON, check continuity between engine stop relay terminal c and terminal e. There is continuity in normal condition.</p> <ul style="list-style-type: none"> • If above item (1) is OK and item (2) is NG, engine stop relay is faulty. 	Replace engine stop relay.
4. Harness Connecting Between Terminals	<ul style="list-style-type: none"> • Measure resistance of harness connecting between terminals. Standard resistance : 10 Ω or less • If resistance is abnormal, harness is faulty. 	Repair or replace harness.

Fig.: 2-2-1

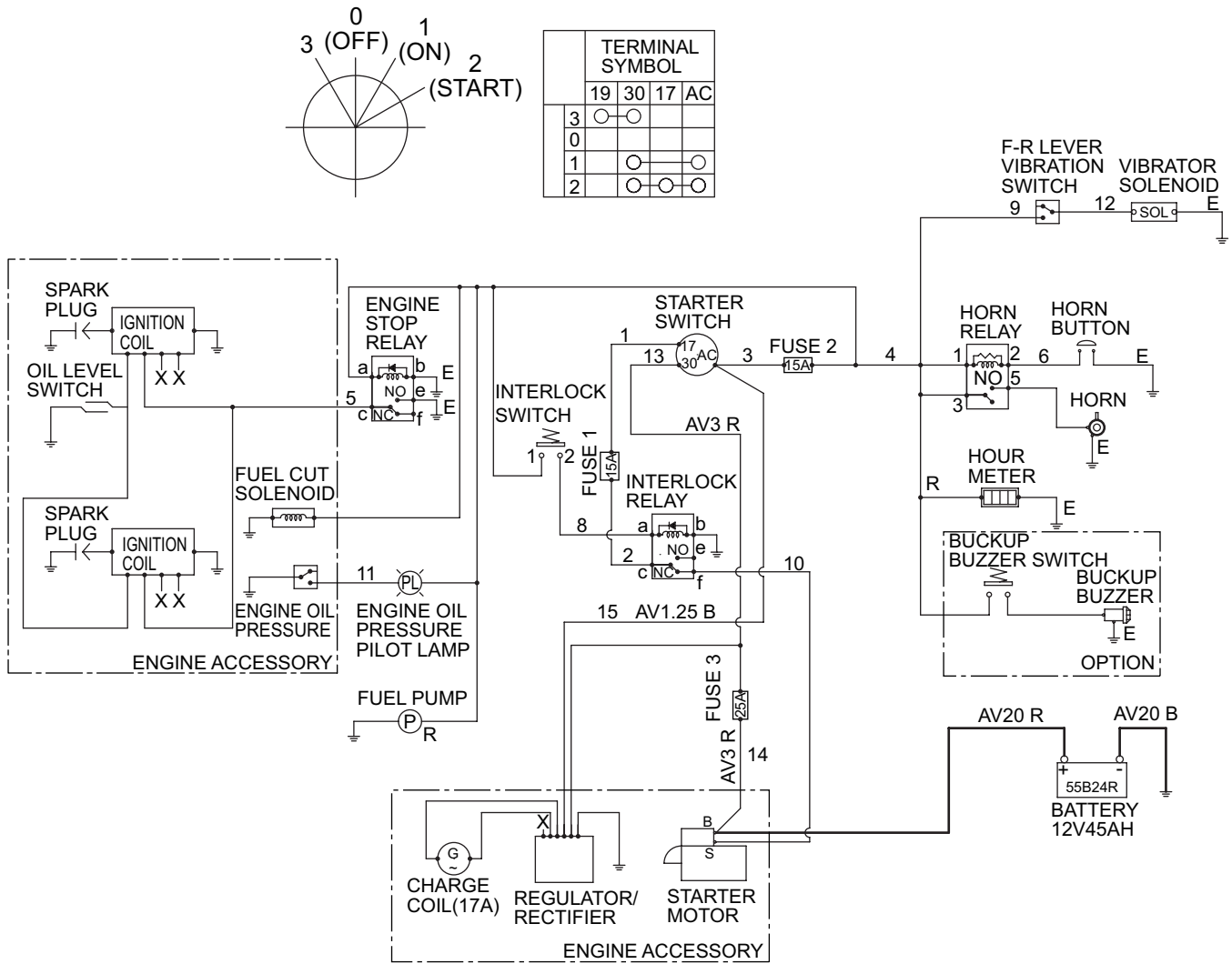

TERMINAL SYMBOL	
19	30 17 AC
3	○ ○
0	
1	○ ○ ○ ○
2	○ ○ ○ ○

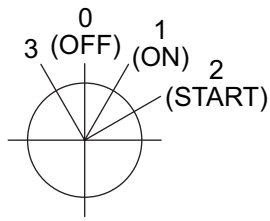

0563-99009-0-20460-0

• The wire size is AV 1.25 unless otherwise specified.

2-2-3. No charging

Reference Fig.: 2-2-1

Check point	Check/Cause	Action
1. Regulator/Rectifier	<ul style="list-style-type: none"> • After starting engine, measure voltage between battery terminals. Standard voltage : At least intermediate engine speed, 13.5 ~ 14.5 V. • If voltage is higher or lower than standard, regulator/rectifier is faulty. For details, refer to Shop Manual of engine manufacturer. • If voltage is normal and battery is not charged, battery is faulty. 	Replace regulator/rectifier or battery.

2-2-4. Starter motor runs even when F-R lever is not at “N” applied

Reference Fig.: 2-2-1

Check point	Check/Cause	Action
1. Interlock Switch	<ul style="list-style-type: none"> • When starter switch is OFF and F-R lever is “N”, check continuity between interlock switch terminal 1 and terminal 2. There is no continuity in normal condition. • If there is continuity, interlock switch is faulty. 	Replace interlock switch.
2. Interlock Relay	<p>(1) When starter switch is ON and F-R lever is “F” or “R”, measure voltage between interlock relay terminal b and chassis ground. Standard voltage : 12 V or more</p> <p>(2) When starter switch is START, measure voltage between interlock relay terminal f and chassis ground. There is no electricity in normal condition.</p> <ul style="list-style-type: none"> • If above item (1) is OK and item (2) is NG, interlock relay is faulty. 	Replace interlock relay.

Fig.: 2-2-1

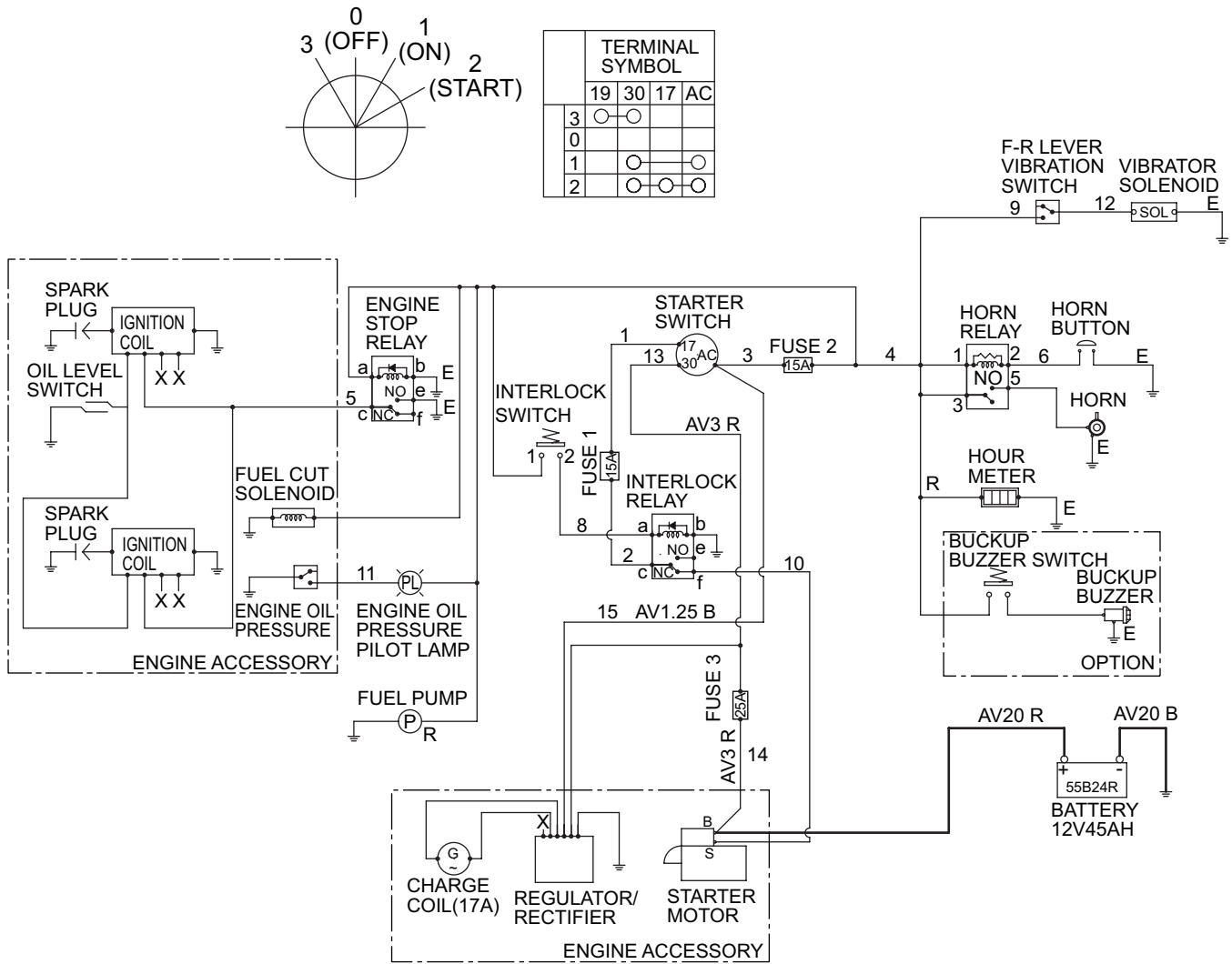

0563-99009-0-20460-0

• The wire size is AV 1.25 unless otherwise specified.

2-3. Propulsion

Check following items before troubleshooting.

- No blown fuses and power is applied up to fuses.

2-3-1. Hour meter is abnormal

Reference Fig.: 2-2-1

Check point	Check/Cause	Action
1. Hour meter	(1) When starter switch is ON, measure voltage between hour meter wire R and chassis ground. Standard voltage : 12 V or more (2) Check that hour meter wire E is reliably grounded. • If items (1) and (2) are OK and hour meter does not work, hour meter is faulty.	Replace hour meter.

2-3-2. Horn does not sound

Reference Fig. : 2-2-1

Check point	Check/Cause	Action
1. Horn	<ul style="list-style-type: none"> • Disconnect horn and directly connect battery positive terminal to horn terminal wire marked HORN and negative terminal to horn terminal wire E side. • If horn does not sound, horn is faulty. 	Replace horn.
2. Horn Relay	(1) When starter switch is ON and horn switch is pressed, measure voltage between horn relay terminal 2 and chassis ground. Standard voltage : 12 V or more (2) When starter switch is ON and horn switch is pressed, measure voltage between horn relay terminal 5 and chassis ground. Standard voltage : 12 V or more • If above item (1) is OK and item (2) is NG, horn relay is faulty.	Replace horn relay.
3. Horn Switch	<ul style="list-style-type: none"> • When horn switch is OFF, measure resistance between horn switch terminals. Standard resistance : 100 kΩ or more • If resistance is abnormal, horn switch is faulty. 	Replace horn switch.
4. Harness Connecting Between Terminals	<ul style="list-style-type: none"> • Measure resistance of harness connecting between terminals. Standard resistance : 10 Ω or less • If resistance is abnormal, harness is faulty. 	Repair or replace harness.

Fig.: 2-2-1

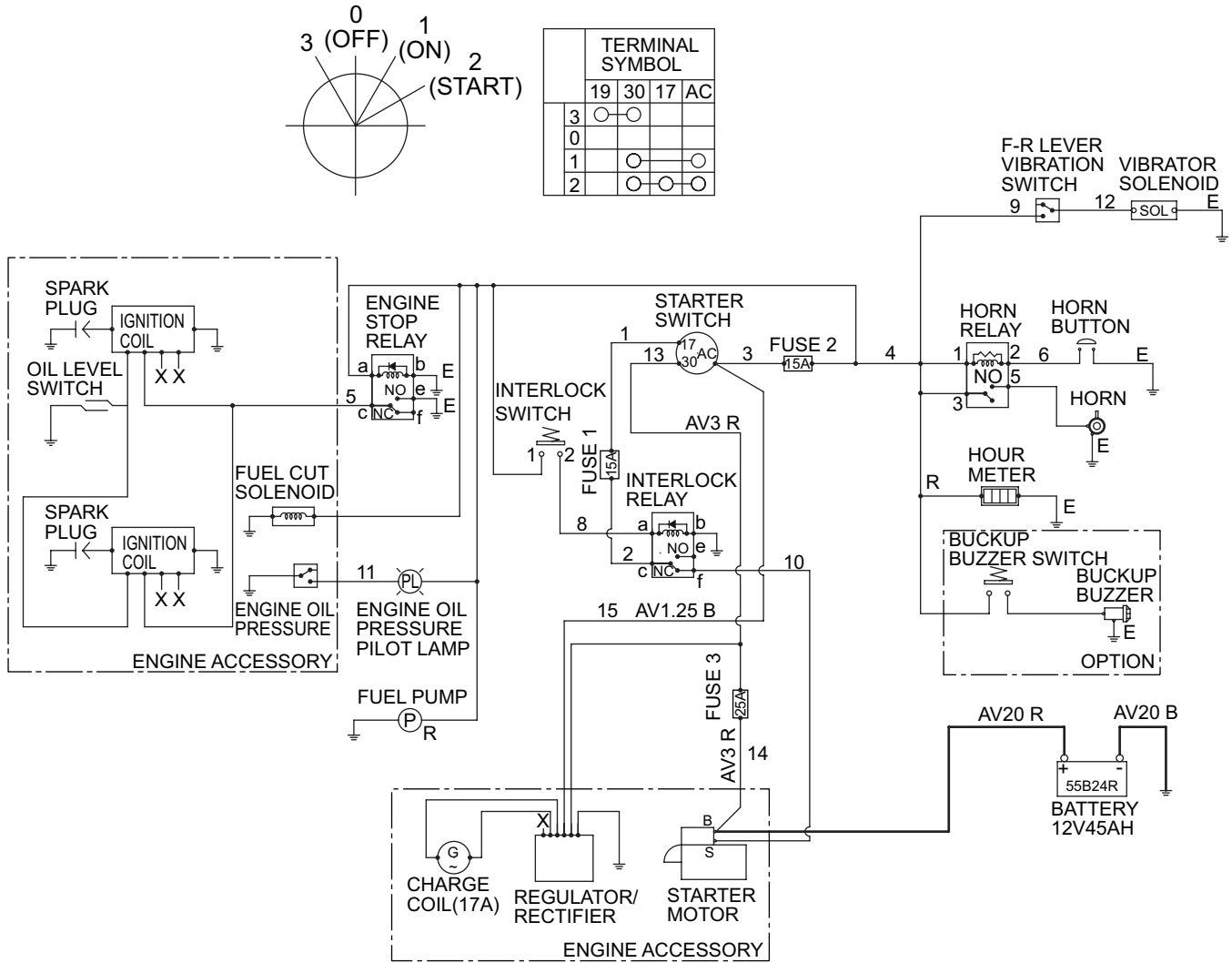

0563-99009-0-20460-0

• The wire size is AV 1.25 unless otherwise specified.

2-4. Vibration

Check following items before troubleshooting.

- No blown fuses and power is applied up to fuses.
- Throttle lever must be "FULL".

2-4-1. No vibration occurs

Reference Fig.: 2-2-1

Check point	Check/Cause	Action
1. Vibrator Solenoid	<ul style="list-style-type: none"> • Disconnect harness and measure resistance of coil. Standard resistance : 4.7 Ω • If resistance is abnormal, vibrator solenoid is faulty. 	Replace vibrator solenoid.
2. F-R Lever Vibration Switch	<p>(1) When starter switch is ON, measure voltage between F-R lever vibration switch terminal wire marked VIB-SW1-1 and chassis ground. Standard voltage : 12 V or more</p> <p>(2) When starter switch is ON and F-R lever vibration switch is pressed once, measure voltage between F-R lever vibration switch terminal wire marked VIB-SW1-2 and chassis ground. Standard voltage : 12 V or more</p> <ul style="list-style-type: none"> • If above item (1) is OK and item (2) is NG, F-R lever vibration switch is faulty. 	Replace F-R lever vibration switch.
3. Harness Connecting Between Terminal	<ul style="list-style-type: none"> • Measure resistance of harness connecting between terminals. Standard resistance : 10 Ω or less • If resistance is abnormal, harness is faulty. 	Repair or replace harness.

3. HYDRAULIC SYSTEM TROUBLESHOOTING

3-1. When Performing Hydraulic System Troubleshooting

- The largest factor in the majority of failures of hydraulic devices operating under conditions of higher pressure and greater precision is the entry of dirt (foreign substances) into the hydraulic circuit. Particular caution is required when supplying hydraulic oil or when disassembling and assembling hydraulic devices.

1) Pay attention to the work environment.

As much as possible, avoid performing tasks such as supplying hydraulic oil, replacing filters and repair work on rainy days, when there is strong wind, or in locations where there is much dust.

2) Disassembly and maintenance work in the field

There is the danger of dust entry when disassembly and maintenance work for hydraulic components is performed in the field. In addition, because performance verification after repairs are completed is difficult, replacement of the entire assembly is preferred. Perform disassembly and maintenance of hydraulic components in a special room protected from dust, and use special testers to verify the performance.

3) Sealing of openings

Use caps, tape, plastic bags or other means to seal the openings of removed pipes and components in order to prevent foreign substances from entering. Never leave the openings exposed or put a shop cloth into them. There is the danger of foreign substances entering or of leaking oil causing environmental contamination.

Do not dispose of waste oil on-site. Either deliver it to the customer and request disposal or take it back with you and dispose of it.

4) Prevent entry of foreign substances when supplying oil.

Take care that foreign substances do not enter when supplying hydraulic oil. Clean the oil supply port and the area around it, as well as the supply pump, oilcan and other items. A more reliable method is to use oil cleaning equipment, which can filter out the contamination that occurred during storage.

5) Change hydraulic oil while the temperature is still high.

All oils, including hydraulic oil, flow more readily when they are warm. Higher temperatures also make it easier to eject the sludge and other substances outside the circuit together with the oil. For these reasons, oil changes should be performed while the oil temperature is high. When changing the oil, it is necessary to drain out as much of the old hydraulic oil as possible. (In addition to the hydraulic oil tank, also drain the oil from the filter and circuit drain plugs.) If old hydraulic oil remains in the system, the contaminants and sludge in the old oil will mix with the new oil and shorten the hydraulic oil lifetime.

3-2. Propulsion System

If a problem occurs in the propulsion systems such as the propulsion pump, propulsion motor and brakes, determine the cause and carry out action as required, according to the following general troubleshooting items.

(NOTICE)

- When checking whether or not the pressure is correct, refer to the pressure standard value for each hydraulic circuit.

3-2-1. Machine moves neither forward nor backward

Check point	Cause	Check/Action
1. Oil Level of Hydraulic Oil Tank	Oil level in hydraulic oil tank is low.	Fill tank until correct oil level is obtained.
2. Bypass Valve	Bypass valve is open.	Close bypass valve.
3. F-R Lever Linkage	F-R lever linkage is faulty.	Check and adjust F-R lever linkage or replace it if necessary.
4. Charge Circuit Pressure	Propulsion pump does not discharge oil because charge pressure is low.	<ul style="list-style-type: none"> • Measure charge pressure. • If low, inspect charge relief valve or replace it if necessary.
	Insufficient charge pump discharge.	Repair charge pump or replace it if necessary.
5. Suction Filter for Charge Pump	Charge pump flow is reduced due to clogged filter.	Clean suction filter or replace it if necessary.
6. Propulsion Circuit Pressure	Circuit does not obtain required pressure because setting pressure of high pressure relief is low.	<ul style="list-style-type: none"> • Measure propulsion circuit pressure. • If low, inspect high pressure relief valve or replace it if necessary.
7. Propulsion Motor	Propulsion circuit pressure is not held in propulsion motor case.	If pressure in propulsion motor case is not within allowable range, repair propulsion motor or replace it if necessary.
	Internal leakage of propulsion motor.	<ul style="list-style-type: none"> • Measure drain quantity from propulsion motor. • If drain quantity is larger than standard value, repair propulsion motor or replace it if necessary.
8. Propulsion Pump	Discharge flow rate is insufficient due to efficiency degradation of propulsion pump.	<ul style="list-style-type: none"> • Measure discharge flow rate of propulsion pump with flow meter. • If discharge flow rate is not within specified range, repair propulsion pump or replace it if necessary.
	Discharge flow rate is insufficient due to wear of propulsion pump drive shaft splines.	Replace propulsion pump.
	Propulsion circuit pressure is not held in propulsion pump case.	If pressure in propulsion pump case is not within allowable range, repair propulsion pump or replace it if necessary.
9. Coupling	Drive torque is not transmitted to pump due to faulty coupling.	Replace coupling.

3-2-2. Machine moves in one direction only (forward or backward)

Check point	Cause	Check/Action
1. F-R Lever Linkage	F-R lever linkage is faulty.	Check and adjust F-R lever linkage or replace it if necessary.
2. High Pressure Relief Valve	Low circuit pressure due to incorrect high pressure relief setting or internal leakage of high pressure valve.	<ul style="list-style-type: none"> • Interchange two multifunction valves. • If faulty condition is accordingly reversed, inspect high pressure relief valve or replace it if necessary.

3-2-3. Slow machine speed or small drive force

Check point	Cause	Check/Action
1. Bypass Valve	Bypass valve is slightly open.	Close bypass valve completely.
2. F-R Lever Linkage	F-R lever linkage is faulty.	Check and adjust F-R lever linkage or replace it if necessary.
3. Charge Circuit Pressure	Stroke of propulsion pump swash plate is small because charge pressure is low, decreasing discharge rate of propulsion pump.	<ul style="list-style-type: none"> • Measure charge pressure. • If low, inspect charge relief valve or replace it if necessary.
	Insufficient charge pump discharge.	Repair charge pump or replace it if necessary.
4. Suction Filter for Charge Pump	Flow rate of charge pump decreases as well as charge pressure decreases due to clogged filter.	Clean suction filter or replace it if necessary.
5. Propulsion Motor	Propulsion motor inlet pressure is low.	<ul style="list-style-type: none"> • Measure propulsion motor inlet pressure. • If low, inspect high pressure relief valve or replace it if necessary.
	Propulsion circuit pressure is not held in propulsion motor case.	If pressure in propulsion motor case is not within allowable range, repair propulsion motor or replace it if necessary.
	Output of propulsion motor decreases and number of revolutions decreases due to internal leakage of propulsion motor.	<ul style="list-style-type: none"> • Measure drain quantity from propulsion motor. • If drain quantity is larger than standard value, repair propulsion motor or replace it if necessary.
6. Propulsion Pump	Discharge flow rate is insufficient due to efficiency degradation of propulsion pump.	<ul style="list-style-type: none"> • Measure discharge flow rate of propulsion pump with flow meter. • If discharge flow rate is not within specified range, repair propulsion pump or replace it if necessary.
	Discharge flow rate is insufficient due to wear of propulsion pump drive shaft splines.	Replace propulsion pump.
	Propulsion circuit pressure is not held in propulsion pump case.	If pressure in propulsion pump case is not within allowable range, repair propulsion pump or replace it if necessary.

3-2-4. Machine does not stop completely with F-R lever in “N”

Check point	Cause	Check/Action
1. F-R lever Linkage	F-R lever linkage is faulty.	Check and adjust F-R lever linkage or replace it if necessary.
2. Swash Plate	Faulty pump swash plate setting.	Repair propulsion pump or replace it if necessary.

3-2-5. Propulsion system is overheating

Check point	Cause	Check/Action
1. Oil Level of Hydraulic Oil Tank	Oil level in hydraulic oil tank is low.	Fill tank until correct oil level is obtained.
2. Propulsion Circuit Pressure	If circuit pressure setting is excessively low, relief valve opens, causing temperature of hydraulic oil in circuit to rise.	<ul style="list-style-type: none"> • Measure propulsion circuit pressure. • If low, inspect relief valve or replace it if necessary.
	If load is excessively heavy, relief valve opens, causing temperature of hydraulic oil in circuit to rise.	<ul style="list-style-type: none"> • Measure propulsion circuit pressure. • If high, decrease propulsion load.
3. Suction Filter for Charge Pump	Load of charge pump increases due to clogged filter, causing temperature of hydraulic oil in circuit to rise.	Clean suction filter or replace it if necessary.

3-2-6. Abnormal noise from propulsion system

Check point	Cause	Check/Action
1. Axle Bearings	Axle bearings supporting front and rear drums are damaged.	Replace axle bearings.
2. Hydraulic Hose Clamp	Vibrator sound of hydraulic hose is generated because clamp securing hydraulic hose is loose.	Tighten bolts of loose hydraulic hose clamp to specified torque.
3. Suction Filter for Charge Pump	Cavitation is occurring in charge pump due to clogged filter.	Clean suction filter or replace it if necessary.
4. Parking Brake Lever	Brake cannot be released completely, which causes brake drag.	<ul style="list-style-type: none"> • Inspect brake cable, pads or disk or replace them if necessary.
5. Propulsion Motor	Internal bearing of propulsion motor is damaged.	Repair propulsion motor or replace it if necessary.

3-3. Steering System

If a problem occurs in the steering systems such as the steering pump and orbitrol, determine the cause and carry out action as required, according to the following general troubleshooting items.

(NOTICE)

- When checking whether or not the pressure is correct, refer to the pressure standard value for each hydraulic circuit.

3-3-1. Steering wheel is hard to turn

Check point	Cause	Check/Action
1. Oil Level of Hydraulic Oil Tank	Oil level in hydraulic oil tank is low.	Fill tank until correct oil level is obtained.
2. Orbitrol	Relief valve is open or setting pressure is low.	<ul style="list-style-type: none"> • Measure steering circuit pressure. • If low, check and adjust relief valve or replace it if necessary.
	Flow to steering cylinder circuit is insufficient due to leakage from check valve.	Check and clean check valve or replace it if necessary.
	Spool and sleeve of orbitrol are contaminated or clearance is incorrect.	Check and clean orbitrol or replace it if necessary.
3. Steering Circuit Pressure	Pressure in return circuit from orbitrol increases due to clogged charging hydraulic oil filter.	Clean hydraulic oil filter or replace it if necessary.
4. Steering Cylinder	Cylinder thrust decreases due to internal leakage of steering cylinder.	Repair steering cylinder or replace it if necessary.
5. Suction Filter for Steering • Vibrator • Charge Pump	Charge pump discharge rate decreases due to clogged filter.	Clean suction filter or replace it if necessary.
6. Steering • Vibrator • Charge Pump	Discharging pressure is insufficient due to efficiency degradation of charge pump.	<ul style="list-style-type: none"> • Measure steering circuit pressure. • If low, replace charge pump.

3-3-2. Steering response is slow

Check point	Cause	Check/Action
1. Oil Level of Hydraulic Oil Tank	Oil level in hydraulic oil tank is low.	Fill tank until correct oil level is obtained.
2. Orbitrol	Oil is bypassing because relief valve is open.	<ul style="list-style-type: none"> • Measure steering circuit pressure. • If low, check and adjust relief valve or replace it if necessary.
3. Steering Cylinder	Internal leakage of steering cylinder.	Repair steering cylinder or replace it if necessary.
4. Suction Filter for Steering • Vibrator • Charge Pump	Charge pump discharge rate decreases due to clogged filter.	Clean suction filter or replace it if necessary.
5. Steering • Vibrator • Charge Pump	Discharging pressure is insufficient due to efficiency degradation of charge pump.	<ul style="list-style-type: none"> • Measure steering circuit pressure. • If low, replace charge pump.

3-3-3. Steering wheel backlash or play is large

Check point	Cause	Check/Action
1. Orbitrol	Spline of orbitrol is worn.	Replace orbitrol.
2. Steering Wheel	Serration (spline) of wheel is worn.	Replace wheel.

3-3-4. Steering system is overheating

Check point	Cause	Check/Action
1. Oil Level of Hydraulic Oil Tank	Oil level in hydraulic oil tank is low.	Fill tank until correct oil level is obtained.
2. Steering Circuit Pressure	If circuit pressure setting is excessively low, relief valve is open, causing temperature of hydraulic oil in circuit to rise.	<ul style="list-style-type: none"> • Measure steering circuit pressure. • If low, check and adjust relief valve or replace it if necessary.
	If load is excessively heavy, relief valve is open, causing temperature of hydraulic oil in circuit to rise.	<ul style="list-style-type: none"> • Measure steering circuit pressure. • If high, decrease steering load.
3. Suction Filter for Steering • Vibrator • Charge Pump	Load of steering pump increases due to clogged filter, causing temperature of hydraulic oil in circuit to rise.	Clean suction filter or replace it if necessary.

3-3-5. Abnormal noise from steering system

Check point	Cause	Check/Action
1. Oil Level of Hydraulic Oil Tank	Pump suction pressure is high because oil level of hydraulic oil tank is low, causing cavitation in steering circuit system.	Fill tank until correct oil level is obtained.
2. Steering Circuit	Cavitation is caused by air in circuit.	Bleed circuit.
3. Hydraulic Hose Clamp	Vibrator sound of hydraulic hose is generated because clamp securing hydraulic hose is loose.	Tighten bolts of loose hydraulic hose clamp to specified torque.
4. Suction Filter for Steering • Vibrator • Charge Pump	Cavitation is occurring in charge pump due to clogged filter.	Clean suction filter or replace it if necessary.

CR271
SHOP MANUAL

SAKAI HEAVY INDUSTRIES, LTD.

Head office: Seiwa Bldg., 4-8, Shibadaimon 1-chome,
Minato-ku, Tokyo, Japan

Telephone: +81-3-3434-3401

Global Service Division: 2500 Takayanagi, Kuki-shi, Saitama, Japan

Telephone: +81-480-52-1111

© 2013 SAKAI HEAVY INDUSTRIES, LTD. All Rights Reserved.

Printed in Japan 2013.11. 00 © C.D
0563-99007-0-30457-0

Printed in Japan 2017.08. 00 ① K.P
0563-99007-0-30457-C