

MODEL
SV544
SERIES

⚠ Read this handbook thoroughly and understand the whole information contained before trying to operate, inspect and service your machine!

**OPERATING &
MAINTENANCE
INSTRUCTIONS**

SAKAI HEAVY INDUSTRIES, LTD.

VIBRATING
ROLLER

MODEL

SV544 Series

**SV544D SV544DF
SV544T SV544TF
SV544TB SV544FB**

From	SV544D	→	3SV56	-	10489
	SV544T	→	3SV56	-	10489
	SV544DF	→	3SV56	-	10489
	SV544TF	→	3SV56	-	10489
	SV544TB	→	3SV56	-	10489
	SV544FB	→	3SV56	-	10489

SAKAI®

PREFACE

This operator's manual serves as a guide for the use of your SAKAI SV544 Series Vibrating Roller for those who are new to the machine, and also for the people who have experience in using the machine and want to refresh their knowledge for the machine.

Read this manual thoroughly and try to fully understand the information before operating your machine. Keep this handbook at hand whenever you do your work.

When an instruction manual is lost or is damaged and is not legible, replace it immediately.

The main subjects of this manual are:

(1) Basic precautions for safety, (2) Operation, (3) Daily maintenance and (4) Specifications. For operation and maintenance of the engine, refer to the Engine Instruction Manual furnished separately. Descriptions in this manual can differ from the machine instructions of your machine due to the results of the investigation and improvement in its design. If you have any inquiry regarding your Machine or this manual, contact our distributors.

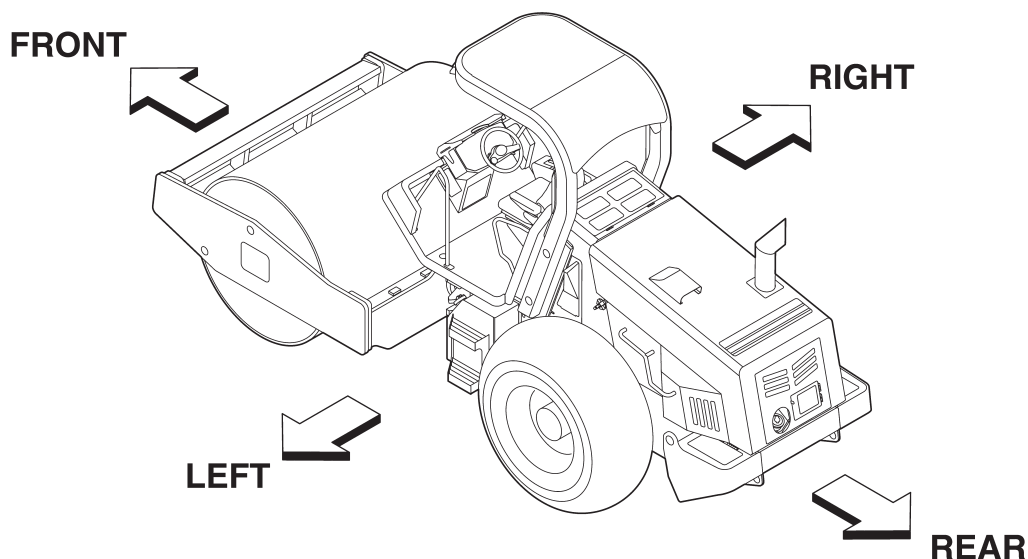

CALIFORNIA

Proposition 65 Warning

Diesel engine exhaust and some of its constituents are known to the State of California to cause cancer, birth defects, and other reproductive harm.

CONTENTS

PREFACE

MACHINE AND ENGINE IDENTIFICATION NUMBERS 1

SAFETY NOTICES 2

1 BASIC SAFETY PRECAUTIONS 4

1.1 General Precautions..... 4

1.2 Preparation for Safe Operation 8

1.3 Before Starting the Engine 9

1.4 After Starting the Engine 10

1.5 During Operation 11

1.6 Loading and Unloading 14

1.7 Transportation 15

1.8 Handling the Battery 15

1.9 Towing..... 16

1.10 Before Servicing 17

1.11 During Servicing 19

1.12 Safety Decals 22

2 OPERATION..... 25

2.1 Instruments and Controls 25

2.1.1 Operator's station 25

2.1.2 Gauges, indicator lamps and warning lamps..... 26

2.1.3 Switches 32

2.1.4 Operating levers / pedals..... 37

2.1.5 Unloader valve..... 38

2.1.6 Fuse box and line fuse..... 39

2.2 Handling and Adjustments 40

2.2.1 Seat adjustment..... 40

2.2.2 Scraper replacement and adjustment..... 41

2.2.3 How to replace the shells..... 44

2.2.4 Disengaging the brake when towing..... 53

2.2.5 Engine troubleshooting 54

2.3 Operation..... 55

2.3.1 Before-starting inspection 55

2.3.2 Starting the engine..... 56

2.3.3 After starting the engine..... 57

2.3.4 Traveling 58

2.3.5 Stopping / Parking 60

2.3.6 Stopping the engine..... 61

2.3.7 Check after stopping the engine 61

2.4 Vibratory Operation 62

2.5 Operating the DEF SCR System..... 64

2.6	Precautions for Work.....	69
2.6.1	Compaction operation.....	69
2.6.2	When going downhill.....	69
2.5.3	On a slope	69
2.7	Applicable Jobs	70
2.8	After Operation	71
2.9	Loading and Unloading	71
2.9.1	Use of a truck or trailer equipped with a winch	72
2.9.2	Self-propelling.....	72
2.10	After Loading the Machine	73
2.11	Transportation	73
2.12	Operation in Cold Weather.....	73
2.12.1	Fuel oil and grease	73
2.12.2	Coolant	74
2.12.3	DEF.....	75
2.12.4	Battery	75
2.13	When the Cold Season is Over	76
2.14	For a Long Storage Period	77
2.15	During the Storage Period.....	77
2.16	When the Battery has Discharged.....	78
2.16.1	Connection and disconnection of booster cables	78
3	PERIODIC MAINTENANCE	80
3.1	Precautions	80
3.1.1	Lifting the machine by hoist	83
3.2	Walk-around Checking.....	84
3.2.1	Tire inflation pressure check.....	85
3.2.2	Checking for external injury to a tire	85
3.3	Periodic Maintenance Points.....	86
3.4	Maintenance Procedure	88
(1)	Every 10 hours or daily.....	88
(2)	Every 50 hours	90
(3)	Every 250 hours	93
(4)	Every 500 hours	95
(5)	Every 500 hours or 3 months, or each time after brake pedal is used ..	99
(6)	Every 1000 hours	100
(7)	Every 4000 hours	102
(8)	As required	103
3.5	Consumable Parts.....	108
3.5.1	Changing the DEF pump filter	110
3.6	Fluid and Lubricant Capacities	112
3.7	Electric Wiring Diagram.....	115

1 BASIC PRECAUTIONS FOR SAFETY

4 SPECIFICATIONS.....	118
(1) SV544D	118
(2) SV544DF	119
(3) SV544T	120
(4) SV544TF	121
(5) SV544TB	122
(6) SV544FB	123

MACHINE AND ENGINE IDENTIFICATION NUMBERS

When ordering parts or making inquiries about your machine, the following information is requested.

(1) Machine model

Indicated on the nameplate of the left side of the operator's seat.

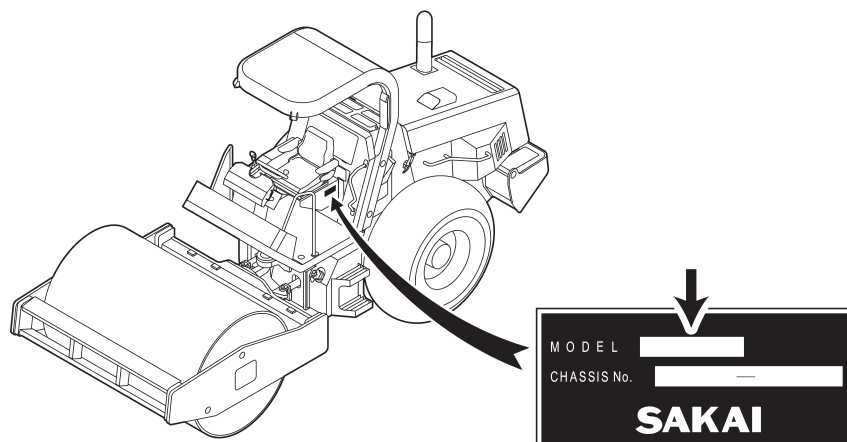

(2) Machine serial number

SV544D ⇨ 3SV56 - ○○○○○○
 SV544T ⇨ 3SV56 - ○○○○○○
 SV544DF ⇨ 3SV56 - ○○○○○○
 SV544TF ⇨ 3SV56 - ○○○○○○
 SV544TB ⇨ 3SV56 - ○○○○○○
 SV544FB ⇨ 3SV56 - ○○○○○○

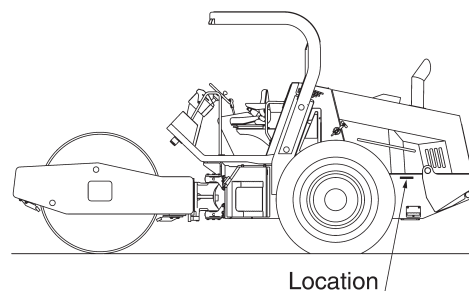

(3) Engine serial number

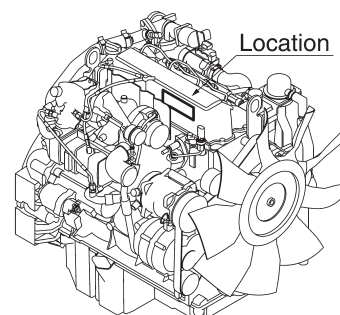







SAFETY NOTICES

For the safe use of your machine, correct handling and periodical maintenance are of utmost importance. Thoroughly read the safety precautions described in this manual. Do not attempt to operate and maintain your machine until you gain a full understanding of these safety statements.

This manual covers the proper and safe method of driving and handling of this machine for its intended use. When this machine is used in a manner other than those covered in this manual, you must assume responsibility for your own personal safety.

In this manual and on the machine, you will find safety notices. Each safety notice starts with a signal word as shown below:

- | | |
|--|---|
|  DANGER | Denotes that there is an extreme hazard. If you fail to take proper precautions, it is highly likely that you could be killed or seriously injured (The color of the symbol  is red). |
|  WARNING | Denotes that there is a hazard. If you fail to take proper precautions, you could be killed or seriously injured (Symbol  is orange). |
|  CAUTION | Calls attention to safety practices. If you fail to take proper precautions, you could be injured or cause damage to the machine (Symbol  is yellow). |

It is almost impossible for the safety notices in this manual and on the machine to cover all the potential dangers. Keep alert to possible dangers not mentioned in this manual and on the decals.

 **WARNING**

**Do not operate your machine before you read its operator's manual thoroughly.
Incorrect operation can kill or cause injury.
It is your responsibility to operate the machine safely.**

- ☆ Making alterations to the machine.
Please do not make alterations to the machine without permission for safety reasons.
We shall not be held responsible for injuries, death or breakdowns caused by alterations.
- ☆ Basic precautions for safe operation of your machine are described beginning on page 4.
- ☆ To operate and work with your machine, you must be qualified.



⚠ WARNING: Negligence of these instructions can lead to accidents.

1 BASIC PRECAUTIONS FOR SAFETY

1 BASIC PRECAUTIONS FOR SAFETY

1.1 General Precautions

■ Ensure proper management of health

- People under the influence of alcohol, drugs, lack of sleep or health problems must avoid driving or repairing the machine at all times, as it may lead to serious accidents.

■ Turn off cell phones

- Turn off cell phones while driving or repairing the machine. Never drive while talking on a cell phone, as it may lead to serious accidents.

■ Read the operator's manual thoroughly

- Understand the functions of the controls and gauges. Familiarize yourself with their location and how to operate them. Understand the meaning of all the symbols.



■ When an instruction manual is lost or is damaged and is not legible, replace it immediately

■ Understanding the uses for the machine

- This machine was developed and manufactured mainly for the purpose of rolling compaction in engineering works. Do not use it for any other purpose. Vibration rolling compaction under conditions of excessive compaction, or using it to crush rocks can damage the machine.

■ Obey the worksite rules

- Follow noise standards and worksite rules such as matters forbidden or to be attended to, and working procedures.





⚠ WARNING: Negligence of these instructions can lead to accidents.

1 BASIC PRECAUTIONS FOR SAFETY

■ Wear protective clothing appropriate to work

- Wear clothing, safety shoes and hard hat to suit your work.
- Do not wear clothing and accessories that tend to get caught in the controls or protruded portions of the machine. Do not wear oily clothing.
- Depending on the type of job, wear gloves, earplugs safety goggles or a mask.



■ Know the work area in advance

- Know the terrain, geology and conditions of the road surface at the worksite. Start working after securing safety such as stationing a guardsman or putting up barriers where there is a risk of falling of the machine or collapse of shoulder.

■ The operator must make prior checks when moving the machine to a hazardous area under unusual conditions

■ Provide against an accident

- Decide in advance the means of communication in an emergency. Know the location and use of an extinguisher and first-aid kit.

■ Realize the capability of the machine

- Thoroughly understand the performance of your machine and correctly operate the machine to meet the requirements of the job site. Operating the machine beyond its capabilities may lead to an accident. Use your machine within its capability.

■ The machines not equipped with ROPS must not be operated on the slope or unsafe ground

■ The machines not equipped with CABIN must not be operated in the bad weather or a harmful contaminated zone





⚠ WARNING: Negligence of these instructions can lead to accidents.

1 BASIC PRECAUTIONS FOR SAFETY

■ Do not use a machine which has not been serviced correctly at regular intervals

- Before working, perform necessary inspections. Start operation only after making certain the machine is in good operating condition. If found to be abnormal, report to the responsible person and have the fault corrected. Operate the machine after making sure that it is safe to operate.

■ Do not allow anyone to enter the work area except for authorized personnel

- Always conduct the work paying attention to the workers around the machine.



■ Beware when operating moving parts

- When operating moving parts such as covers, be sure to understand the way they move and take care not to get the hands and feet caught.

■ Operator must sit in the seat when operating the machine

■ Be careful of hot parts

- After your machine has operated for some time, the coolant, engine oil and hydraulic fluid will become hot and the pressure will build up. If, in this state, you try to remove the filler caps, drain the oil or replace the filters, you can get burned. Perform this work in accordance with the correct procedures with the machine cooled down.
- To remove the radiator cap, slowly loosen the cap to relieve the pressure with the engine stopped and the coolant cooled down (For the radiator cap with a lever, lift the lever to release the trapped pressure).
- When removing the filler cap on the hydraulic tank, release the trapped pressure by turning it out slowly to prevent the oil from gushing out (For the cap with a lever, lift the lever to release the trapped pressure).
- While the engine is running or immediately after it has been stopped, do not touch the engine, muffler, exhaust pipes, oil hydraulic pumps, oil hydraulic motors, lights, etc., as they will be hot.
- Resin and metallic parts may become hot under direct sunlight on a hot day. Direct contact with such parts may cause burns, so be sure to wear clothing and protective equipment appropriate for the job.





⚠ WARNING: Negligence of these instructions can lead to accidents.

1 BASIC PRECAUTIONS FOR SAFETY

■ Be careful with fire

- The fuel, oil, and antifreeze will catch fire if open flames or ignition sources are used close to them. Particularly, the fuel is highly flammable.
- Do not smoke or use a match or cigarette lighter close to inflammables (combustibles).
- When refueling, stop the engine and do not smoke.
- The filler caps of the fuel and oil tanks must be kept tight.



■ Ensuring safety in a fire

- Machine fires may cause serious injuries or death, so stop the engine by turning the starter switch to the OFF position, then move away from the machine as quickly as possible.

■ While the engine is running or immediately after it has been turned off, do not touch the muffler, exhaust pipe or DPF

- While the engine is running or immediately after it has been turned off, do not touch the muffler, exhaust pipe or DPF, as they will be hot.

■ Mount on or dismount from your machine after it has come to a complete stop

- For getting on and off, face the machine and use the handrail and step.
- Watch your step when getting on or off the machine.
- Do not jump on or off a machine, particularly when it is moving.
- When getting on and off an articulated machine, straighten it out before stopping the machine. In the turned state, there is danger that personnel gets caught because the getting on and off space narrows.

■ Be careful not to fall

- Falling off the machine may cause serious injuries or death, so do not place your feet anywhere other than on the steps, and in the driver's seat.

■ Do not lock out yourself when leaving the machines

- Always bring the key with you by pulling it out from the starting switch when leaving the machine.





⚠ WARNING: Negligence of these instructions can lead to accidents.

1 BASIC PRECAUTIONS FOR SAFETY

■ To handle the hydraulic fluid

- Wear safety goggles to protect your eyes from contact with hydraulic fluid. It can irritate your eyes.
If the fluid contacts your eyes, flush with clean water for 15 minutes and get medical aid.
- The fluid can also irritate your skin. When handling it, wear rubber gloves to avoid contact with it. In case of skin contact, wash with soap and water.
- Be careful not to swallow the fluid. It can cause diarrhea and emesis.
If swallowed, do not try to vomit. Get medical help immediately.



■ Do not use worn tires (Tire installed)

- Tires may be damaged when they are scratched on curb stones, when the machine runs over irregular surfaces of roads or projections on roads, and when the machine is operated suddenly.
- Continued use of damaged tires will cause them to blow out. Replace them with new ones.

1.2 Preparation for Safe Operation

■ Clean the step, operator's station and floor board and brake pedal

- Do not place parts, tools or unnecessary articles on the step, operator's station and floor board.
- Keep the step, floor board, brake pedal, controls and handholds free from muds, oil, ice or water, as they can cause slippage. Repair them if found to be damaged. Tighten loose bolts.
- Keep your boot soles free of oil or muds. They can slip, leading to an accident.

■ Inspect your machine before operation

- Check your machine for damage such as cracks and deformation. If found to be abnormal, operate the machine after taking a proper measure to secure safety.
- Check the level of fluids (fuel, engine oil, coolant, antifreeze and hydraulic oil). Add as necessary.
- Check the area where the machine has parked for signs of leakage of oil, fuel and water. If any leakage is noticeable, determine the cause and make corrections immediately.





⚠ WARNING: Negligence of these instructions can lead to accidents.

1 BASIC PRECAUTIONS FOR SAFETY

■ Watch your distance

- When traveling on a road, bear in mind the stopping distance. Avoid excessive speed, and abrupt starting and stopping, and moving in a zigzag direction.

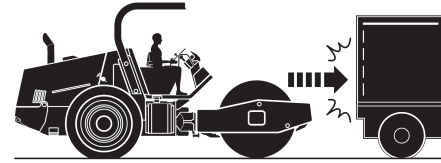

■ Understand ROPS functions (with ROPS)

- Ensure that there is no loose bolt, crack nor rust on the bodies and the attaching portions, of ROPS.
- Tighten bolts with the specified torques after ROPS are removed.
Tightening torque : **883 N·m**
- Do not weld nor drill holes to the ROPS parts without the permissions from SAKAI, because it may decrease strengths of the ROPS.
- Be sure to wear the seatbelt during operation.

1.3 Before Starting the Engine

■ It is confirmed that hood and door is closed

- Please confirm hood and door has put it away in the confirmation before it gets on.

■ Adjust the operator's seat to your most effective operating position

- Sit on the operator's seat. Adjust the seat so that your back will make contact with the seat back when the brake pedal is pressed down to the full extent. Check to be sure that the brake pedal can be fully pressed down without difficulty when you twist your body for reverse run.
- Adjust the seat to allow proper operation of the steering wheel, levers, switches, etc.

■ Secure good visibility (with CABIN)

- Keep the windowpanel clean.
- Lock the windows and doors no matter whether they are open or closed.
- Do not leave the doors half-closed.

■ Secure forward and backward visibilities

- Adjust the rear view mirrors and under mirrors for good visibility. If dirty, clean them. If damaged, replace.





⚠ WARNING: Negligence of these instructions can lead to accidents.

1 BASIC PRECAUTIONS FOR SAFETY

■ Check that the horn, lamps and gauges work correctly

■ Before starting, make certain that each lever is in the neutral position and the parking brake is applied

■ When starting, sound the horn

- Before starting the engine. Make sure there is no one in the immediate vicinity and there are no obstructions around the machine.



■ Sit in the driver's seat and turn on the engine

- Do not start the engine anywhere other than from the driver's seat as there is the danger of operational mistakes.

■ Pay attention to ventilation

- Exhaust fumes are dangerous if breathed in. When starting the engine in an enclosed area, provide good ventilation with windows and doors opened.



■ Do not stand close to the exhaust gas pipe opening

- The exhaust gas from the engine is dangerous.
- Exhaust fumes are harmful if breathed in.

1.4 After Starting the Engine

■ Secure safety around the machine

- Ensure that the area around the machine is clear of personnel and obstructions. Moreover, honk the horn, indicate your intention to move, and wait a while before moving off.



■ Warm up the engine

- Do not put your machine into motion immediately after the engine has started, let it idle for several minutes until it is at operating temperature.
- Check the area where the machine has parked for signs of leakage or oil, fuel and water. If any leakage is noticeable, determine the cause and make corrections immediately.





⚠ WARNING: Negligence of these instructions can lead to accidents.

1 BASIC PRECAUTIONS FOR SAFETY

■ Have a trial run

- Make a test run in a safe place to check that there are no abnormal signs. If found to be abnormal, correct the fault before traveling again.
- Listen for unusual sounds, and check for abnormal temperature rise. If abnormal, park the machine in a safe place and find the source of trouble before operating.

1.5 During Operation

■ Strictly observe the traffic regulations

- Follow all the traffic regulations when driving on a public road.

■ Sit in the driver's seat before starting operation

- Sit in the driver's seat before starting operation. Be sure to wear the seat belt when provided.

■ Seat belt (with seat belt)

- Be sure to wear the seat belt during operation.

■ No other person but the operator

- This machine is a one-man roller. Do not allow anyone to get on. Only the operator is allowed on this machine while it is running or in operation.

■ Before mounting, be sure areas around the machine are safe

- Before getting on the machine, make certain that there are no obstacles around the machine and no workers under it. If some workers are present or close to the machine, tell them that the machine is about to move, warning them to stay away from it.

■ Do not try to get on or off a moving machine

- Get on or off the machine after making sure it has come to a complete stop and the parking brake is applied.

■ Do not let anyone enter the work area

- There is the danger of being run over causing serious injuries or death.
- If the driver does not have a clear field of vision, assign a conductor ensure peripheral safety.





⚠ WARNING: Negligence of these instructions can lead to accidents.

1 BASIC PRECAUTIONS FOR SAFETY

■ To go uphill or downhill, run at a low speed.

Do not attempt to shift speeds while traveling on a slope

- Shifting speeds on a slope can cause unexpected running down the slope.
- Going down hill at speeds other than low range can cause the machine to run down violently.



■ Refrain from inattentive driving

- Inattentive driving or driving relying on guess work can cause an accident. Use extreme care for workers present in the path of machine or around it. In case of danger, stop and sound the horn, and proceed when the area is clear of personnel or obstructions.

■ When changing the direction of travel, secure the safety on the path in the travel direction

■ Keep everyone away from the pinch points

- When making turns, do not allow anyone to come close to the pinch point.

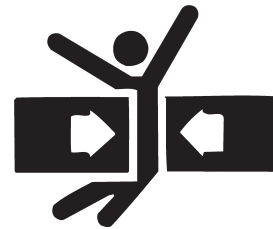

■ At night, carefully drive the machine

- Nighttime driving tends to frustrate the sense of distance. Carefully drive the machine at a speed suited to illumination. Keep the headlamps and flood lamps lighted. If necessary, provide extra lighting in the work area.

■ Avoid long hours of continual operation

- Avoid long hours of continual operation as it may lead to loss of health.

■ Repair as soon as possible if found to be defective

- If the machine is found to be faulty, stop the machine and repair. Do not operate the machine until the problem is corrected. When any warning lamp indicates faulty operation, inspect the machine after moving it to the nearest safe location.





⚠ WARNING: Negligence of these instructions can lead to accidents.

1 BASIC PRECAUTIONS FOR SAFETY

- **The machines not equipped with ROPS must not be operated on the slopes or unsafe ground**

- **The machines not equipped with CABIN must not be operated in the bad weather or a harmful contaminated zone**

- **Do not operate the machine except from the operator's seat. Do not drive in a standing posture**
 - Do not throw your legs out or lean forward. Be sure to sit in the proper position while driving the machine.

- **While making turns, do not run at abnormally high speed and do not turn the steering wheel abruptly and sharply. High speed turns, especially on soft or uneven ground, could result in a rollover**

- **For the traveling on structures such as a bridge, make certain that they can support your machine. Before traveling on the structure, you must know the load capacity of the structure and the load weight of the machine you are operating to insure safe travel across the structure**

- **Do not make turns on a slope and do not travel across sidehill. If necessary to do so, go down straight along the slope to the flat ground, move sideways and go up straight to the destination**

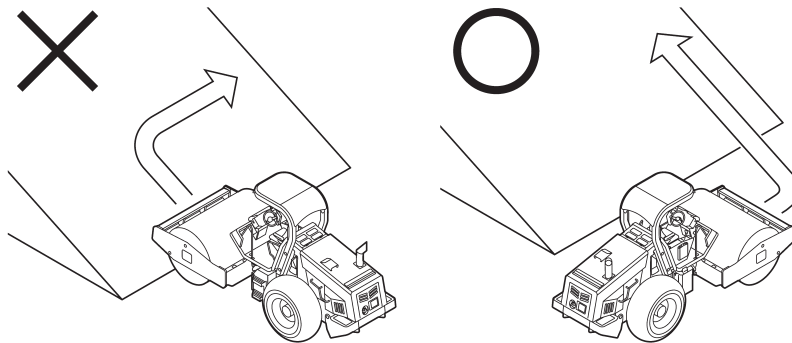

- **On a steep slope, run the machine at low speed**





⚠ WARNING: Negligence of these instructions can lead to accidents.

1 BASIC PRECAUTIONS FOR SAFETY

■ When parking

- Select level and hard ground. If necessary to park on a slope, chock the front of the drum and tire on the downside of the slope.
- When required to park on the public road, provide necessary markings such as flag, barriers and illumination. However, be sure they do not obstruct traffic.
- Stop the engine when getting off the machine. Remove the key from the starter switch, and make sure it is stored appropriately.
- Be sure not to get your hands caught in the chocks when handling them.

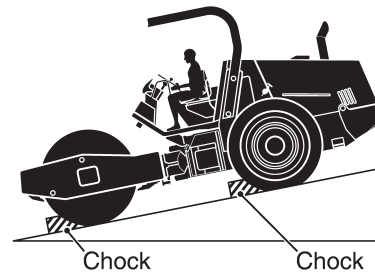

■ Beware of deformation in tires during long-term parking (if tires installed)

- The surfaces of tires in contact with the ground may become flattened, leading to their deformation (forming of flat spots) during long-term parking.
- The forming of flat spots may cause bounding or shaking during operation of the machine.
- After the forming of flat spots, driving the machine will restore the tires and remedy the situation.
- To prevent the forming of flat spots during long-term parking, inflate the tires to a higher pressure within the allowable range and drain the water from the sprinkler tank before parking. Furthermore, move the machine regularly.

1.6 Loading and Unloading

- Loading and unloading can accompany any danger. Use extreme care.
- Select level and hard ground leaving a sufficient distance from the shoulder of a road or bank.
- Use sturdy ramps with proper width, length and thickness which allow safe loading and unloading. If they deflect considerably under load, apply wooden blocks to reinforce the ramps.
- To prevent your machine from crosswise slippage, keep the ramps free from oil, mud, debris, etc. The drum must also be free from extraneous matter that can cause slippage.
- Do not steer your machine on the ramps. If the machine is facing in the wrong direction, go back off the ramp, correct the direction and try again.
- Do not use kinked, twisted or damaged wireropes for crane or winch operation. Use ones with ample strength.
- When loading is complete, fix the machine with wooden blocks placed under the drums and chains fastened to the machine.

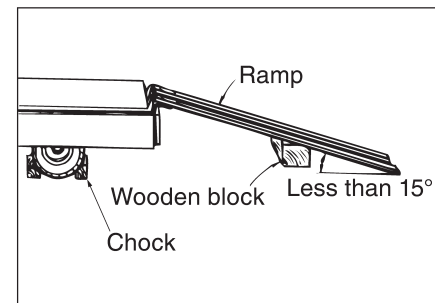



⚠ WARNING: Negligence of these instructions can lead to accidents.

1 BASIC PRECAUTIONS FOR SAFETY

1.7 Transportation

- Follow required regulations.
- Select a transporting route according to the overall width, overall height and gross weight of the trailer with the machine loaded.
- Know the maximum height clearance of the machine loaded on the transport trailer before hauling under bridges and other structures.

1.8 Handling the Battery

■ When handling the battery

- Battery electrolyte contains sulphuric acid. It will destroy clothing and skin. If it touches your clothing or skin, flush with large quantities of water.
- In case of eye contact, flush with clean water and get medical help.
- If swallowed, drink large amount of water, milk, beaten egg or vegetable oil, and get medical help.
- Wear safety goggles when handling the battery. Wear safety goggles, full face shield, rubber gloves and rubber apron when adding fluids to the battery.
- Keep cigarettes and flames away, and avoid recharging the battery in poorly ventilated places when there is a danger or generating sparks.



⚠ WARNING

Battery posts, terminals, and related accessories contain lead and lead compounds, chemicals known to the State of California to cause cancer and reproductive harm. Wash hand after handling.

- Inspect or handle the battery with the engine stopped and the starter switch in the OFF position.
- Turn the starter switch to the OFF position, then wait at least 30 seconds before removing the battery. An abnormality may arise in the ECM (engine control module).

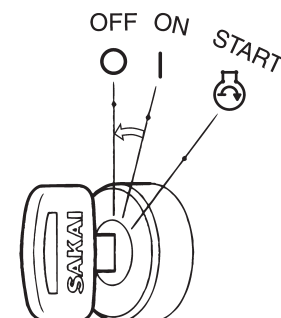



⚠ WARNING: Negligence of these instructions can lead to accidents.

1 BASIC PRECAUTIONS FOR SAFETY

- Keep metallic items such as tools away from the battery terminals.
- Tangled terminals may generate sparks due to improper connections, resulting in the danger of explosions. Make sure terminals are connected firmly.
- The battery is for starting the engine and operating electrical equipment on the machine. Do not use it for any other purpose.
- Do not charge battery when the top surfaces of the liquids are at the LOWER level (the minimum liquid level) or below. Not only the internal parts of the battery are degraded and the battery lifetime are shortened but also it can cause explosions if you continue on using the battery when the top surfaces of the liquids are at the LOWER level or below. Immediately supply water until the water level is between the UPPER and LOWER levels.

■ Jump-starting the engine

- Wear safety goggles when jump-starting the machine.
- When starting from another machine, do not allow the two machines to make contact with each other.
- When connecting the battery cables, start with the positive terminal. For disconnection, start with the negative one.
- Do not allow a tool to bridge between the positive terminal and machine body. This can generate dangerous sparks.
- Do not connect the booster cable to wrong the terminal. Never connect the positive terminal to the negative terminal or the body of the machine.
- Final connection to the engine block of the disabled machine can cause sparks. The connecting point should be as far as possible from the battery.

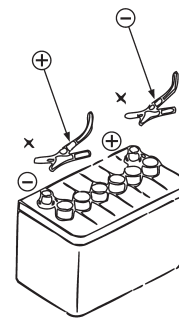

1.9 Towing

- Towing should only be carried out in emergencies and over short distances. A trailer should be used for long distance transport.
- The machine should not be operated while being towed.
- Follow the instructions in this manual to enable towing.
- Do not tow if the braking system has broken down, as it is dangerous.
- To tow the machine, use cables with ample strength.
- Do not perform towing on a slope.
- Be sure to attach a wire rope firmly to the towing hook.
- Do not use twisted, kinked or damaged cables when towing.
- Do not step over the wire rope.
- Keep everyone away from the space between the machine and the towing machine when connecting the two.
- Align the connection points of the disabled machine and the towing machine in a straight line when connecting the machines.





⚠ WARNING: Negligence of these instructions can lead to accidents.

1 BASIC PRECAUTIONS FOR SAFETY

1.10 Before Servicing

■ Attach warning tags when servicing the machine

- Serious accidents can occur if the machine is unexpectedly started or controls carelessly touched by an unauthorized person.
- Attach a warning tag at a clearly visible location in the operator's station and insure the key has been removed from the starter switch.



■ Setting the chocks

- Set chocks in front of and behind the roller drum (wheels) to prevent the machine from moving before beginning inspections or maintenance work.

■ Use proper tools

- It is very dangerous to use damaged or deteriorated tools or to use tools for other purposes than intended. Use correct tools for their intended use only.



■ Change safety-related parts at regular intervals

- Change any seatbelt found to be abnormal even if it is within its recommended service interval.
 - Change any ROPS found to be abnormal even if it is within its recommended service interval.
 - Replace fuel hose, high pressure hydraulic hoses and liquid hoses regularly to prevent fire. Replace high pressure hoses of the power steering system every two years.
- ☆ Change these parts at regular intervals even if found to be normal. They will deteriorate as time goes on.
- ☆ Change any hose found to be abnormal even if it is within its recommended service interval.





⚠ WARNING: Negligence of these instructions can lead to accidents.

1 BASIC PRECAUTIONS FOR SAFETY

■ Inspect or service your machine with the engine stopped

- If required to keep the engine running in such a case as radiator interior cleaning, perform the work with two persons. One of them should sit on the operator's seat getting ready for shutting down the engine. He must take care not to touch any of controls carelessly. Maintenance personnel must exercise extreme caution not to make contact with moving parts.

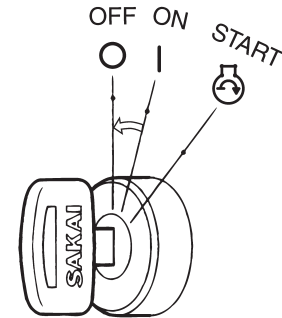

■ Supplying fuel, oils and grease

- Do not cover the filler port when refueling. Feeding fuel in an airtight tank might damage the fuel tank.
- Spilled fuel or oil will be slippery. Wipe up immediately. Keep the filler caps tight. Do not use fuel for flushing oil. Handle fuel and oil in a well ventilated area.

■ Check the coolant level in the radiator

- To check the coolant level, stop the engine and allow the engine and radiator to cool down before removing the radiator cap. Remove the cap by covering it with a rag before removing to prevent any fluid that could spray under pressure from causing a burn.

■ Illumination

- For inspecting the level of the fuel, oil, coolant and battery electrolyte, use explosion-proof illuminations. Failure to use this type of illumination can result in an explosion.



■ Make sure the gas dampers are properly maintained

- Before inspecting the engine room, make sure the gas dampers holding up the hood are firmly engaged. Furthermore, in machines with stays to prevent the hood from closing, make sure they are firmly in place.

■ Points to beware of when filling the sprinkler tank with water (on machines equipped with a sprinkler tank)

- Do not fill the tank with the water inlet blocked. It may damage the sprinkler tank.





⚠ WARNING: Negligence of these instructions can lead to accidents.

1 BASIC PRECAUTIONS FOR SAFETY

1.11 During Servicing

■ Keep unauthorized persons away

- During service, do not allow persons not concerned to enter the work area, particularly when grinding or welding operation is performed or heavy hammers are being used.



■ Assume an appropriate posture while working

- An unnatural posture during maintenance work may cause injuries. Assume a posture that is appropriate for the work being carried out.

■ Keep your machine clean

- Spilled oil, grease or scattered debris are dangerous. Always keep your machine clean. Moisture that penetrates into the electrical system can cause malfunctions. Do not use water to clean sensors, connectors and the operator's station.

■ Take care not to get caught or crushed

- Be sure to fix the hood and other covers after opening them to prevent closing and avoid getting caught in them.
- If there is a need to crawl under the machine after it has been lifted, be sure to support it from underneath with a solid prop or block.

■ When repairing the electrical system

- Read the warnings in this manual regarding the handling of batteries, and make sure to have a thorough understanding in order to handle them appropriately and safely.
- When repairing the electrical system or welding, disconnect the negative cable from the battery to shut off the electricity. Carrying out work while the cables are connected to the negative terminal may cause electrocution or explosions.



■ Carefully handle high pressure hoses

- Do not try to bend or hit hoses against a hard object. Do not use hoses or pipes that are bent or damaged. They will burst.
- Replace damaged fuel hose, hydraulic hoses and liquid hoses. An oil, hydraulic and liquid fluid spill can cause a fire.





⚠ WARNING: Negligence of these instructions can lead to accidents.

1 BASIC PRECAUTIONS FOR SAFETY

■ Be careful of high pressure hydraulic fluid

- Bear in mind that the working equipment hydraulic systems are under internal pressure. Do not perform adding, draining, inspection or servicing of the hydraulic systems until the internal pressure has been relieved. Hydraulic fluid leaking through a fine hole at high pressure can penetrate your skin and eyes. Inspect leakage by holding a hard board close to suspected leaks wearing goggles. If affected by high pressure oil, get medical help immediately.



■ Be careful of hot parts

- After the machine has been operated for some time, the coolant, engine oil and hydraulic fluid will become hot.
- Removing the radiator cap or draining the coolant or oil can burn you. Perform this work in accordance with correct procedures after the systems have cooled down.



■ Use care when inspecting or servicing fan or belts in motion

- Do not wear clothing and accessories that tend to get caught in moving parts.
- Do not let your body or tools make contact with the fan blades or belts. They can be cut seriously.



■ Used oil disposal

- Do not throw used oil into a drain or waterway. Drain the oil from the machine into a proper container. Do not drain directly on the ground.
- Obey all local, state and federal environment regulations for the proper disposal of oil, fuel, coolant, battery electrolyte or any other fluids.

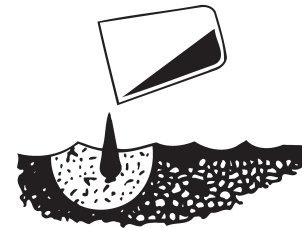



⚠ WARNING: Negligence of these instructions can lead to accidents.

1 BASIC PRECAUTIONS FOR SAFETY

■ Take care in handling the gas damper

- Never dismantle it.
- Do not throw it into a fire.
- Do not damage the rod.
- Do not bend the tube or rod, or use it as a handle.
- When disposing of it, be sure to fix the gas damper, and drill a hole around 2 to 3 mm in diameter, about 20 to 30 mm from the edge on the tube bracket side. Dispose of it after releasing the gas pressure. When doing this, be sure to wear protective goggles because of the danger of oil inside or swarfs getting sprayed everywhere by the compressed gas inside.

■ Exercise extreme care when replacing and repairing tires (Tire installed)

- Disassembly, repair and reassembly of tires require special facility and knowledge. Have them repaired at work shop specialized in handling tires.
- An improperly fitted tire can separate from the rim when inflating.
- When dismounting a tire, chock other tires for safety.
- When welding job is carried out near the tires, use extreme care, as this can cause an explosion of the tires.





⚠ WARNING: Negligence of these instructions can lead to accidents.

1 BASIC PRECAUTIONS FOR SAFETY

1.12 Safety Decals

Keep all decals clean. If lost, replace with new one. There are decals other than those shown below: Treat them in the same manner as the one shown here.

① 3998-16500-0

⚠ WARNING

- Avoid inhalation of exhaust gas.
- Avoid contact with exhaust pipe while engine is running and after it has been stopped. Contact with hot exhaust pipe will cause burns.

3998-16500-0

④ 3998-16510-0

⚠ CAUTION

Refill the specified quantity of oil in the vibrator case when changing oil.

3998-16510-0

⑧ 3998-16559-0

DANGER EXPLOSIVE GASES
Cigarettes, flames or sparks could cause battery to explode. Always shield eyes and face from battery. Do not charge or use booster cables or adjust post connections without proper instruction and training.

KEEP VENT CAPS TIGHT AND LEVEL

POISON CAUSES SEVERE BURNS
Contains sulfuric acid. Avoid contact with skin, eyes or clothing. In event of accident flush with water and call a physician immediately.

KEEP OUT OF REACH OF CHILDREN

3998-16559-0

② 3998-16499-0 (2 locations)

⚠ WARNING

- Do not open the hood with the engine running.
- Contact with hot parts will cause burns.
- Contact with rotating parts will cause severe injury.

3998-16499-0

⑤ 3998-16468-1

⚠ CAUTION

PREVENT THE LOCKING OF PARKING BRAKE
When the vehicle storage for the long term, release the parking brake and travel to vehicle for a little while, then put the parking brake on again. Do this operation once a month at least.

3998-16468-1

⑨ 1418-19108-0

⚠ WARNING

Brace hood with stay after opening the engine compartment.

1418-19108-0

⑥ 3998-16701-0 (3 locations)

3998-16701-0

⑩ 1418-19107-0

⚠ WARNING

Chock the machine before operating the unloader valve.

1418-19107-0

③ 3998-16504-0

⚠ WARNING

- When Handling the Machine:**
 - Operate only while seated.
 - Use the handrails and steps when boarding and getting off.
 - Never carry passengers.
 - Never attempt to board or get off the machine while it is moving.
- Preparation for Safe Operation**
 - Clean the steps, operator's station and floorboards.
 - Obey the worksite rules.
 - Sakai accepts no responsibility for any injury or damage to the machine caused by unapproved modification.
 - Do not use a machine which needs repair or maintenance.
 - Sound the horn immediately prior to starting the engine to warn people in the vicinity.
- Starting the Engine**
 - Check that all operating levers are in the neutral position.
 - Idle the engine for about 5 minutes to warm it up prior to commencing work.
- Parking Precautions**
 - When parking the machine, park it on level ground, set the parking switch and set the roller chocks.
 - Allow the engine to cool off by running it for about 5 minutes before stopping.
 - When getting off the machine, remove the key from the ignition switch.

3998-16504-0

⑦ 1418-19109-0

⚠ CAUTION

USE SPECIFIED DEF ONLY

- Use of nonconforming DEF may result in damage to the SCR system.
- Please refer to the manual for details.

1418-19109-0

⑪ 3998-19678-0 (2 locations)

3998-19678-0

⑫ 3998-16646-1

3998-16646-1



⚠ WARNING: Negligence of these instructions can lead to accidents.

1 BASIC PRECAUTIONS FOR SAFETY

⑬ 3998-16505-0

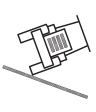
	⚠ DANGER
	<p>Roll Over Prevention</p> <ul style="list-style-type: none"> Do not work in the vicinity of overhanging banks, or on grades steep enough to cause the machine to slide or roll over. Reduce speed prior to making turns. Pay particular attention when operating on uneven surfaces, as the machine may become unstable. <p style="text-align: right;"><small>3998-16505-0</small></p>

⑱ 1418-19106-0

⚠ WARNING
<p>Turn the unloader valve clockwise before releasing the brake. Ensure the unloader valve is shut.</p> <p style="text-align: right;"><small>1418-19106-0</small></p>

⑳ 2998-96001-1

⚠ CAUTION
<p>USE SPECIFIED FUEL ONLY</p> <ul style="list-style-type: none"> Use of other than the specified fuel may result in damage to the engine. Please refer to the manual for details. <p style="text-align: right;"><small>2998-96001-1</small></p>



⑭ 1411-19036-2

	⚠ WARNING
	<ul style="list-style-type: none"> Travel downhill in Rabbit may cause engine damage. Use Turtle on slopes. RPM MAX: 2500 rpm Do not attempt to shift speeds during travelling. <p style="text-align: right;"><small>1411-19036-2</small></p>

⑲ 3998-06139-0



⑮ 3998-16696-0

⚠ DANGER
 <ul style="list-style-type: none"> Do not approach, or allow objects to touch the rotating parts. Body parts which make contact with rotating mechanism will be severed.
 <ul style="list-style-type: none"> Do not open the radiator cap and the auxiliary tank cap when fluid is hot. Radiator fluid is flammable. Avoid exposure to flame when the cap has been removed.
 <ul style="list-style-type: none"> Avoid contact with machine parts in the vicinity of the engine while engine is running and after it has been stopped. Contact with hot part will cause burns. <p style="text-align: right;"><small>3998-16696-0</small></p>

⑳ 3998-16724-0





<small>3998-16724-0</small>

⑯ 3998-16680-0

⚠ CAUTION
 <p>Reference service manual for special fill procedure. Failure to follow this procedure can result in severe engine damage.</p> <p style="text-align: right;"><small>3998-16680-0</small></p>

㉑ 3998-16501-0

⚠ DANGER
 
<p>Be Careful with Fire</p> <ul style="list-style-type: none"> When refueling, stop the engine and do not smoke. The filter cap of the fuel tank must be kept tight. <p style="text-align: right;"><small>3998-16501-0</small></p>

⑰ 1418-19105-0

⚠ CAUTION
<p>To prevent accidents, stop engine before fueling.</p> <p style="text-align: right;"><small>1418-19105-0</small></p>

⚠ WARNING: Negligence of these instructions can lead to accidents.

1 BASIC PRECAUTIONS FOR SAFETY

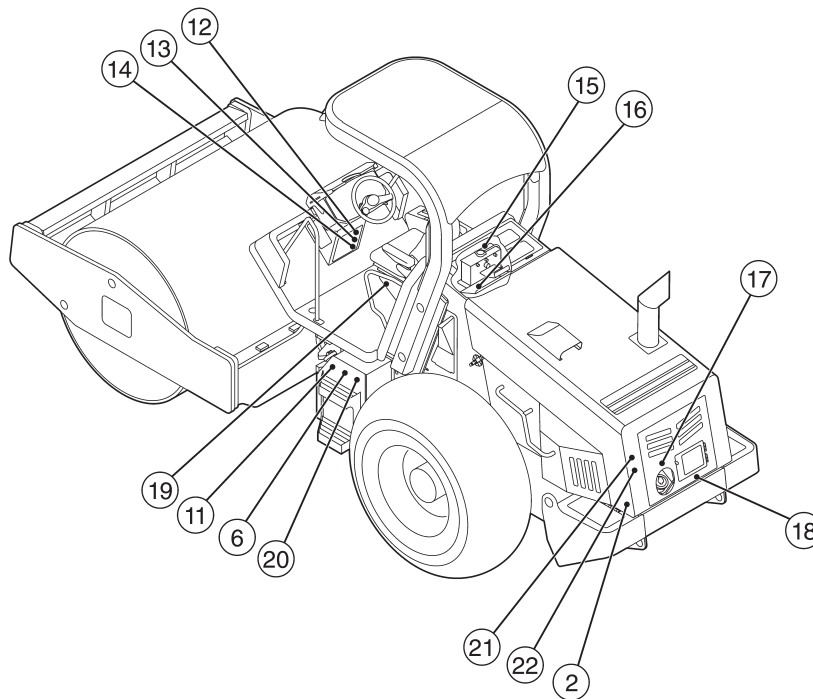
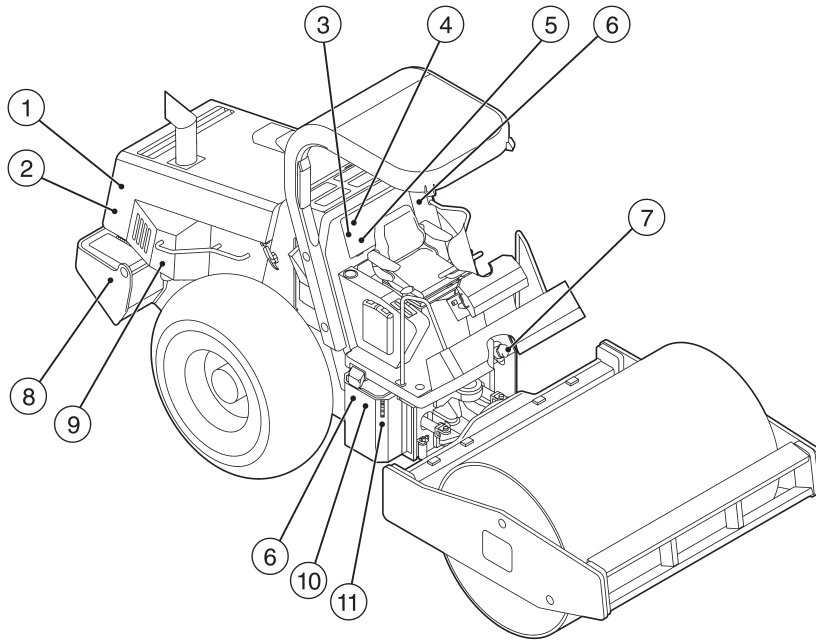

2 OPERATION

2.1 Instruments and Controls

2.1.1 Operator's station

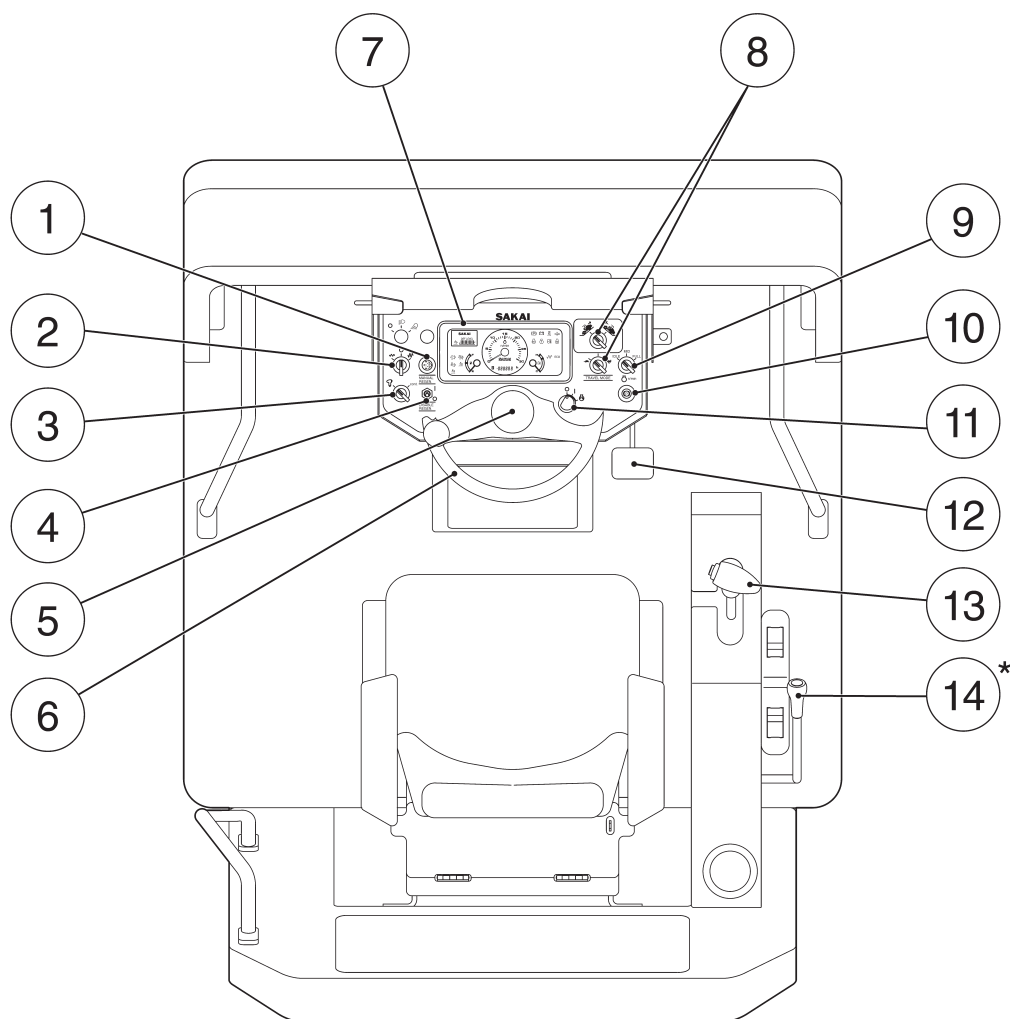

- | | |
|-------------------------------|--|
| ① Manual regeneration switch | ⑨ Engine speed select switch |
| ② Vibrator switch | ⑩ Parking brake switch |
| ③ Vibration selector switch | ⑪ Starter switch |
| ④ Disable regeneration switch | ⑫ Brake pedal |
| ⑤ Horn switch button | ⑬ Forward-Neutral-Reverse (F-N-R) lever
with vibration switch |
| ⑥ Steering wheel | ⑭ Leveling blade lift lever |
| ⑦ Combination meter | |
| ⑧ Travel mode switch | |



* For SV544TB, SV544FB only.

2 OPERATION

2.1.2 Gauges, indicator lamps and warning lamps

For safe execution of your job, fully understand the role and function of the systems involved.

Combination meter

Post-processing equipment display monitor( part) OK monitor display ( part)

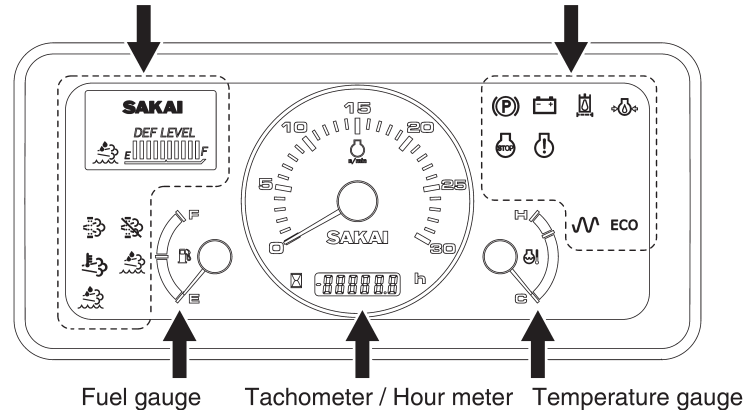

Tachometer / Hour meter

Indicates the engine RPM. The hour meter shows total operating hours. The service interval recommendation in this manual should be based upon the hour meter readings.

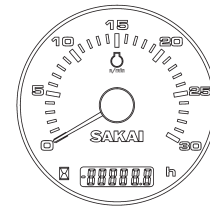

Tachometer / Hour meter

Temperature gauge

Indicates the coolant temperature. Zone close to symbol H indicates overheating. In case of overheating, run the engine at idling for about ten minutes before shutting it down. Then determine the cause.

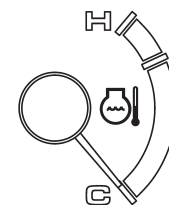

Temperature gauge

Fuel gauge

Indicates the fuel level in the tank.

E: The tank is empty.

F: The tank is full.

Replenish fuel appropriately before the fuel runs down.

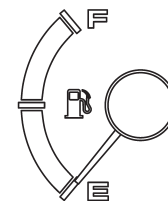

Fuel gauge

⚠ CAUTION

Be sure to use fuel recommended by SAKAI (refer to page 113).

OK monitor display

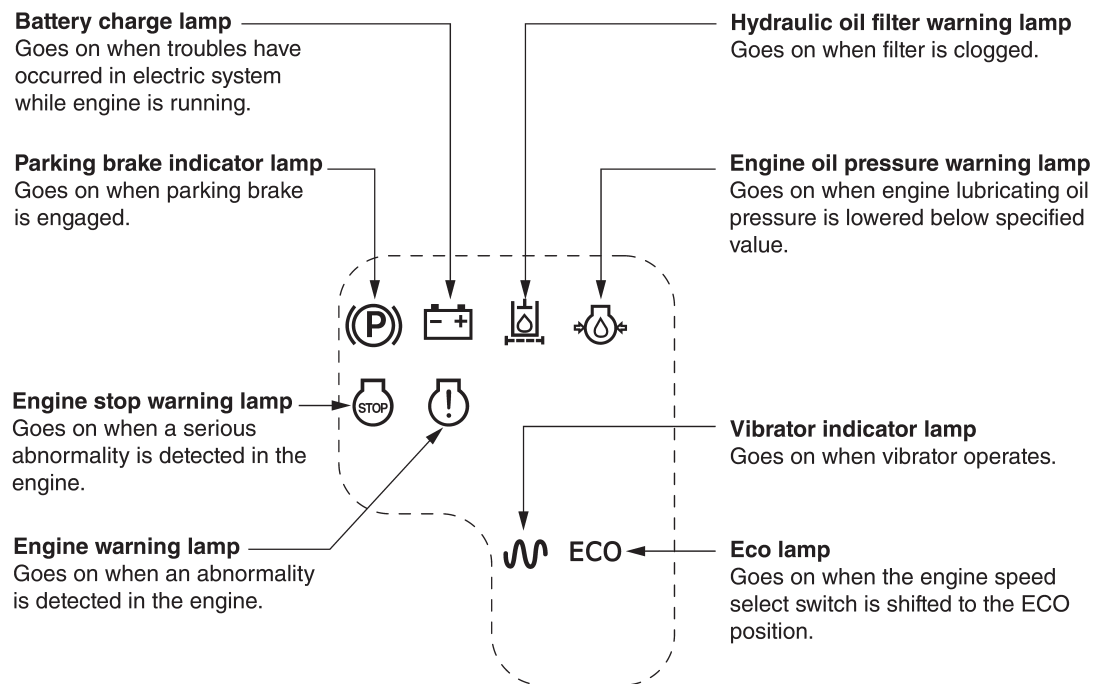

- ★ Indicator lamps [ECO]
Light up when corresponding systems have been operated.
- ★ Parking brake indicator lamp []
It will flash once when the starter switch is turned to the “I” position.
After that it will remain on while the parking brake is engaged, and turn off when it is released.
- ★ Hydraulic oil filter warning lamp []
It will flash once when the starter switch is turned to the “I” position.
After that it will turn on when the hydraulic oil filter becomes clogged. Stop the machine and carry out an inspection.
- ★ Engine oil pressure warning lamp []
It will turn on when the starter switch is turned to the “I” position, and turn off when the engine starts running.
It will turn on while the engine is running if the engine oil pressure drops below the specified value. Stop the machine and carry out an inspection.
- ★ Battery charge lamp []
It will turn on when the starter switch is turned to the “I” position, and turn off when the engine starts running.
It will turn on while the engine is running when a problem arises with the electric system. Stop the machine and carry out an inspection.

2 OPERATION

IMPORTANT

- **Hydraulic oil filter warning lamp**
Go on when the engine rpm is increased before the engine has been warmed up enough. Keep the engine idling until the lamp goes off, before starting your work. In that case, warm up the engine sufficiently, and operate the machine after the warning light has gone out. When the warning light will not go out, the filter may be clogging up. Check the filter.
- **Checking for warning lamp and parking brake indicator lamp**
They should turn on light when the starter switch in “I” position.
If not, there is some trouble.
Check and repair the combination meter or wirings harness.
- **The window of the combination meter**
The window of the combination meter may become invisible because of aged deterioration caused by fine sand or dust or ultraviolet. When any flaw or mist is found on the window, contact our branch offices or designated factory.

Engine check lamp

When the start switch is set to the “I” position, self-diagnosis of the engine will start.

When the result is normal, three lamps will go out.

If the lamp remains lit or it lights during operation, it means there is any trouble with the engine. Stop the machine to check the engine.

★ ENGINE STOP WARNING

When the engine stop lamp lights, it means a serious abnormality occurs with the engine. Stop the machine and the engine, and receive proper checking / maintenance or repairing.



ENGINE STOP WARNING

★ ENGINE WARNING

When the warning lamp lights, water may be accumulated in the fuel pre-filter.

Drain the fuel pre-filter (refer to page 89).

If the lamp lights just because the water is accumulated in the fuel pre-filter, it will go out after draining.

If the lamp does not go out, the engine may be abnormal. Receive proper checking / maintenance or repairing before a serious failure occurs.



ENGINE WARNING

IMPORTANT

For the details of the engine check lamp, see the instruction manual of the engine.

Eco lamp

ECO lamp is turned on if the Engine speed select switch is shifted to ECO position. It runs under the fuel-efficient mode when the ECO lamp is turned on.

Normal vibrator speed occurs in ECO mode.

ECO
Eco lamp

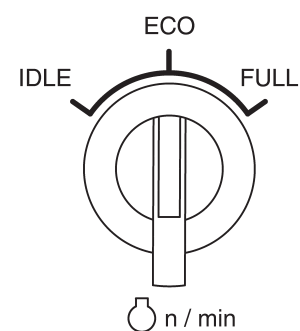

Engine speed select switch

2 OPERATION

Post-processing equipment display monitor

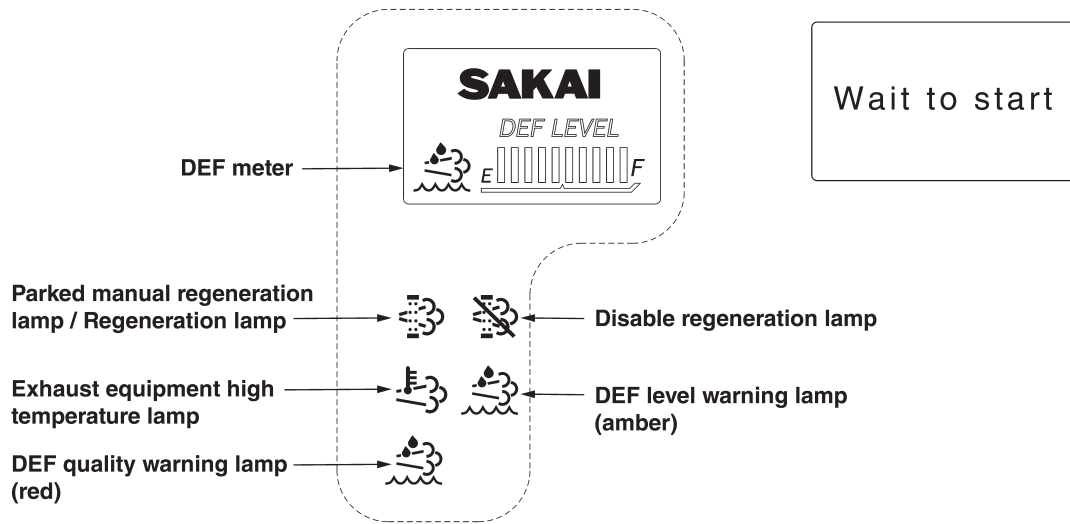

★ DEF meter

Indicates DEF level in DEF tank

E: Indicates there is no DEF left

F: Indicates tank is full

Do not use DEF until tank is empty, but fill it up regularly.

Refer to "Operating the DEF SCR System" for more details.



⚠ CAUTION

- Using the machine when the DEF level is low will the warning lamp will turn on or flash. A limit will also be placed on the engine output, not allowing the machine to perform to its full potential. Never use the machine in such a state.
- Use AUS32 for the DEF, or an ISO 22241-1 certified DEF.
Do not use anything else. If any kind of additive or water is mixed into the DEF, the machine will not be able to function properly, and it will not satisfy exhaust gas emissions standards. It will also damage the engine system.
If the tank is filled with any fluid other than DEF, contact one of our sales offices for advice.

- ★ Parked manual regeneration lamp / Regeneration lamp
Turns on and flashes during regeneration of the SCR or when parked manual regeneration is needed.



- ★ Disable regeneration lamp
Turns on while SCR automatic regeneration is disabled.



- ★ Exhaust equipment high temperature lamp
Turns on when exhaust equipment is hot during, e.g., SCR regeneration.



- ★ DEF level warning lamp (amber)
Turns on or flashes when the DEF level in the tank falls below the standard level.



- ★ DEF quality warning lamp (red)
Turns on or flashes when the DEF concentration is below the minimum required value, or something other than DEF is detected.
It may also turn on when the DEF concentration approaches the minimum required value.



Engine check lamp

When the WAIT TO START lamp is turned on, it means self-diagnosis of the engine, and the engine should not be started.

Must wait to start the engine. The most common reason for this is to wait for the intake air heaters to complete a pre-heat cycle during cold ambient conditions.

Wait to start

2 OPERATION

2.1.3 Switches

Starter switch

Starts and stops the engine.

- position : The key can be removed in this position.
All the electric systems are switched off. To shut down the engine, move the key to this position.
- I position : The charging circuit and lamp circuit are charged with electricity. Leave the key in this position after the engine has started.
- 🔑 position : The engine is cranked and gets started. The moment the engine has started, release the key. It will automatically return to the “I” position.

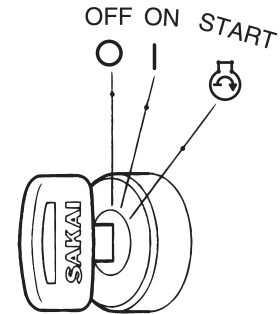

⚠ CAUTION

Set the F-N-R lever in the neutral position (N) and press down the parking brake switch before starting the engine. Unless these conditions are met, the engine will not start.

Parking brake switch

Use it as a parking brake.

Do not use while the machine is moving.

If switch (P) is pressed down, the parking brake will be applied with the indicator lamp (P) on the dashboard lit up. When pressed again, the brake is released and the indicator lamp goes off.

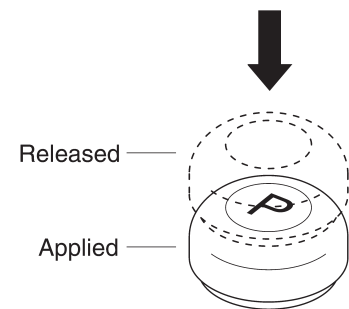

⚠ WARNING

- To disengage the brake, be sure to press the button again instead of pulling it.
- When dismounting from the machine, press the switch to apply the brake without fail.

⚠ CAUTION

Never pull the switch up.

Horn switch button

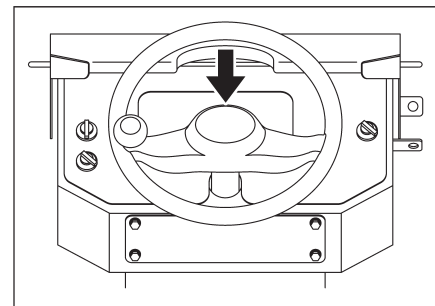

Pressing the button at the center of the steering wheel sounds the horn.



2 OPERATION

Vibrator switch

By means of vibrator switch located on the panel, selection of vibration amplitude and On-Off is mode.

-  position : Turning the vibrator switch clockwise causes the vibration to start with high amplitude.
-  position : Vibration is shut down.
-  position : Turning the vibrator switch counter clockwise causes vibration to start with low amplitude.

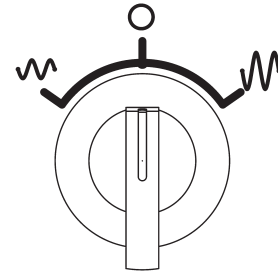

NOTE : For Vibratory rolling, run the engine at FULL and ECO.





Vibrator switch

Vibration selector switch

Selection can be mode between the vibrator switch installed to the F-N-R lever and the other one located on the panel.

-  position : Vibration can be turned ON or OFF with the switch located on the F-N-R lever. Pressing this switch causes the vibration to start and pressing it again to stop. This vibration switch on the lever should be used with the vibrator switch on the panel placed at  or  position.

CONT position : When the vibrator switch is set to the  or  position, you can perform vibration work without turning the vibration switch ON and OFF.

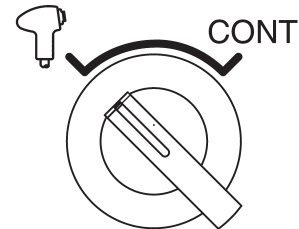

Vibration selector switch

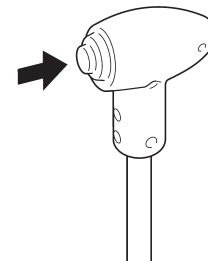

Vibration switch



IMPORTANT

- Do not operate the vibrator on a hard area such as cement concrete pavement surface or the ground covered by thick steel sheets.
- Keep the vibrator stopped when the machine is at rest.
- Shut off the vibrator immediately when the machine has been caught in the mud during vibratory operation.

NOTE : For vibratory rolling, run the engine at FULL and ECO.

Travel mode switch

Selects three machine speed ranges.

	 1st	2nd	 3rd
Speed	0 – 4 (0 – 2.5)	0 – 6 (0 – 3.7)	0 – 10 (0 – 6.2)

km/h (mile/h)

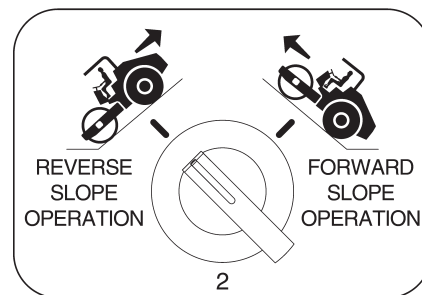

FORWARD SLOPE OPERATION  and REVERSE SLOPE OPERATION  can be selected in 2nd of Travel mode switch. It can not be selected with  (1st) and  (3rd).

FORWARD SLOPE OPERATION  is suitable for climbing uphill in forward.

REVERSE SLOPE OPERATION  is suitable for climbing uphill in reverse.

Please choose according to the situation of the work site.

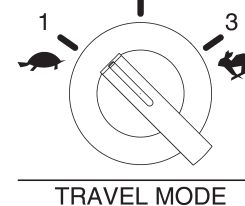

Travel mode switch

IMPORTANT

- **Be sure to shift gears while the machine is being stopped. Do not shift gears during running.**
- **Setting the traction control switch according to the uphill direction while driving the machine on a hill will automatically control the front and rear wheels to prevent slipping.**

Engine speed select switch

Shifts the engine RPM.

	IDLE	ECO	FULL
Engine speed	900 min ⁻¹	1850 min ⁻¹	2200 min ⁻¹

(± 50 min⁻¹)

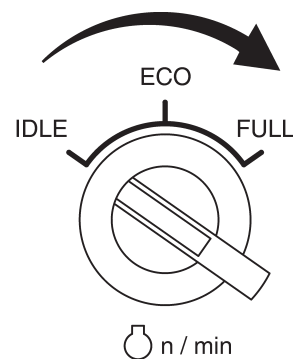

Engine speed select switch

2 OPERATION

Manual regeneration switch

Press the  switch to start parked manual regeneration. Press the switch again to stop parked manual regeneration.

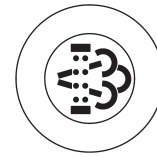

MANUAL
REGEN.

Disable regeneration switch

Use to disable / enable regeneration.

- (OFF) position : Enables regeneration, and the disable regeneration lamp turns off.
- ┆ (ON) position : Disables regeneration, and the disable regeneration lamp turns on.



DISABLE
REGEN.

2.1.4 Operating levers / pedals

Forward-Neutral-Reverse (F-N-R) lever

Moving the F-N-R lever forward or backward makes the machine travel forward or backward respectively. The neutral position (N) brings the machine to a stop. The machine speed increases or decreases in proportion to the lever displacement.

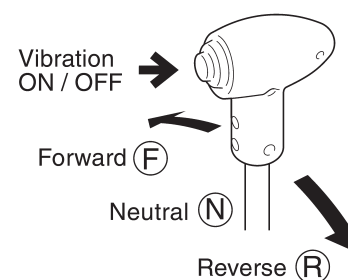

Provided at the knob of the lever is the vibration switch for turning on or off the vibration.

IMPORTANT

- For normal braking, return the F-N-R lever back to neutral.
- In an emergency, depress the brake pedal.

Leveling blade lift lever (SV544TB, SV544FB)

The leveling blade is operated from a single control lever. The lever has four positions; RAISE, HOLD, LOWER and FLOAT.

Raise : To raise the blade, pull the lever backward. The lever automatically returns to the Hold position when released.

Hold : When this position is selected, the blade stays in any position.

Lower : To lower the blade, push the lever forward. The lever automatically returns to the Hold position when released.

Float : Push the lever forward to its full extent. In this position, the blade becomes free to ride up and down over the ground, following the ground configuration as the machine travels. The lever stays in the Float position even if it is released.

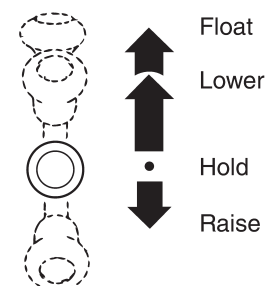

Brake pedal

Use it in emergencies. Carry out inspections in accordance with “3.3 Periodical Maintenance Points” (refer to page 86) after each use.

In an emergency, push down on the pedal to the full extent, and the machine will come to a sudden stop.

IMPORTANT

- Do not use the pedal wherever practicable except for an emergency.
- The F-N-R lever permits usual braking.

NOTE: After depressing the brake pedal, return the F-N-R lever to the (N) position, otherwise the machine will not start.

2 OPERATION

2.1.5 Unloader valve

The unloader valve disengages the drive, playing a role like a clutch. Use this valve for towing the machine when the engine is disabled or when troubles have developed in the hydraulic drive.

Towing Speed:

At or less than 0.5 km/h (0.3 mile/h)

Towing Distances : Within 100 m (328 ft)

For towing:

Turn the knob counterclockwise (Unload).

For normal traveling:

Turn the knob clockwise (Onload).

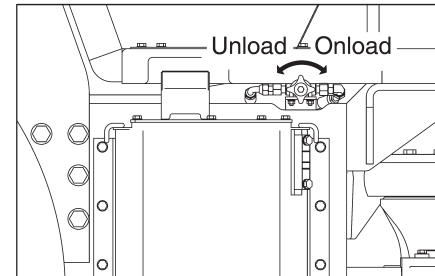
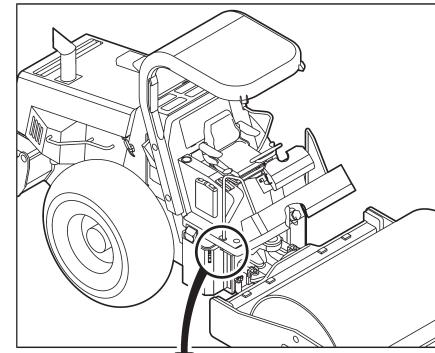

⚠ WARNING

- **On a slope, chock the wheels and use extreme care when handling the unloader valve and towing the machine.**
- **Be sure to apply the parking brake when operating the unloader valve.**
- **Unloading the unload valve will disengage the engine, so never get in front of or behind the machine.**

NOTE: For normal travel, be sure to close the unloader in the ONLOAD position.

2.1.6 Fuse box and line fuse

⚠ WARNING

When changing a fuse, cut the power supply by turning the starter switch to the **O** position.

The fuse box is located at the back of the driver's seat.

Recline the back of the seat towards the front, turn the stud in a counterclockwise direction by 90 degrees, and then open the panel cover.

The line fuses are located inside the box behind the driver's seat on the left rear side of the machine. Open the panel cover, then the box cover.

Fuses protect electrical components and wiring from burning. Change any fuse which has become powder-coated due to deterioration or which has play between it and fuse holder. To replace fuses, take off the cover. Be sure to use fuses of correct capacity.

Using improperly rated fuses may result in poor machine performance, damage to the electrical system, or safety problems, such as an electrical fire.

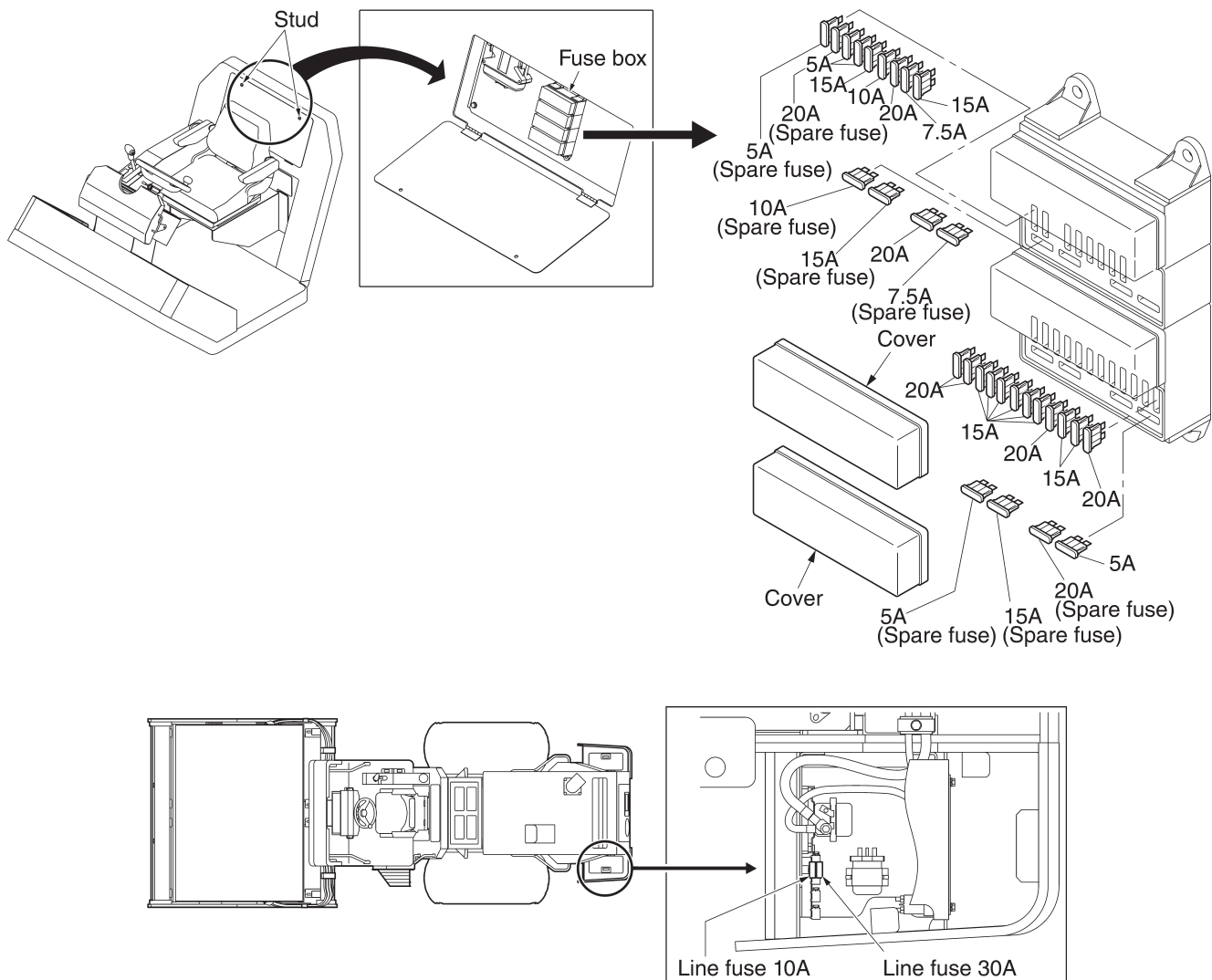

2 OPERATION

2.2 Handling and Adjustments

2.2.1 Seat adjustment

Adjust the seat for your best operating position. Move the lever as shown by arrow. With the lever held in that position, slide the seat forward or backward as desired. When properly adjusted, release the lever.

Adjust your seat position to suit you as follows:

- 1) Pull the lever ① and adjust seat position longitudinally.
- 2) Turn the backrest adjust dial ② for optimum angle.
- 3) Move the suspension lever ③ to select suitable suspension for your body weight.

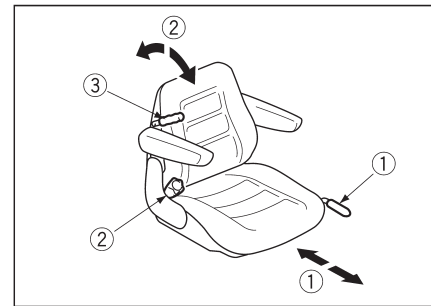

⚠ WARNING

- **The seat shall be adjusted before starting any works or when the driver is switched over the other person while the machine is completely stopped. Do NOT adjust the seat while the machine is in motion.**
- **Some unexpected troubles may be accidentally caused if moving the machine without completely fixing the seat such as while sliding the seat. Before moving the machine, make certain that the seat is completely fixed after making proper adjustments.**
- **Do not pinch your fingers, hands or legs while adjusting the seat.**
- **Adjust seat only when one person rides on the machine.**
- **Adjust seat only when the machine stays on the flat ground.**
- **Adjust the seat so that your back is in close contact with the back of the seat while seated and when stepping on the brake pedal down to the floor. Adjust the seat so as to be able to certainly step on the brake pedal when twisting your body around to look back in order to move the machine backwards.**

IMPORTANT

Be sure to wear the seatbelt during operation.

2.2.2 Scraper replacement and adjustment

SV544D, SV544TF, SV544FB

1) Clearance adjustment of scraper (A)

- ① Loosen bolts and nuts (B) at 8 locations.
- ② Provide a clearance of 20 mm between scraper blades (A) and the drum.
- ③ Retighten bolts and nuts (B) at 8 locations.

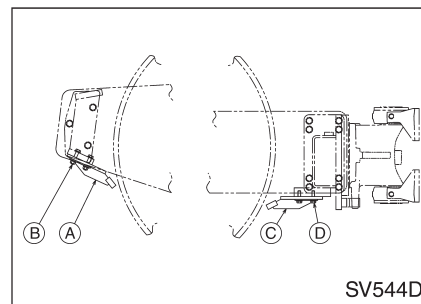

2) Clearance adjustment of scraper (C)

- ① Loosen bolts (D) at 8 locations.
- ② Provide a clearance of 20 mm between scraper blades (C) and the drum.
- ③ Retighten bolts (D) at 8 locations.

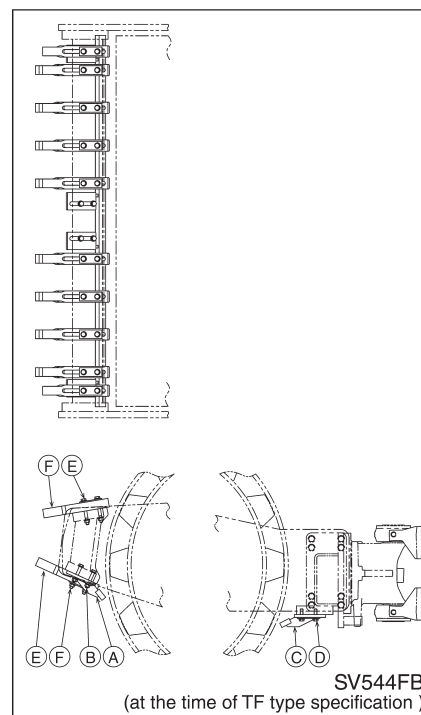
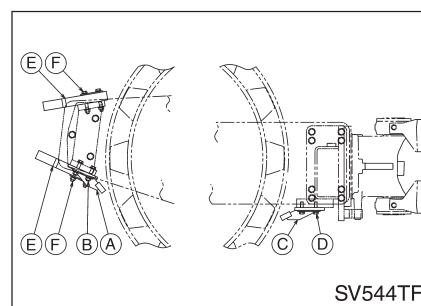

2 OPERATION

3) Change from TF to T types

- ① Loosen bolts and nuts (B) at 8 locations.
- ② Adjust the scraper blade (A) by changing its direction so that it does not interfere the pads.
- ③ Retighten bolts and nuts (B) at 8 locations.
- ④ Loosen bolts (D) at 8 locations.
- ⑤ Adjust the scraper blade (C) so that it does not interfere the pads.
- ⑥ Retighten bolts (D) at 8 locations.
- ⑦ Loosen bolts and nuts (F) at 18 locations.
- ⑧ Adjust the scraper blade (E) by changing provide a clearance of 20 mm between scraper (E) and the drum.
- ⑨ Retighten bolts and nuts (F) at 18 locations.

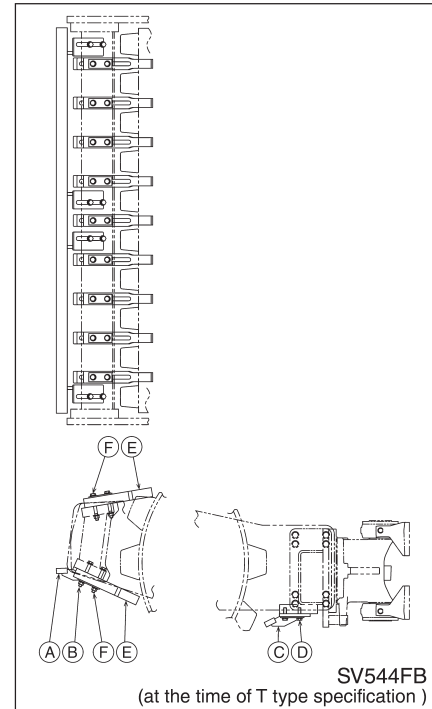
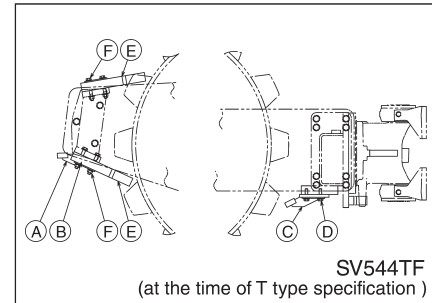

SV544T, SV544DF, SV544TB

1) Clearance adjustment of scraper (A)

(Nine pieces are mounted on both the top surface and the undersurface for each in front of the machine).

- ① Loosen bolts and nuts (B) at 18 locations.
- ② Provide a clearance of 20 mm between scraper (A) and the drum.
- ③ Retighten bolts and nuts (B) at 18 locations.

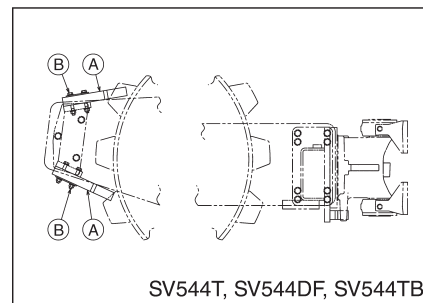

2) Replacement of scraper (A)

(Nine pieces are mounted on both the top surface and the undersurface for each in front of the machine).

- ① Remove bolts and nuts (B).
- ② Replace scraper (A) with new ones.

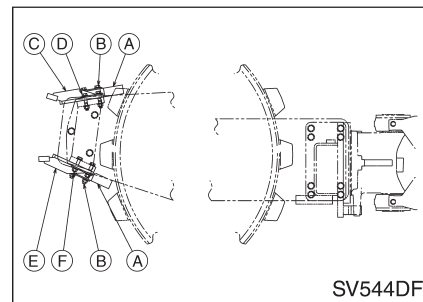

3) Change from DF to D types

- ① Loosen bolts and nuts (B) at 18 locations.
- ② Adjust the scraper blade (A) by changing its direction so that it does not interfere the pads.
- ③ Retighten bolts and nuts (B) at 18 locations.
- ④ Loosen bolts and nuts (D) at 8 locations.
- ⑤ Move the scraper blade (C) to the undersurface at the rear of the frame such that there is a gap by 20 mm between the scraper blade (C) and the drum.
- ⑥ Retighten bolts (D) at 8 locations.
- ⑦ Loosen bolts and nuts (F) at 8 locations.
- ⑧ Adjust the scraper blade (E) by changing provide a clearance of 20 mm between scraper (E) and the drum.
- ⑨ Retighten bolts and nuts (F) at 8 locations.

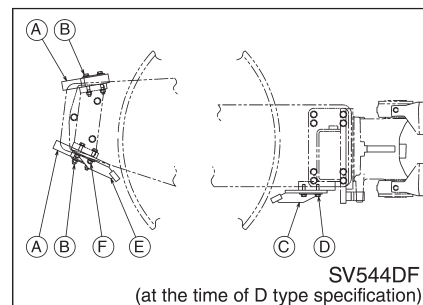

2 OPERATION

2.2.3 How to replace the shells

Operating the crane to replace the shells.

⚠ WARNING

- The person responsible for hoisting and lowering the shells using a crane must be legally qualified to do so.
- Use a wire rope of adequate strength when hoisting the shells.
- Be sure to attach the wires to the hooks firmly as shown in the diagram.
- Check the balance before hoisting and lowering.

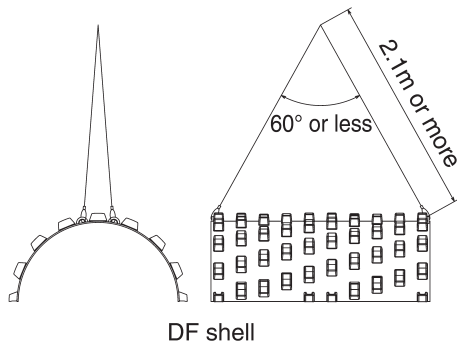

DF shell

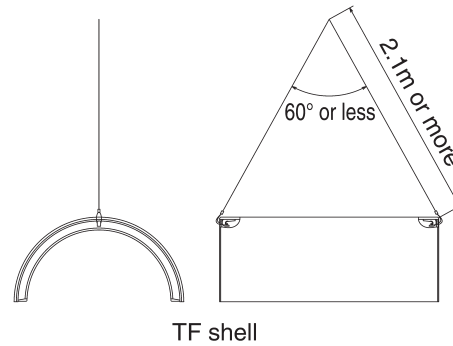

TF shell

SV544DF

1) Removing the shells

- ① Remove the scrapers (A), (B), (C) and (D).

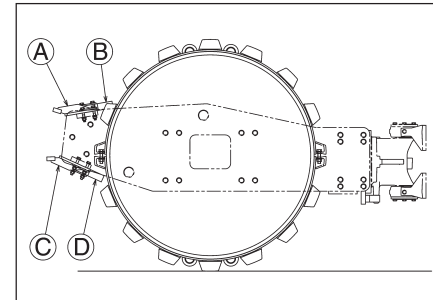

- ② Use screw clamps (G) to fix the shells (E) and (F) onto the roller at eight locations.

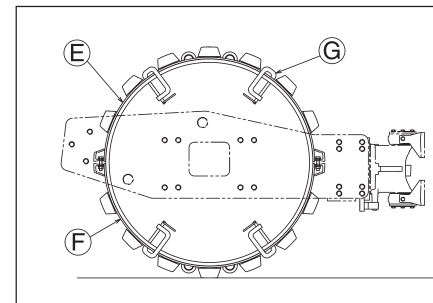

- ③ Make sure the screw clamps do not bite into the frame while rotating the roller as shown in the diagram to make it easier to loosen the nuts and bolts ④, then remove them ④ (from eight locations).

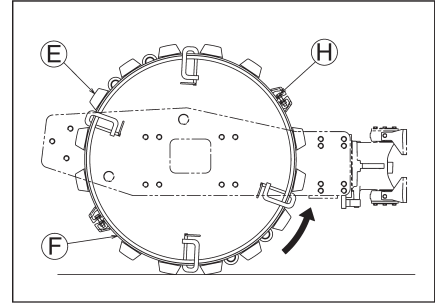

- ④ Make sure the screw clamps do not bite into the frame while rotating the roller so that the split surfaces of shells ⑤ and ⑥ are parallel to the ground as shown in the diagram.

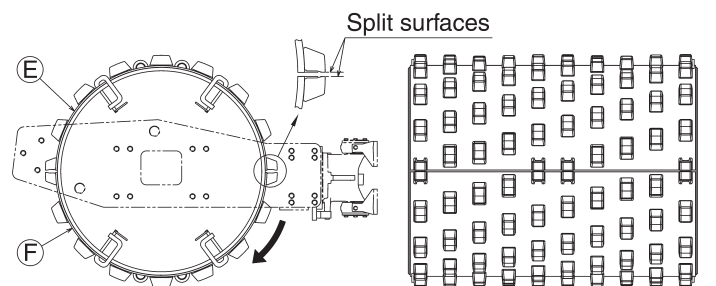

- ⑤ Remove the screw clamps holding down shell ⑤, and hoist shell ⑤ using a crane to remove it. The shell weighs 770 kg (1,700 lbs).

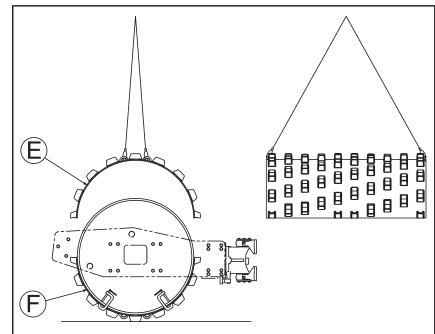

- ⑥ Make sure the screw clamps do not bite into the frame while rotating the roller into a position that will allow the hoisting of shell ⑥ using a crane.

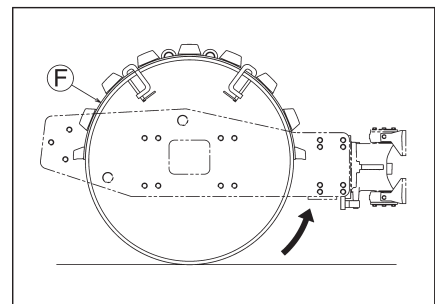

2 OPERATION

- Remove the screw clamps holding down shell (F), and hoist shell (F) using a crane to remove it.

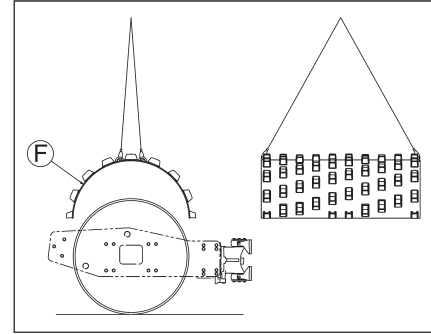

- Attach scrapers (A), (B), (C) and (D) (to attach the scrapers, refer to section “2.2.2 Scraper replacement and adjustment”). Safely store the removed shells.

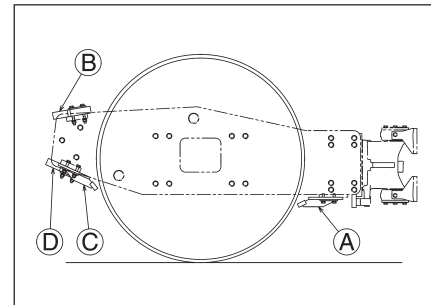

2) Attaching the shells

- Remove the scrapers (A), (B), (C) and (D).

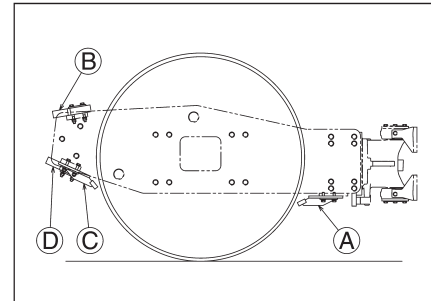

- Clean the contact surfaces of the shells and roller, then use a crane to hoist shell (F), and lower it onto the roller.

The shell weighs 770 kg (1,700 lbs).

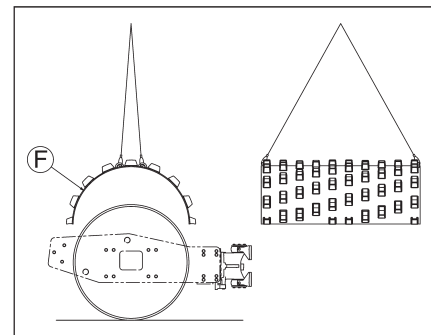

- ③ Lower shell ⑥ onto the center of the roller, and fix it in position using screw clamps ⑦ at four locations.

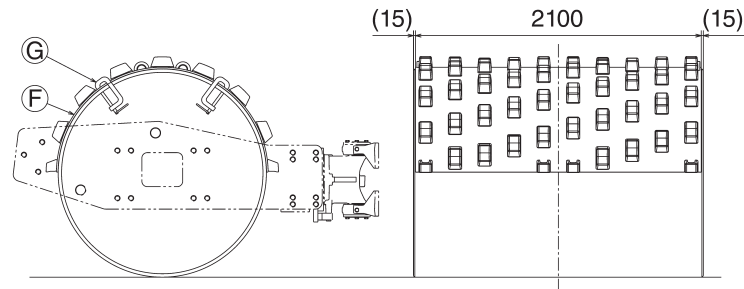

- ④ Make sure the screw clamps do not bite into the frame while rotating the roller so that shell ⑥ is directly below the roller.

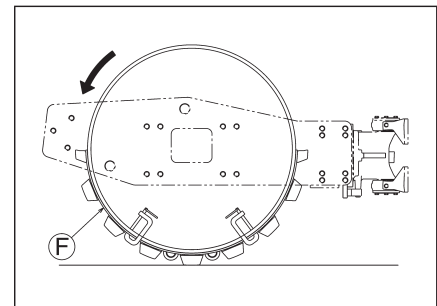

- ⑤ Hoist shell ⑤, and lower it onto the roller.

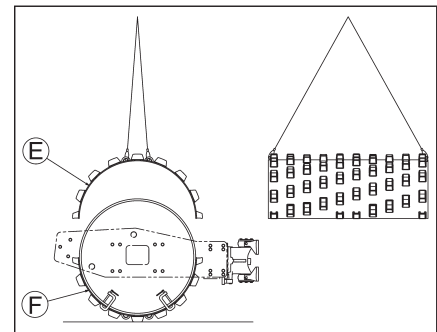

- ⑥ Align the edges of shell ⑤ with the edges of shell ⑥, and adjust it so that the gaps between the shells are the same on both sides.

- ⑦ Fix shell ⑤ in position using screw clamps ⑦ at four locations.

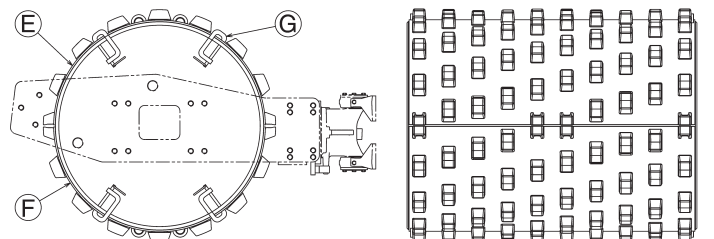

2 OPERATION

- ⑧ Make sure the screw clamps do not bite into the frame while rotating the roller as shown in the diagram to make it easier to attach the nuts and bolts ④, then attach (at eight locations) and tighten them ④ with a tightening torque of 539 N·m.

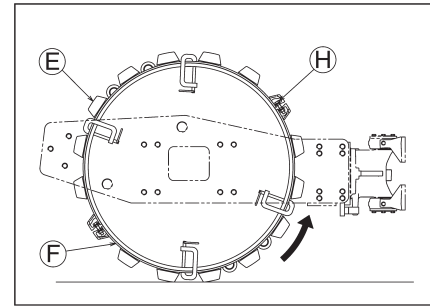

- ⑨ Remove the screw clamps and attach scrapers ①, ②, ③ and ④ (to attach the scrapers, refer to section “2.2.2 Scraper replacement and adjustment”).

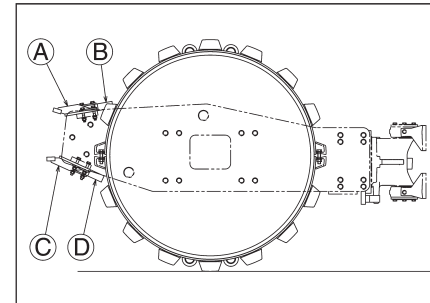

SV544TF

⚠ WARNING

- Worn shells that have been used for a long time may become warped. If they are, stop using them immediately, and replace them with new ones.
- The split sections between the shells may emit some metallic noise while running, but this is not a quality issue.

1) Removing the shells

- ① Remove the scrapers ①, ②, and ③.

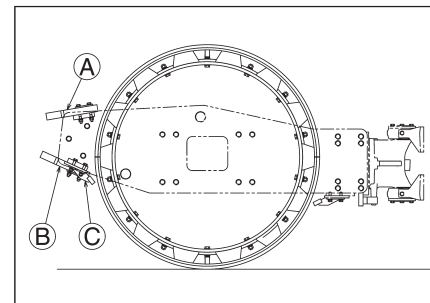

- ② Rotate the roller so that the split surfaces of shells ④ and ⑤ are perpendicular to the ground, then remove the nuts and bolts ⑥ (from eight locations).

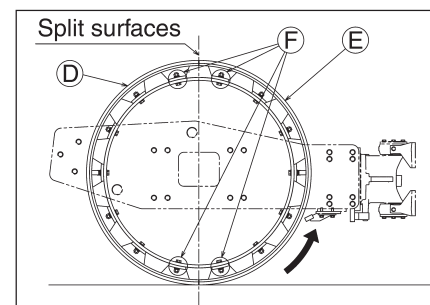

- ③ Rotate the roller so that the split surfaces of shells ① and ② are parallel to the ground, then remove the nuts and bolts ③ on shell ① (from ten locations).

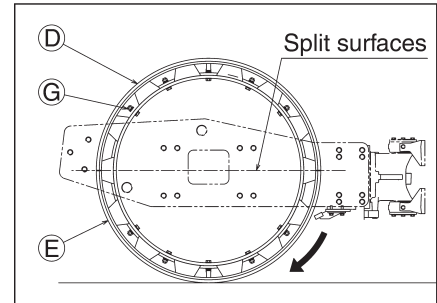

- ④ Hoist shell ① using a crane to remove it. The shell weighs 1,090 kg (2,405 lbs).

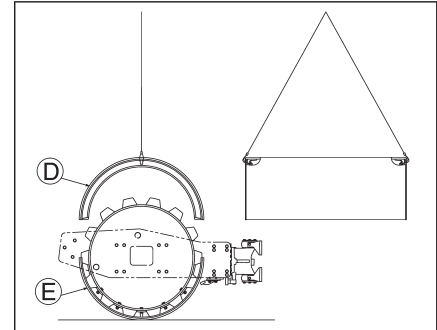

- ⑤ Rotate the roller so that the suspension hooks on shell ② are positioned at the top of the roller, then remove the nuts and bolts ④ (from ten locations).

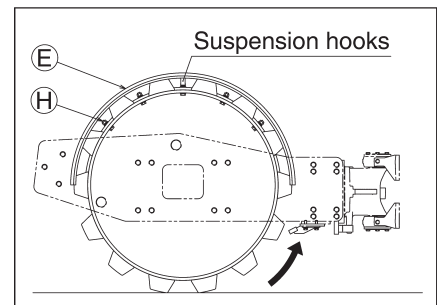

- ⑥ Hoist shell ② using a crane to remove it.

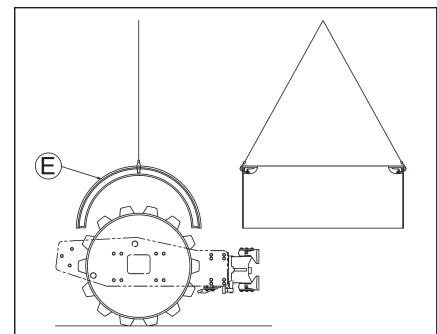

2 OPERATION

- ⑦ Attach scrapers (A), (B), and (C) (to attach the scrapers, refer to section “2.2.2 Scraper replacement and adjustment”). Safely store the removed shells.

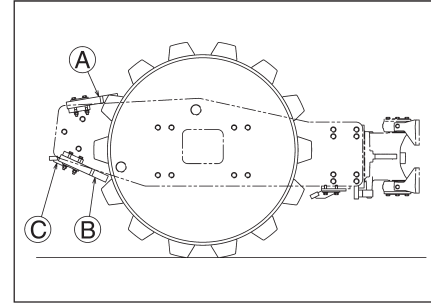

2) Attaching the shells

- ① Rotate the roller so that the shell attachment hole of your choice is positioned at the top of the roller.

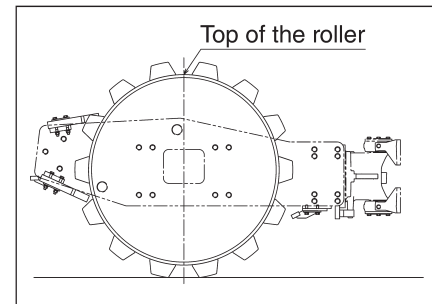

- ② Remove the scrapers (A), (B), and (C).

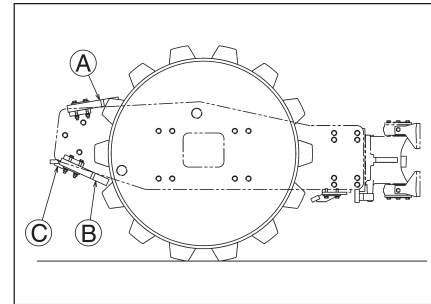

- ③ Clean the contact surfaces of the shells and roller, then use a crane to hoist shell (E), and lower it onto the roller.
The shell weighs 1,090 kg (2,405 lbs).

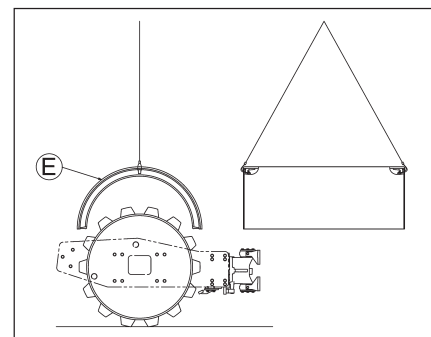

- ④ Align the edge of shell ⑤ with the edge of the roller, then attach and tighten the nuts and bolts ⑥ (at ten locations) with a tightening torque of 539 N·m.

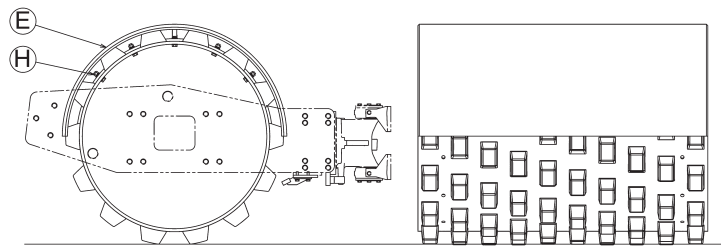

- ⑤ Rotate the roller so that the suspension hooks on shell ⑤ are positioned at the bottom of the roller.

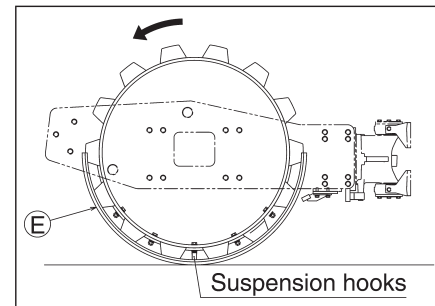

- ⑥ Hoist shell ⑦, and lower it onto the roller.

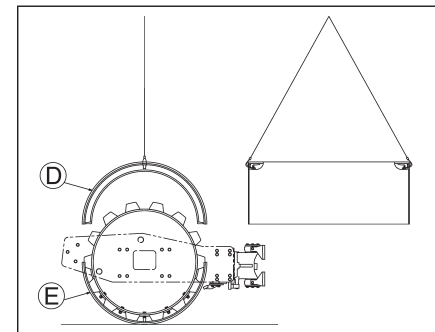

- ⑦ Align the edges of shell ⑦ with the edges of shell ⑤, and adjust it so that the gaps between the shells are the same on both sides.

- ⑧ Attach and tighten the nuts and bolts ⑧ (at ten locations) with a tightening torque of 539 N·m.

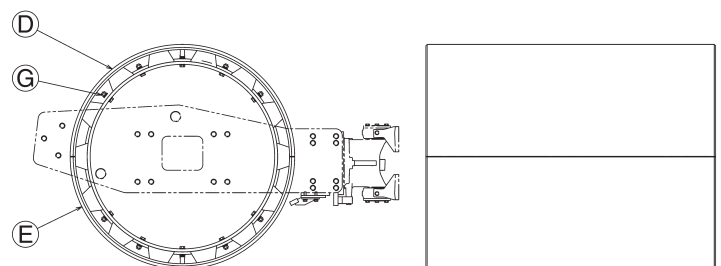

2 OPERATION

- ⑨ Rotate the roller so that the split surfaces of shells ④ and ⑤ are perpendicular to the ground, then attach and tighten the nuts and bolts ⑥ (at eight locations) with a tightening torque of 539 N·m.

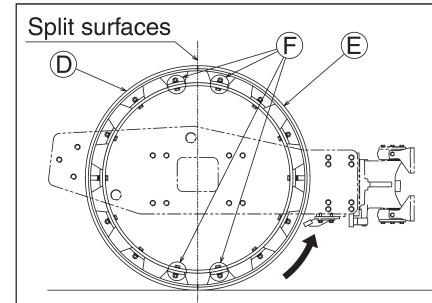

- ⑩ Attach scrapers ①, ②, and ③ (to attach the scrapers, refer to section "2.2.2 Scraper replacement and adjustment").

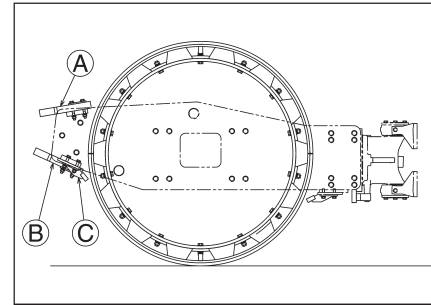

2.2.4 Disengaging the brake when towing

⚠ WARNING

- On a slope, chock the drums and prepare for towing before disengaging the brake.
- Avoid a long-distance towing.

For towing the machine when the engine is disabled or when trouble has developed in the hydraulic propulsion, system disengage the brake as instructed below:

- 1) Loosen ③ : lock ring of ② : selector valve counterclockwise. And turn ② counterclockwise.
- 2) Turn the unloader valve counterclockwise to release it.
Refer to “Unloader valve” on page 38 for its operation method.
- 3) Pull up and press the ① : knob of the pump slowly. The brake can be released by pressing it about 35 times. When the operation force is felt heavy, the brake is released. Stop the operation at that time. Continued operation may cause damage to the machine.
- 4) Turn the unloader valve clockwise to engage the drive. Refer to “Unloader valve” on page 38 for its operation method.
- 5) After towing is completed, turn ② clockwise until it stops. And fix ② with the ③ .

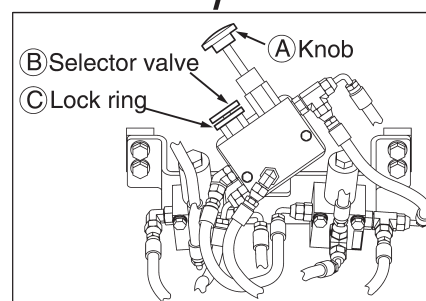
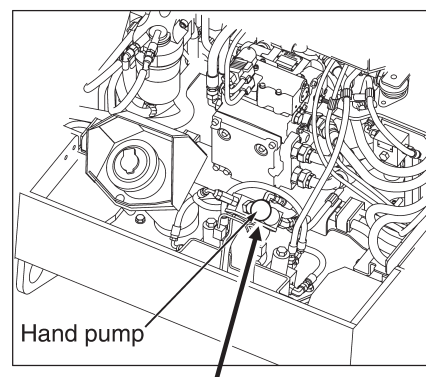

⚠ WARNING

- Do not try to release the brake immediately after a hot engine has been stopped. Let the oil cool down.
- For the brake disengagement, wear hard hat, safety goggles and safety gloves.



2 OPERATION

2.2.5 Engine troubleshooting

Engine troubleshooting can be conducted using the trouble code selector switch.

During normal operation, do not operate switches.

Set switch as shown in the figure during the normal operation.

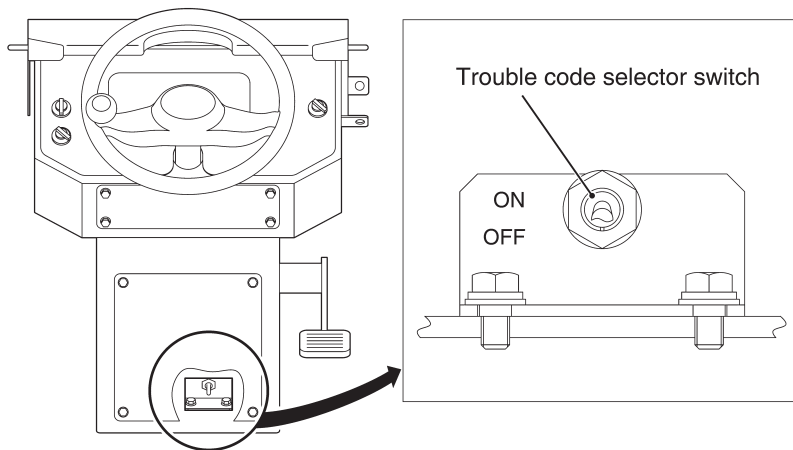

IMPORTANT

When operating the trouble code selector switch, see the engine manual.

2.3 Operation

⚠ WARNING

- This machine is a one-man roller.
- Operate the machine from the operator's seat.
- Be sure to wear the seatbelt during operation.

2.3.1 Before-starting inspection

1) Check that the steering lock pin is in the carrying position.

⚠ WARNING

Make sure that the steering lock pin is in the carrying position before putting the machine in motion. Steering is impossible if the pin is in the steering lock position.

The pin is located at the right of the center of the machine.
To unlock the pin.

- ① Pull out the lock pin.
- ② Set the pin in the carrying position.

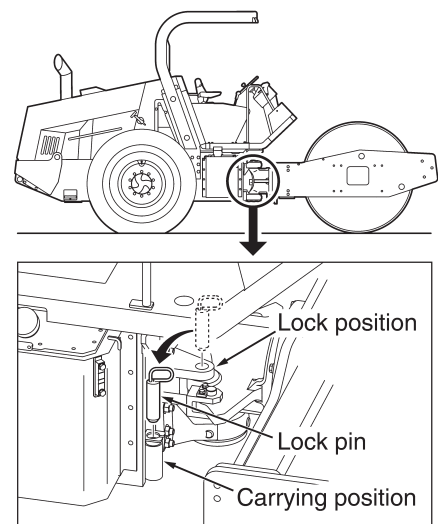

2) Check that the F-N-R lever and is in the neutral position (N) .

3) Confirm that the parking brake is engaged.

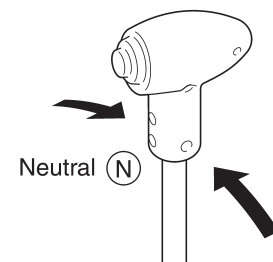

NOTE: When the F-N-R lever is not in the neutral position (N) , or the parking brake has been released, the interlocking system goes into operation and the engine will not turn on. Be sure to confirm that the F-N-R lever is in the neutral position (N) , and that the parking brake is engaged before starting the engine.

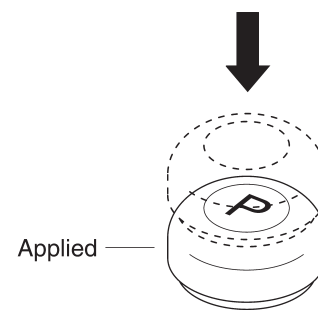

2 OPERATION

2.3.2 Starting the engine

⚠ WARNING

- Sound the horn when starting the engine after making certain that there are no one and no objects close to the machine.
- After making certain that the parking brake is effectively pushed, and shifting the F-N-R lever to the neutral position (N), then start the engine.

1) Set the engine speed select switch in the IDLE position.

(± 50 min⁻¹)

Engine speed	IDLE	ECO	FULL
	900 min ⁻¹	1850 min ⁻¹	2200 min ⁻¹

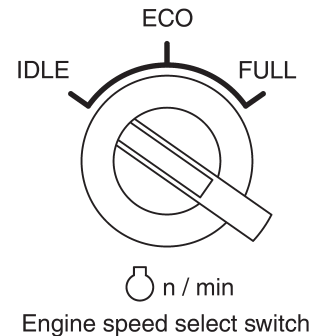

2) Turn the starter switch to the “I” position and check that the warning lamps and parking brake indicator lamp on the monitor display are on.

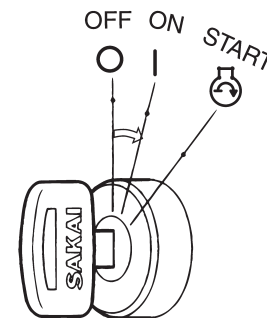
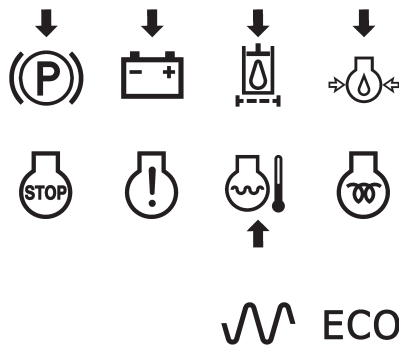

3) Start the engine after the engine check lamp lights up and goes out.

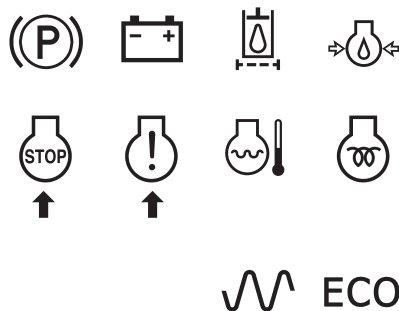

Wait to start

LCD monitor display

- 4) Turning the key to the  position makes the engine start. Release the key the moment the engine has started. The key will automatically return to the **I** position.

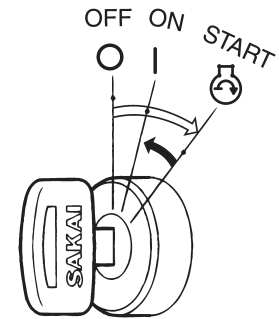

⚠ CAUTION

- Do not allow the starter key to stay in the  position for more than 15 seconds.
- When the engine fails to start, or you want to restart the engine immediately after turning it off, wait around 30 seconds before restarting it.
- If the engine does not start, allow an interval before trying again.
- Check that the warning lamps on the monitor display go off immediately after the engine is started. If any of these warning lamps stay on while the engine is running, shut down the machine, determine the cause and rectify the fault.

2.3.3 After starting the engine

Try not to move the machine immediately after starting but practice the following:

IMPORTANT

Avoid increasing the engine speed abruptly before warming-up run is completed.

- 1) Run the engine at idling for about 5 minutes to warm it up. Warming-up run allows the lubricating oil to reach the vital parts of the engine and hydraulic system, gradually warm the engine, engine oil and hydraulic oil to prepare the machine for driving.
- 2) After the warm-up operation, check that:
 - Temperature gauge Pointer falls near the center zone
 - Fuel gauge Pointer falls between the E and F marks
 - Charge lamp..... Has gone off
 - Engine oil pressure warning lamp ... Has gone off
 - Engine check lamp..... Has gone off
- 3) Check for the color of exhaust gas, listen for unusual sounds and vibration. If abnormal, determine the cause and correct the problem.

⚠ WARNING

Keep staying at the driver's seat while starting the engine.

2 OPERATION

2.3.4 Traveling



⚠ WARNING

- When starting, operate the horn after securing the safety around the machine.
- Be sure to wear the seatbelt during operation.

⚠ CAUTION

While travelling, do not turn the starter switch \bigcirc position.

1) Select the desired speed by the speed change switch.

	1 	2	3 
Speed	0 – 4 (0 – 2.5)	0 – 6 (0 – 3.7)	0 – 10 (0 – 6.2)

km/h (mile/h)

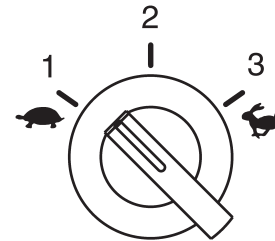

Speed change switch

⚠ WARNING

- On a steep slope, run the machine at low speed.
- Do not attempt to shift speed while travelling.

IMPORTANT

Be sure to shift gears while the machine is stopped. Can not shift gears during running.

2) Turn the engine speed select switch to increase the engine speed.

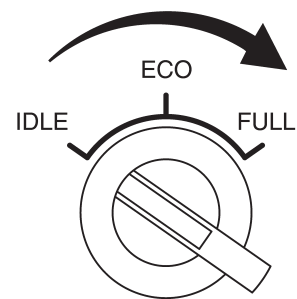

 n / min
Engine speed select switch

3) Press down the parking brake switch button to release the brake. Check that indicator lamp (P) on the monitor display goes off.

CAUTION
Never pull the switch.

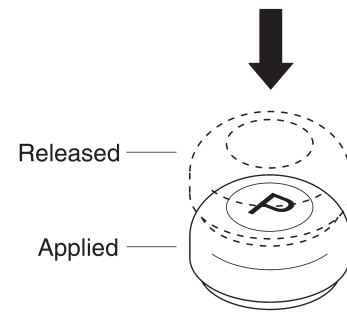

4) Move the F-N-R lever in the direction to travel, and the machine will begin traveling.

CAUTION
Avoid abrupt operation of the F-N-R lever.

NOTE: The travel speed can be controlled by the engine speed select switch and F-N-R lever.

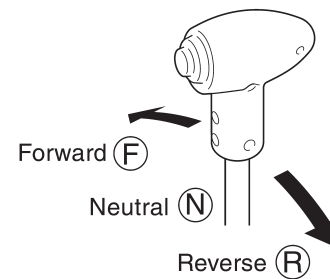

WARNING
Pay extreme attention to the area behind the machine when backing, since the space just behind it tends to be a blind spot.

2 OPERATION

2.3.5 Stopping / Parking

⚠ WARNING

- **Avoid abrupt braking. Leave enough space for braking safety.**
- **Avoid parking on a grade.**
- **If necessary to park on a grade, chock the drum and tires to prevent unexpected moving down the grade.**

1) Bring the F-N-R lever to the neutral position (N), and the machine will come to a halt.

⚠ CAUTION

- **For normal braking, move the F-N-R lever back to the neutral position.**
- **In an emergency, depress the brake pedal.**

IMPORTANT

After depressing the brake pedal, return the F-N-R lever to the (N) position, otherwise the machine will not start.

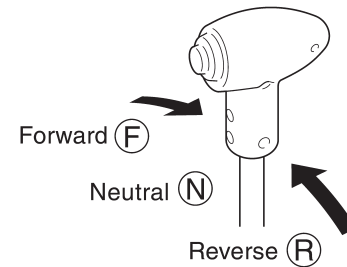

2) Press the parking brake switch button securely, and check that indicator lamp (P) illuminates.

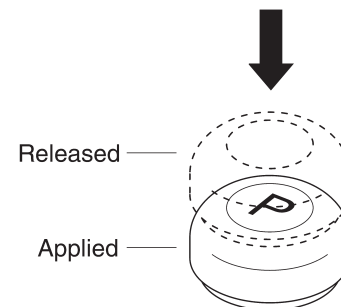

2.3.6 Stopping the engine

- 1) Set the engine speed select switch at the IDLE position, wait for about 5 minutes with the engine idling to gradually cool the engine.

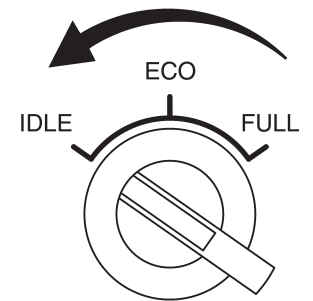

Engine speed select switch

IMPORTANT

- Do not bring a hot engine to a sudden stop except for an emergency. This will shorten the life of its component parts.
- Do not also allow an overheated engine to come to a sudden stop, but run it at middle idling speed for gradual cooling down.

- 2) Turn the starter key to the ○ position to stop the engine.

CAUTION

Do not turn the starter switch ○ position while the machine is in motion.

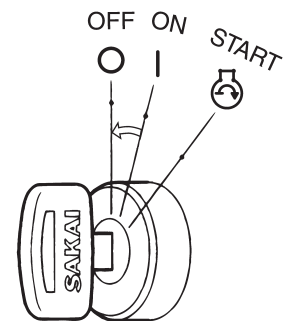

- 3) Remove the starter key.

WARNING

- When dismounting from the machine, apply the brake by pressing the parking brake switch button. If necessary to park on a grade, block the wheels to prevent unexpected moving down the grade.
- Never fail to remove the starter key.

2.3.7 Check after stopping the engine

- 1) Perform the walk-around checks for oil and water leakage, abnormal signs around the drums.
- 2) Fill the fuel tank.
- 3) Remove waste paper if any from the engine compartment, as this will pose a possible fire hazard.
- 4) Scrape mud or other materials from and around the drums.
- 5) When transporting the machines, please ensure safety by strictly complying with the applicable laws and regulations.

2.4 Vibratory Operation

- 1) Turn the engine speed select switch clockwise to set the engine RPM to FULL or ECO.

NOTE: It is possible to conduct the rolling compactions as much as the vibration specifications when setting the engine speed select switch to FULL and ECO. MID is fuel-efficient position called the ECO MODE.

The ECO MODE is recommended when working on flat road surfaces as the maximum speeds and the hill-climbing performances are degraded. Please conduct the rolling compactions by setting to the FULL position when working on soft, steep sloped and rugged road surfaces.

- 2) Use the vibrator switch [Ⓐ] installed at the control panel on the top of the dashboard to select low or high amplitude and ON / OFF of vibration.



- ⚡ position : Turning the vibration switch clockwise causes the vibration to start with high amplitude.
- position : Vibration is shut down.
- ⚡ position : Turning the vibrator switch counter clockwise causes vibration to start with low amplitude.

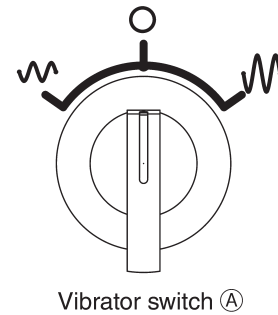
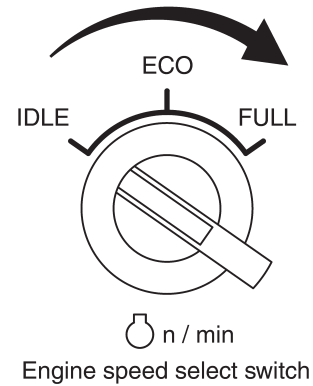

NOTE: For vibratory rolling, run the engine at FULL. or ECO.



Vibration can be turned ON / OFF with the vibration switch ③. Select a suitable setting depending on a working site condition.

 position : Vibration can be turned ON or OFF with the switch located on the F-N-R lever. Pressing this switch causes the vibration to start and pressing it again to stop.

This vibration switch on the lever should be used with the vibrator switch on the panel placed at  or  position.

CONT position : When the vibrator switch is set to the  or  position, you can perform vibration work without turning the vibration switch ON and OFF.

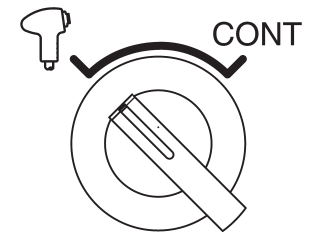

Vibration selector switch ②

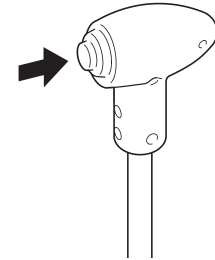

Vibration switch ③

3) Proper travel speed for vibratory compaction is 2 – 5 km/h (1.2 – 3.1 mile/h), however, select speeds depending upon job requirements.

IMPORTANT

- **Keep the vibrator shut off when the machine is not rolling.**
- **Stop vibration if the machine has encountered a running difficulty, for example, when it gets stuck in the mud.**
- **Set the speed change switch in the 1st, 2nd speed position during vibratory rolling compaction. Use the 3rd speed position only for driving on flat straight roads.**

2.5 Operating the DEF SCR System

1) About the DEF SCR (Selective Catalytic Reduction) system

The DEF SCR system breaks down toxic nitrogen oxides (NOx) contained in the exhaust gas into harmless nitrogen and water. DEF is sprayed into the exhaust gas, and the ammonia generated by the urea reacts with the nitrogen oxides breaking them down into nitrogen and water.

Depending on the operating conditions, when the DEF SCR system's cleaning function deteriorates, regeneration is carried out to protect the system.

CAUTION

- **Keep the DEF tank topped up by refilling it at the right time.**
- **Always use the DEF designated by our company.**

2) Regeneration

Regeneration is carried out in the following ways.

- Automatic regeneration



The exhaust equipment high temperature lamp  will turn on.

NOTE: The machine may be driven or operated as usual during automatic regeneration.

- Parked manual regeneration request

Parked manual regeneration lamp / Regeneration lamp  will turn on.



Press the Parked manual regeneration switch  in accordance with the prescribed procedures.

The exhaust equipment high temperature lamp  will turn on when regeneration begins, and the parked manual regeneration lamp / regeneration lamp  will flash.

- Parked manual regeneration request emergency lamp  will flash.

Parked manual regeneration lamp / Regeneration lamp  will turn on.

Press the Parked manual regeneration switch  in accordance with the prescribed procedures.

The exhaust equipment high temperature lamp  will turn on when regeneration begins, and the parked manual regeneration lamp / regeneration lamp  will flash.

NOTE: The engine sound, exhaust gas smell, etc., may change during regeneration.

⚠ WARNING

- **Do not carry out cleaning in enclosed spaces with poor ventilation, such as inside a garage or a room. There is the danger of carbon monoxide poisoning.**
- **Check to make sure there are no flammables near the mouth of the exhaust pipe to prevent fires.**
- **Do not touch or let people go near the exhaust pipe or muffler, which will be hot during cleaning, and for a while after cleaning.**

3) Procedures for parked manual regeneration

- ① Turn off the vibrator.
- ② Move the machine to a safe place.
(The exhaust gas temperature will rise during parked manual regeneration, so beware of burns, trees lining streets, fires, ventilation, etc.)
- ③ Move all F-N-R levers to the neutral position.
- ④ Press the parking brake switch.
- ⑤ Let the engine idle.
- ⑥ Check to make sure that the disable regeneration lamp is turned off.
- ⑦ Press the parked manual regeneration switch.
(Regeneration is complete when all the indicator lamps turn off. Be sure to let the engine idle for 5 minutes after completion of regeneration)
*If the thermometer is in the position (C) before carrying out parked manual regeneration, let the engine warm up.

⚠ CAUTION

- **The exhaust gas temperature will rise during regeneration, so beware of burns, fires, etc.**
- **The SCR must never be modified. The machine will not be able to function properly, and it will not satisfy exhaust gas emissions standards.**
- **Do not turn the engine off immediately after regeneration. Put the throttle lever in the idling position, and let the engine idle to gradually cool it for around 5 minutes.**
- **Stopping the engine suddenly without letting it cool may shorten the life span of engine parts.**
- **Continuing to use the machine without carrying out regeneration when the parked manual regeneration lamp / regeneration lamp is flashing may, in the worst case scenario, result in a limit being placed on the engine output. Promptly carry out parked manual regeneration.**
- **Parked manual regeneration can be carried out any time, but limit it to once daily except when the parked manual regeneration lamp / regeneration lamp flashes.**
- **Operating the parking brake switch or accelerator lever during parked manual regeneration will automatically stop regeneration. Restart parked manual regeneration in accordance with the prescribed procedures.**

2 OPERATION

4) Carrying out regeneration on cold days

Be sure to let the engine warm up adequately on cold days before carrying out regeneration.

As a rough guide, let the engine warm up until the thermometer indicates the position shown in the illustration on the right.

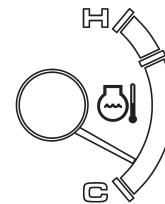

Temperature gauge

5) Disable regeneration

To prevent fires and burns from high temperature exhaust gas during regeneration, disable regeneration by pressing the disable regeneration switch if there is a danger of the gas coming into contact with nearby flammable materials.

When safety has been secured, promptly turn OFF the disable regeneration switch.

Pressing the disable regeneration switch will turn ON the disable regeneration lamp  and stop regeneration.

Pressing the switch again will turn off the lamp , and enable regeneration.

WARNING

When there are flammable materials (paper, dead leaves, etc.) or people nearby, disable regeneration to prevent fires and burns from high temperature exhaust gas.

6) Implement the following procedures when there is an abnormality in the DEF SCR system.

• When the DEF level is low

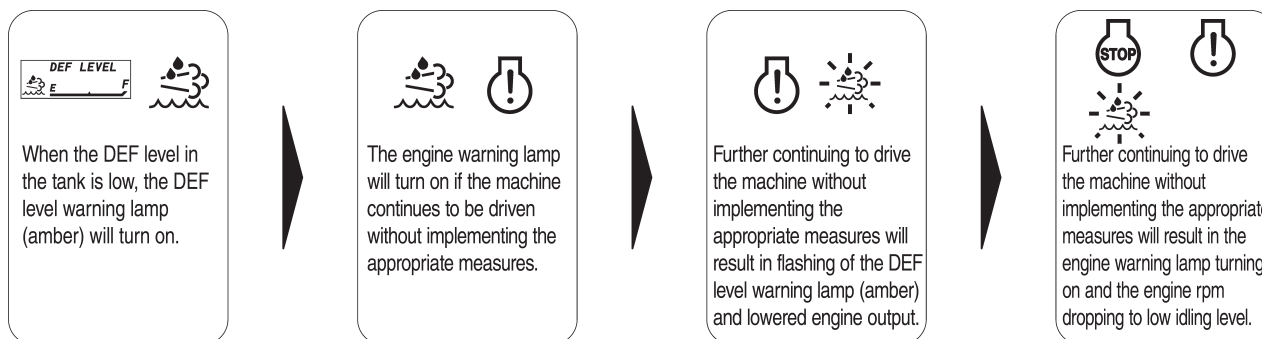

Countermeasure: When the above warning is displayed, fill the tank immediately with DEF designated by our company.

If the warning lamp does not turn off even after filling the tank with DEF, stop the engine, make sure the system busy lamp turns off, then turn the starter switch from the | position to the ○ position twice before restarting the engine.

- When there is an abnormality in the DEF quality

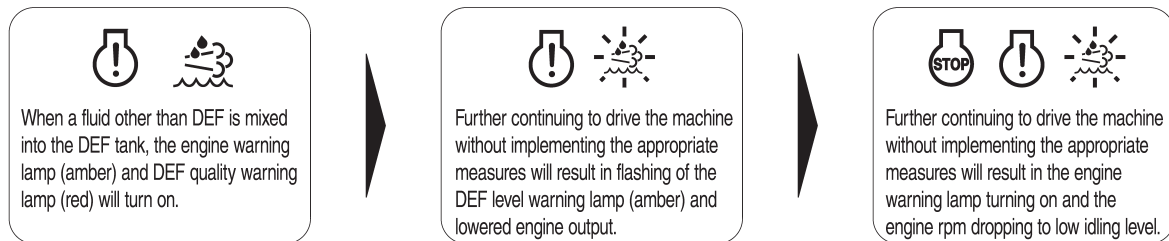

Countermeasure: When the above warning is displayed, completely drain the fluid from the DEF tank, and change it to the DEF designated by our company. If the warning does not turn off even after changing the DEF, stop the engine, turn the starter switch from the I position to the O position twice, then restart the engine.

- Abnormality in the DEF SCR system

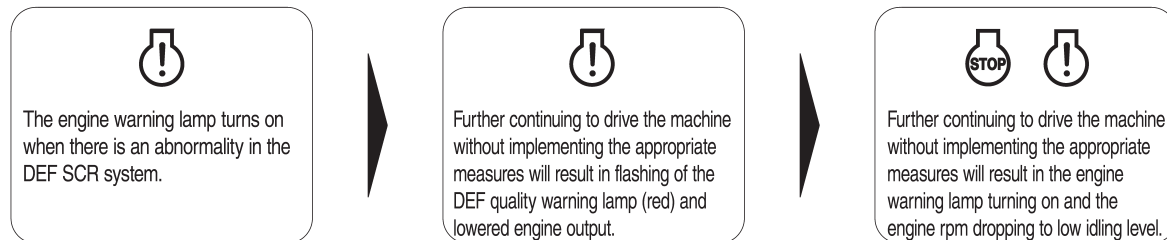

Countermeasure: When the above warning is displayed, contact one of our sales offices or a factory designated by our company for advice.

2 OPERATION

⚠ WARNING

- DEF on the skin may cause inflammation in some people, so contaminated clothes, shoes, etc., should be taken off and washed in cold or warm water. If there are any changes in appearance or pain, promptly seek medical help.
- If the DEF is accidentally swallowed, rinse out your mouth well with water, and promptly seek medical help.
- If the DEF gets in your eyes, rinse it out immediately in clean water for several minutes, then promptly seek medical help.
- Wear protective glasses when there is a danger of the DEF splattering. Wear rubber gloves if work requires you to come into contact with the DEF.
- Do not put anything other than DEF into the DEF tank. Diesel, gasoline, etc., in particular may cause fires. Moreover, putting additives in the tank may lead to generation of toxic gases.
- Opening the DEF tank cap may release toxic ammonia gas. When opening the cap or filling the tank, keep your face away from the filler port.
- If the DEF is spilled, promptly wipe it clean and wash with water. Neglecting to do so may lead to toxic gases or corrosive substances being given off.

⚠ CAUTION

- Put AUS32 or ISO (International Organization for Standardization) ISO22241-1 certified DEF in the DEF tank.
Using anything else may cause breakdowns in the DEF SCR system.
- Never modify the DEF SCR system.
- The machine will not be able to function properly, and it will not satisfy exhaust gas emissions standards. It may also damage the machine.
- The machine will continue running for several minutes after the engine starter switch has been turned off, but this is to pump the DEF left in the pipes, injector, and supply pump back into the DEF tank, and it is not abnormal.
Moreover, do not pull out the battery cord while the system is still running.
- Keep the DEF tank topped up by refilling it at the right time.
- When storing the machine for a month or more, fill up the DEF tank (Except for on cold days).
- If the machine is not used for two month or more after storage, change the DEF pump filter and fill up the DEF tank before starting the engine.
- If a year or more has passed since refilling the DEF tank, contact one of our sales offices or a factory designated by our company to change the DEF pump filter and the DEF before starting the engine. Starting the engine without doing so may cause the SCR system to break down.
- Check the DEF SCR system to make sure there are no abnormalities after starting the engine.
If there is something wrong with the DEF SCR system, stop the engine and restart it.

2.6 Precautions for Work

2.6.1 Compaction operation

■ Understand the intended purposes of the rollers

- This roller is developed and manufactured mainly for compacting soil. Working with vibrations under excessive rolling compactions or using for crushing operations may cause damages to this machine. Do not use for any other purposes than rolling compactions in civil engineering works.

■ Do not operate the vibration on a hard location

- Do not work the vibration on a hard surface such as concrete pavement, as this can cause the machine to jump and give abnormal shock load. Damage to shock isolators will result.

■ Change the direction of travel gently

- When changing the direction of travel during compaction, slowly shift the F-N-R lever.

■ Drive at a speed appropriate for the road surface conditions

- Drive slowly on uneven surfaces.

2.6.2 When going downhill

■ Use the F-N-R lever

- Run slowly going downhill. Do not use excessive speed. Avoid changing speed if possible when going downhill. Start slowly and end slowly on steep downgrades.

■ Use the engine brake

- Go downhill by applying the engine brake along with the F-N-R lever operation.

⚠ WARNING

- When going uphill, run at low speed. Can not attempt to shift speeds during travelling. The machine can slip down the slope.
- When going downhill, adjust the travel speed not to allow the engine speed to exceed 2,500 rpm.

2.6.3 On a slope

■ Working on a sidehill

- Work in an uphill / downhill direction, and avoid working on sidehill with the machine inclining sideways.

2.7 Applicable Jobs

The machines do a variety of jobs as listed below.

1) This machine is mainly used for:

- Static compacting work
- Vibratory compacting work

2) Road rollers do a variety of jobs as listed below.

This machine most effectively handles works or materials marked ☆ .

Work

- Asphalt road paving
- Dust removal treatment for road
- ☆ Road improvement
- ☆ Embankment construction
- ☆ Dam construction
- Construction of forestry and farm roads
- Foundation building
- Construction of sidewalk, shoulder and gutter foundation

Material to be compacted

- Asphalt pavement
- ☆ Crusher run
- ☆ Cement concrete
- ☆ Sands
- ☆ Soils
- ☆ Slag
- ☆ Soft rock

Layers to be compacted

- Surface course, Binder course
- ☆ Base course
- ☆ Subgrade
- ☆ Embankment
- Shoulder
- Sidewalk

2.8 After Operation

Check for the coolant temperature, engine oil pressure and fuel level.

Follow the procedures below to prevent the machine from falling into an unworkable condition the following morning caused by muds and other extraneous matter on the drum, or frozen drums:

- 1) Check to see if the engine coolant temperature is too high and the engine oil pressure is not normal. Also check the fuel level.
- 2) Remove muds and water from the machine. Muds can get into the seals together with water drops on the hydraulic cylinder piston rod. Damaged seals will result.
- 3) Park the machine on a hard and dry surface. If such a place is not available, cover the ground with hard plates.

IMPORTANT

Do not wash clean with high pressure water around the instrument panel or reverse side of the dash board. This can cause instrument failures.

2.9 Loading and Unloading

⚠ WARNING

- **Use sturdy ramps with proper width, length and thickness which allow safe loading and unloading.**
- **If the ramps deflect considerably under load, apply wooden blocks to reinforce them.**
- **Loading should be conducted on a level and hard ground. Leave a sufficient distance between the machine and the shoulder.**
- **To prevent slippage on the ramps, keep the drums free from mud, oils, etc. The ramps must also be free of grease, oil and ice.**
- **Do not steer the machine on the ramps. If the machine is facing in the wrong direction, allow it to dismount from the ramps and correct the direction.**

For loading and unloading, use ramps or a proper loading stand.

2 OPERATION

2.9.1 Use of a truck or trailer equipped with a winch

⚠ WARNING

Placing the unloader valve in UNLOAD position disrupts the power for traction. Do not enter the areas ahead of and behind the machine. It is very dangerous.

- 1) Engage the truck or trailer brake and chock its wheels. Fix the ramps so that the machine and truck or trailer are completely aligned.
 - ☆ The angle between the ramps and ground must be less than 15 degrees.
 - ☆ Leave a proper space between the ramps according to the width of the roller drum.
- 2) Decide the correct direction of run and make the machine run forward to the ramps.
- 3) Draw the wire rope from the truck or trailer winch and put its hook on the hooking point ① or ② (One each on right and left) of the roller.
- 4) Place the unloader valve located at the inside of a frame to the UNLOAD position (refer to “Unloader valve” on page 38).
- 5) With the engine running at idle, perform loading by means of the truck or trailer winch.
- 6) When the loading is completed, set the unloader valve back in the ONLOAD position.
- 7) Locate the machine correctly on the truck or trailer.

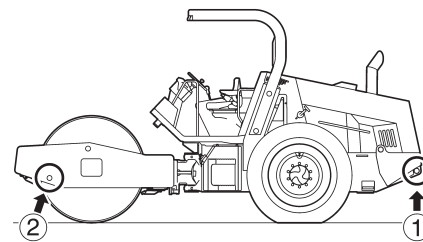
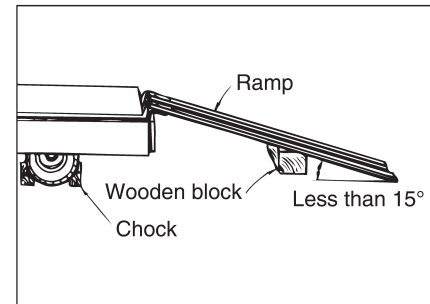

2.9.2 Self-propelling

- 1) Engage the truck or trailer brake and chock its wheels. Fix the ramps so that the machine and truck or trailer are completely aligned.
 - ☆ The angle between the ramps and ground must be less than 15 degrees.
 - ☆ Leave a proper space between the ramps according to the width of the roller drum.

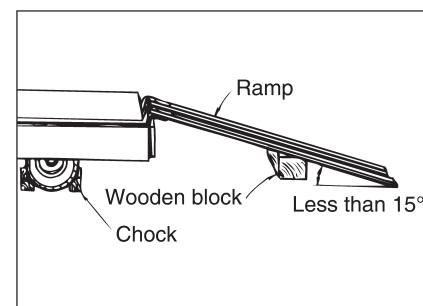

- 2) Decide the correct direction of run and conduct loading or unloading at low speed.

For loading, run forward at low speed.
For unloading, run backward at low speed.

- 3) Locate the machine correctly on the truck or trailer.

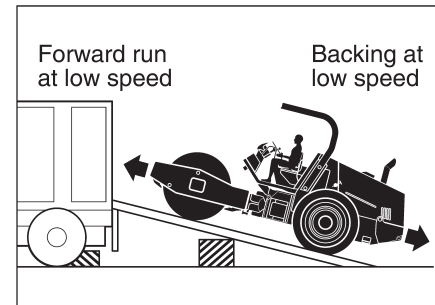

2.10 After Loading the Machine

When the machine has been located properly on the trailer, tie it down as follows:

- 1) Press the parking brake switch button to apply the parking brake. Place chock under the drums to prevent movement.
- 2) Fix the machine with chains tied at the front and rear towing hook holes. Particularly, pay attention to sidewise skidding.

2.11 Transportation

⚠ WARNING

To decide the transporting route, check the width of the road, height and weight (including the roller) of the trailer.

For transportation, obey traffic regulations.

2.12 Operation in Cold Weather

In cold weather, take the following measures to prevent troubles such as starting difficulty and coolant freeze-up.

2.12.1 Fuel oil and grease

Use fuel and oil with low viscosity. Refer to "Rating" on page 113.

2 OPERATION

2.12.2 Coolant

⚠ WARNING

Do not bring an open flame to the antifreeze or do not smoke when handling it. It is flammable.

⚠ CAUTION

Use ethylene glycol-base antifreeze.

For the cooling water, mix the antifreeze in water.
Use softened water as the water to be mixed.
Please refer to the following table for the mixing ratio.

Ambient temperature	Always
Amount of antifreeze	12.5 L (3.3 gal)
Amount of water	12.5 L (3.3 gal)
Ratio	50%

Our machines are filled with a long-life coolant.
The life of the antifreezer is for two years.
Use non-amine type long-life coolant when changing coolant.

⚠ WARNING

- **Do not remove the radiator cap while the coolant is hot.**
 - **Hot water may be spouted out that can cause scald.**
- Relieve pressure by slowly turning the cap after the water temperature is dropped, then remove the cap.**



⚠ CAUTION

Failure to follow this procedure can result in severe engine damage.

- Fill :**
- 1) **Open heater valves that can be found beneath the engine, and turn the heater to “heat” mode (only the appropriate machine).**
 - 2) **Fill coolant at 3 gallons per minute (12 liters per minute) until coolant reaches the bottom of the fill neck. Wait for 1 minute, then top up coolant to the bottom of the fill neck if needed.**
 - 3) **Start engine and run at “mid” speed for 1 minute or until engine warning lamp comes on.**
 - 4) **Turn off engine and top up coolant to bottom of fill neck if needed.**
 - 5) **Replace coolant cap.**

2.12.3 DEF

When the DEF inside the tank freezes, it may expand damaging equipment inside the tank or parts.

Fill the tank with the prescribed amount of DEF while it is cold (less than half if there is a danger of freezing).

The DEF freezes at -11°C .

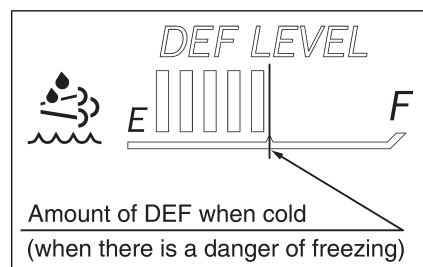
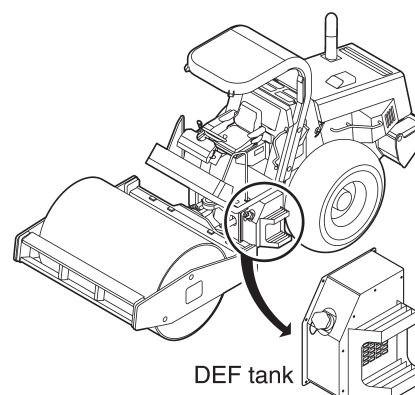

2.12.4 Battery

⚠ WARNING

- The battery contains diluted sulfuric acid, which will dissolve clothes and skin. Should you get battery fluid on your clothes or skin, wash it off immediately with copious quantities of clean water.
- If you get it in your eyes, rinse them straight away with clean water and immediately seek the help of a doctor.
- If you accidentally ingest it, drink copious quantities of water and immediately seek the help of a doctor.
- Always wear safety glasses when handling the battery.
- The battery generates hydrogen gas, so there is a danger of explosions. Avoid recharging the battery, keep cigarettes and flames away, etc., in poorly ventilated places when there is a danger of generating sparks.
- The inspection and handling of batteries should be carried out with the engine turned off and the starter switch in the \bigcirc position.
- Turn the starter switch to the \bigcirc position, then wait at least 30 seconds before removing the battery. An abnormality may arise in the ECM (engine control module).
- Be careful not to accidentally connect the two battery terminals with tools or other metallic objects.
- Tangled terminals may generate sparks due to improper connections, resulting in the danger of explosions. Make sure terminals are connected firmly.
- The battery is for starting the engine and operating electrical equipment on the machine. Do not use it for any other purpose.

2 OPERATION

⚠ CAUTION

The power-supply voltage of this machine is 24 V.

IMPORTANT

When this machine is shipped, maintenance free battery is installed.

When the temperature decreases, the battery capacity will lower, possibly freezing the electrolyte.

The battery should be maintained in a good state at all times, with care taken to keep it warm in preparation for use the next morning.

Hydrometer atop the battery permits confirmation of the condition of the battery.

Green Satisfactory

Black..... Charging is necessary

Semitransparent · Replacement is necessary

Please refer to “3 PERIODIC MAINTENANCE” Battery (refer to page 91) for inspection and maintenance of battery.

2.13 When the Cold Season is Over

When winter is over and the warm season has come, proceed as follows:

- Change oil and fuel with those for use in warm season (refer to page 113).
- Check to make sure there is no damage to parts inside the DEF tank. Carry out repairs if there is any damage.

2.14 For a Long Storage Period

For leaving the machine unused for longer than one month, proceed as follows:

- 1) Store the machine in a closed area after cleaning.
- 2) Conduct oiling, greasing and changing of oil.
- 3) Fill up the DEF tank. However, fill the tank with DEF to less than half full if there is a danger of freezing.
- 4) Grease lubricate the exposed portion of hydraulic cylinder piston rods.
- 5) Cover the battery after disconnecting the negative cable or take off the battery from the machine and store in a safe place.
- 6) If the temperature is expected to go down below 0°C, add antifreeze to the coolant.
- 7) With F-N-R lever placed at neutral position (N) and vibrator switch at O position, have the parking brake engaged.
- 8) Chock the machine.
- 9) Remove the starter key.

2.15 During the Storage Period

⚠ WARNING

If necessary to operate the machine in indoor storage space, ensure good ventilation keeping windows and doors open to prevent gas poisoning.

- During storage, operate the machine at least once a month to prevent the oil films on the lubricated parts from deteriorating and to charge the batteries.
- To prevent the brake linings from sticking to the brake drum, disengage the brake once a month. Exercise care not to allow the machine to move unexpectedly.

⚠ CAUTION

Follow the procedures below if the machine is not used for two months or more after storage.

- **Change the DEF pump filter and fill up the DEF tank before starting the engine.**
- **Check the SCR system to make sure there are no abnormalities after starting the engine.**
- **If there is something wrong with the SCR system, stop the engine and restart it. If there is an abnormality in the SCR system even after restarting the engine, contact one of our sales offices or a factory designated by our company.**
- **If a year or more has passed since refilling the DEF tank, contact one of our sales offices or a factory designated by our company to change the DEF pump filter and the DEF.**
- **Dispose of the drained DEF in accordance with the local environmental laws, rules and regulations.**
Old DEF may give off an ammonium smell. Change the DEF in a well-ventilated place.

2.16 When the Battery has Discharged

⚠ WARNING

- To check and handle the batteries, keep the engine stopped with the starter switch in the \circ position.
- The batteries give off explosive gases. Do not smoke close to the batteries. Keep flames and sparks away from the batteries.
- The electrolyte is very corrosive and will harm your clothing or skin. If the electrolyte has come into contact with your clothing or skin, flush with sufficient amount of water. In case the electrolyte has gotten into your eyes, flush with water and get medical help.
- To disconnect the battery cables, start with the negative terminal (earth). When connecting, start with the positive terminal. Do not allow a metallic item to bridge between the positive terminal and machine body. This can generate sparks, causing an explosion.
- Loose battery terminals can cause sparks. An explosion will result. When connecting the terminals, make certain that they are tight.

Disconnect with negative cable first

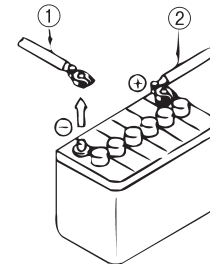

Connect with positive cable first

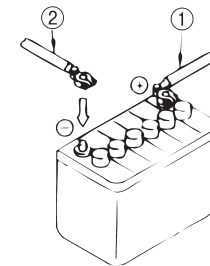

⚠ CAUTION

The power-supply voltage of this machine is 24 V.

2.16.1 Connection and disconnection of booster cables

When jump-starting the engine, connect the booster cables as follows:

■ Connection of booster cables

- 1) Connect one end of the positive booster cable (A) to the positive \oplus terminal of the dead battery on the machine.
- 2) Connect the other end of the positive booster cable to the positive \oplus terminal of the live power supply.
- 3) Connect the negative live power cable (B) to the negative \ominus terminal of the booster supply.
- 4) Connect the other end of the negative booster cable to a good earth ground on the engine block of the machine.

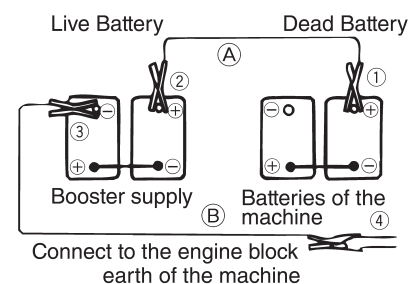

■ Disconnection of booster cables

- 1) Disconnect the negative booster cable (B) from the engine block earth.
- 2) Disconnect the negative booster cable (B) from the booster supply.
- 3) Disconnect the positive booster cable (A) from the booster supply.
- 4) Disconnect the positive booster cable (A) from the machine.

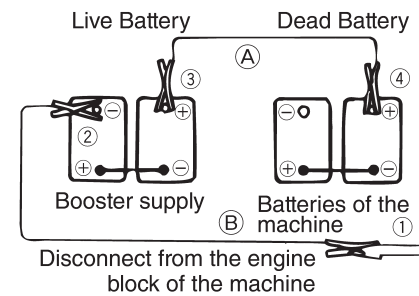

⚠ WARNING

- Do not allow the positive \oplus terminal to make contact with the negative \ominus terminal when connecting the booster cables.
- Wear safety goggles when jump-starting the engine.
- Do not allow the machine to make contact with the booster supply.
- Do not make wrong connections. Connect the negative \ominus cable to the engine block earth far away from the battery, as sparks may occur when connecting.



⚠ CAUTION

- Use booster cables and end clips of proper size suited to the battery capacity.
- Use the batteries of the equal capacity for the machine and booster supply.
- Check booster cables and end clips for signs of damage and corrosion.
- Securely connect the clips.
- The power-supply voltage of this machine is 24 V.

3 PERIODIC MAINTENANCE

3.1 Precautions

Whether or not the inspection service and lubrication are performed at the correct regular intervals exerts significant influence on the occurrence of problems and service life of the machine. In this manual, typical intervals for inspection and service are given. However, flexibility should be exercised as to interval or type of services to enable your machine to always operate in the best condition.

⚠ WARNING

Be sure to take adequate care not to burn yourself when replacing filters, elements, oil, etc.

IMPORTANT

- **After maintenance and inspection record the result of inspection. Remember that replacement of filter elements, replenishment and change of oil and grease, and cleaning the radiator fins are important.**
When draining a hot oil, use care not to get burned.
- **Waste oil, waste coolant, waste DEF, and used filters, elements, etc., should be handled by specialized disposal companies.**

General precautions

- 1) Always use SAKAI genuine parts for replacement.
- 2) Use lubricants recommended by SAKAI. Avoid mixing different brand lubricants.
- 3) For hydraulic oil replenishment, changing, level checking, filter cleaning or replacement, oiling and greasing, use extreme care to prevent dust from entering.
- 4) For checking oil level or changing oil, park the machine on a level and hard surface.
- 5) Change oil while warm.
- 6) For a long-term storage, fill the fuel tank, lubricate necessary points and run the machine for more than 20 minutes once a month. Completely fill the DEF tank except during cold times.
- 7) In freezing weather, add antifreeze to the coolant according to the ambient temperature.
- 8) For the hydraulic pump and motor, have them serviced at authorized service shops.
- 9) Contact one of our sales offices or a factory designated by our company to change DEF hoses and clean the DEF tank.
- 10) Turn the starter switch OFF when performing services such as repairing broken wires, short circuits and tightening loose terminals.

Periodic replacement of essential maintenance parts

In order secure safety for work and travel, conduct inspection and services.

Further, for enhanced safety, following parts and components should be replaced periodically. These parts are prone to material deterioration due to aging or physical change due to friction, it is difficult to determine their useful limit by regular inspection, which makes it necessary to replace with new ones after certain period of service to ensure they function as intended.

If any defects are detected such as crack, deformation or oil leakage, go ahead and replace them even if it is within scheduled replacement time.

System or Mechanism	Part name	Periodical replacement maintenance part	Replacement period	Remarks
1 Brake system	Master cylinder	Seals (rubber parts)	2 years	
	Wheel cylinder	Seals (rubber parts)	2 years	
	Brake piping parts	Brake hose	2 years	
		Air hose	2 years	
Operating parts	Cable	4 years		
2 Steering system	Orbitrol	Seals (rubber parts)	2 years	
	Hydraulic piping parts	Hydraulic hose	2 years	
	Steering cylinder	Seals (rubber parts)	2 years	
	Hydraulic pump	Seals (rubber parts)	4 years	
3 Power transmission system (inclusive of axle)	Axle	Seals (rubber parts)	4 years	
	Travel pump	Seals (rubber parts)	4 years	
	Travel motor	Seals (rubber parts)	4 years	
	Hydraulic piping parts	Hydraulic hose	4 years	
	Isolation rubber	Isolation rubber itself	4 years	
4 Fuel system	Piping parts	Fuel hose	2 years	
5 Engine related	Engine mounting parts	Isolation rubber	4 years	
	Seals (rubber parts)	Packing and others	4 years	
	Drive parts	V-belt	2 years	or 500 hours
	Piping parts	Engine drain hose	4 years	
6 Cooling system	Piping parts	Radiator hose	2 years	
		Radiator breather hose	4 years	
7 Control related parts	Cable parts	Cable	4 years	
8 Intake system	Piping parts	Intake hose	2 years	
		CAC hose	2 years	
9 Hydraulic system	Hydraulic piping parts	Hydraulic hose	4 years	
10 Urea system	Piping parts	Coolant hose for urea system	2 years	
		Urea hose	9000 hours	

3 PERIODIC MAINTENANCE

⚠ CAUTION

- With a new machine, change the engine oil and change the engine oil filter elements after 50 hours of operation for the first time only (refer to page 96).
- When trouble occurs in the location indicated by the indicator lamp on the dashboard display, sensor will work and corresponding lamp comes on. If this occurs, conduct necessary service regardless of the periodic service interval recommendation.
 - 1)The hydraulic filter (line filter) warning lamp ⇨ Replace elements
- Check the electric wiring at a regular interval not exceeding one month, when there is abnormality, replace it.

If there are some trouble on the electric wiring, replace them with new one.

 - 1)Damage to the wire harness and loose clamps
 - 2)Loose sockets
 - 3)Function of electrical systems
- For the parts other than listed above, If there are some trouble on the parts at periodic inspection or daily check. Replace them as soon as possible.

3.1.1 Lifting the machine by hoist

⚠ WARNING

- Get a qualified personnel to lift and lower the machine on a hoist.
- Use sturdy wire ropes.
- Lock articulation by means of lock pin located at the center of machine.

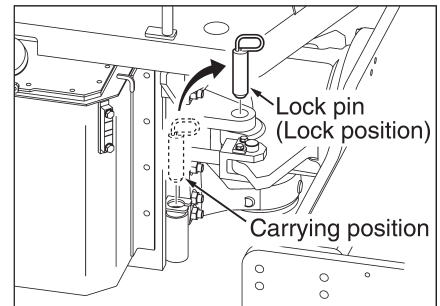

⚠ CAUTION

Remove ROPS before starting lifting work.

- 1) Put wire ropes securely on the hook and lifting points as shown.
- 2) If wire ropes make contact with other parts of the machine, put pieces of cloth or wooden blocks at the contact points. Carefully perform lifting.
- 3) When lifting, keep the machine properly balanced.

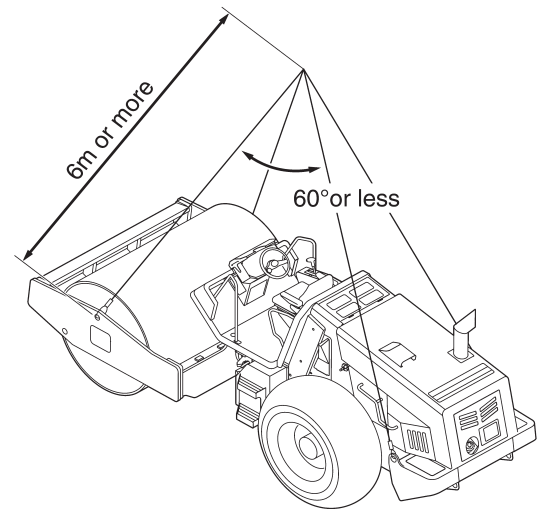

3.2 Walk-around Checking

For efficient operation, daily, before-operation checking is very important. Before starting, perform walk-around checking for loose bolts, nuts and signs of leakage in addition to items as shown below

Hydraulic system & coupling

Oil leakage

Vibrating drum

Bolt looseness
Condition of shockmounts
Unusual wear
Damage

DEF tank

DEF level
DEF leakage

Brake pedal

Function

Hydraulic oil tank

Oil level

Engine fan belt

Looseness

Radiator

Coolant leakage
Coolant level
Fin cleanliness
Clogging

Air cleaner

Clogging

Engine

Oil level
Oil leakage

Pneumatic tires

Unusual wear
Damage
Inflation 137.3 kPa(20 psi)

Fuel tank

Fuel level

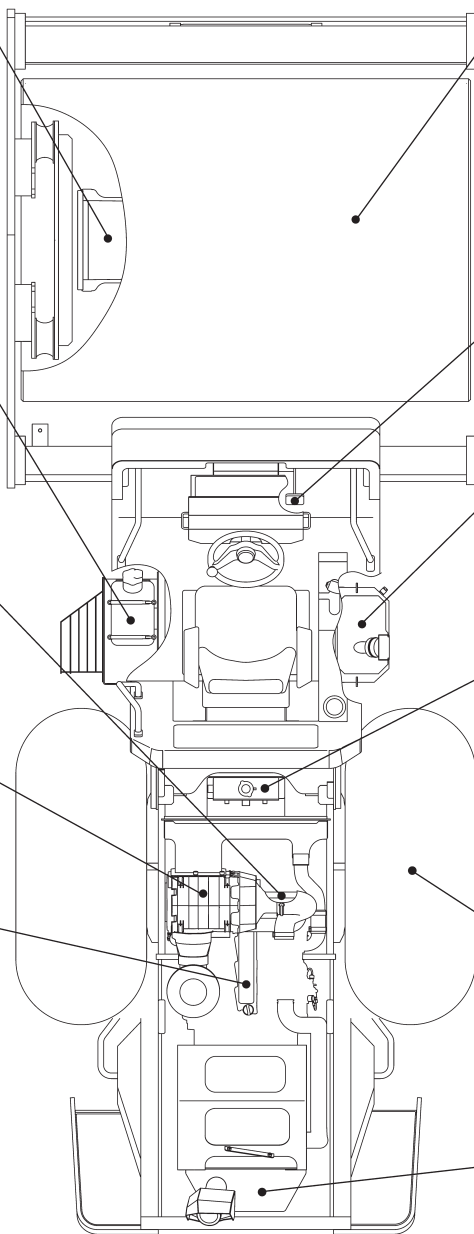

3.2.1 Tire inflation pressure check

Inflation pressure

Check that the inflation pressure of a tire is 137.3 kPa (20 psi) with a pressure gauge when the tire has cooled down. If the pressure reading exceeds the above range, adjust the pressure accordingly.

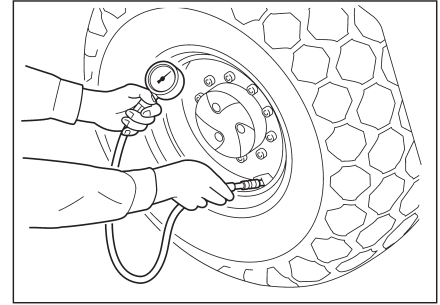

⚠ WARNING

Improper handling of a tire is dangerous and may cause flat tire and a rim to come off.

Do not work on a tire facing the rim, but from behind the tread of the tire while checking the inflation pressure or replenishing air into a tire.

3.2.2 Checking for external injury to a tire

Check any external injury to a tire, its size and its depth (whether it has reached the carcass or not), etc.

- 1) Check for any cuts on the tread.
- 2) Check for any cracks on a rim or deformation of rim flanges.

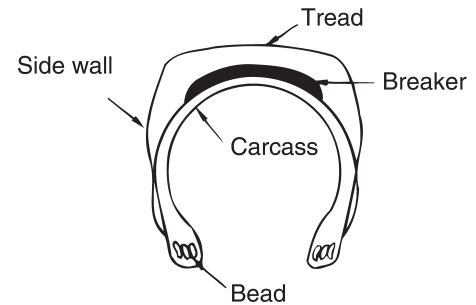

When a tire shows one or more of the following conditions, regard it as defective, and replace the tire with a new one for safety.

- 1) When the bead wire is cut, bent or significantly deformed.
- 2) When the carcass ply is showing due to excessive wear.
- 3) When damaged portion of the carcass exceeds one thirds of the tire width.
- 4) When a tire has ply separation (peeling).
- 5) When radial cracks reach the carcass.
- 6) When the tire is not regarded as durable due to abrasion, deformation, or abnormal flaw growth.

Please consult with dealer for maintenance in the following cases.

- When injury is found on the surface of a tire.
- When the degree of wear on the front, rear, right and left sides of a tire are extremely different.
- When a bent rim is found.

3.3 Periodic Maintenance Points

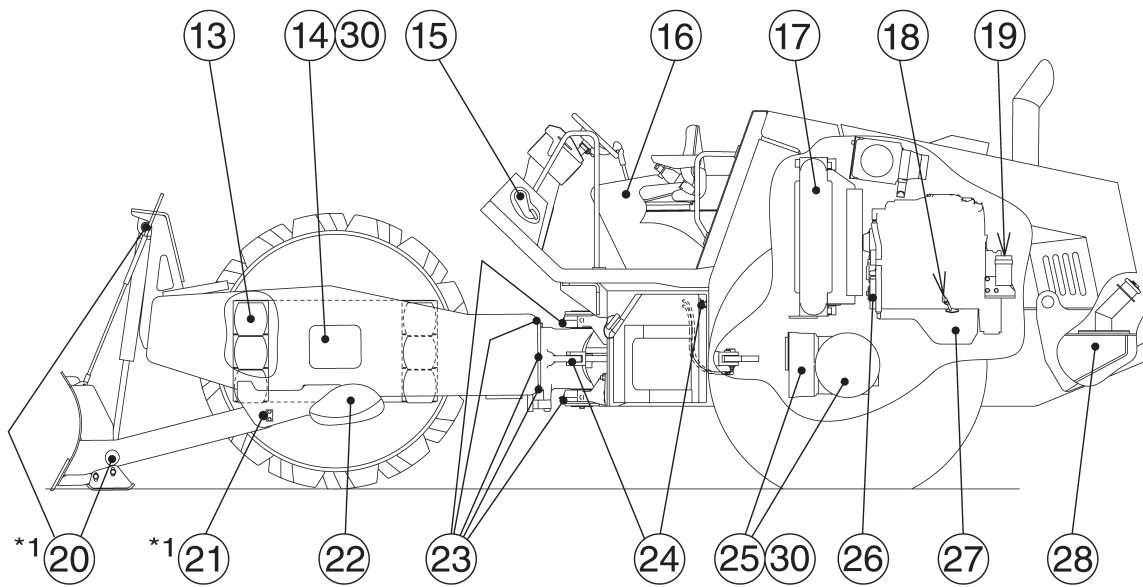
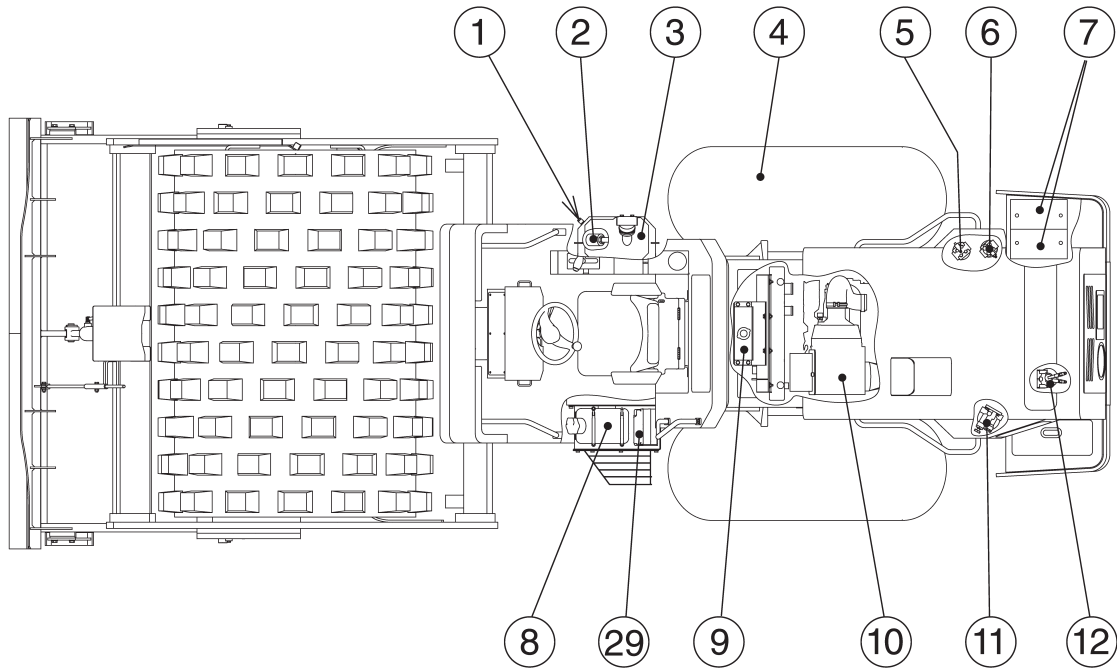

*1 SV544TB, SV544FB only

3 PERIODIC MAINTENANCE

Interval	No.	Item	Service	Lubricant	Q'ty
Every 10 hours or daily	⑨	Auxiliary tank	Check coolant level	Coolant	1
	⑩	Air cleaner	Check indicator		1
	⑪	Fuel pre-filter	Check drain water and dirt		1
	⑱	Engine oil level gauge	Check oil level	Engine oil	1
	⑳	Fan belt	Check tension and unusual wear		1
Every 50 hours	①	Hydraulic oil level gauge	Check oil level	Hydraulic oil	1
	⑦	Batteries	Check looseness of terminal and appearance		2
	⑮	Brake	Check function and adjust Grease 1 place	Grease	1
	*⑳	Blade cylinders	Grease 2 places	Grease	2
	*㉑	Push rod anchor pins	Grease 2 places	Grease	2
Every 250 hours	⑬	Rubber dampers	Check for cracks		10
	㉒	Vibrator	Check oil level	Gear oil	1
	㉓	Center pin and tilt pin bearings	Grease 6 places	Grease	6
	㉔	Steering cylinders	Grease 4 places	Grease	4
	㉕	Transmission, differential case and final drive	Check oil level, add as necessary	Gear oil	1
Every 500 hours	⑤	Hydraulic oil line filter	Change filter element		1
	⑥	Hydraulic oil return filter	Change filter element		1
	⑯	Control link	Check for loose bolts and nuts Grease 1 place	Grease	1
	⑲	Engine oil filter	Change filter element		1
	㉕	Transmission, differential case and final drive	Change gear oil	Gear oil	1
	㉗	Engine oil pan	Change engine oil	Engine oil	1
Every 500 hours or 3 months, or each time after brake pedal is used	⑳	Parking brake	Check function		2
Every 1000 hours	②	Hydraulic oil suction filter	Clean filter element		1
	③	Hydraulic oil tank	Change hydraulic oil	Hydraulic oil	1
	⑪	Fuel pre-filter	Change filter element		1
	⑫	Fuel filter	Change filter element		1
	⑭	Gear case: Wheel motor	Change gear oil	Gear oil	1
	㉒	Vibrator	Change gear oil	Gear oil	1
Every 4000 hours	㉙	DEF pump filter	Change filter element		1
As required	④	Tires	Check inflation		2
	⑧	DEF tank	Check DEF level, add as necessary	DEF	1
	⑩	Air cleaner	Change element		1
	⑰	Radiator	Clean fin		1
	㉘	Fuel tank	Drain water and dirt		1

* SV544TB, SV544FB only

3.4 Maintenance Procedure

➔ For servicing the engine, see the separate engine manual.

(1) Every 10 hours or daily

⑨ Auxiliary tank

Check to see coolant level in the sight glass, if coolant can not be seen, replenish with the auxiliary tank cap removed. Use soft water only.

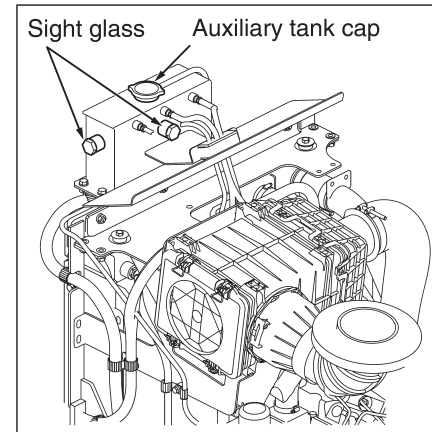

⚠ WARNING

- Do not remove the radiator cap and auxiliary tank cap while the coolant is hot.
- Hot water may be spouted out that can cause scald.



⚠ CAUTION

Failure to follow this procedure can result in severe engine damage.

- Fill :
- 1) Open heater valves that can be found beneath the engine, and turn the heater to “heat” mode (only the appropriate machine).
 - 2) Fill coolant at 3 gallons per minute (12 liters per minute) until coolant reaches the bottom of the fill neck. Wait for 1 minute, then top up coolant to the bottom of the fill neck if needed.
 - 3) Start engine and run at “ECO” speed for 1 minute or until engine warning lamp comes on.
 - 4) Turn off engine and top up coolant to bottom of fill neck if needed.
 - 5) Replace the cap.

NOTE: Replace long-life coolant every two years. Replace the other types every year.

⑩ Air cleaner

When the red float of the dust indicator reaches the service level (a mark on the indicator), change the filter element (refer to page 104).

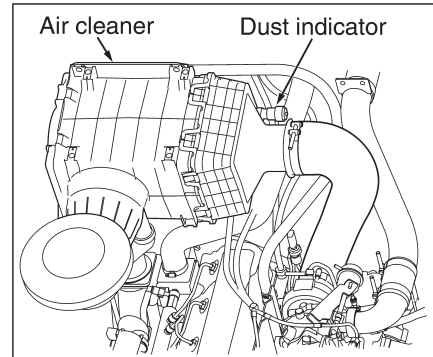

⑪ Fuel pre-filter

Check the filter for water at regular intervals and drain as necessary.

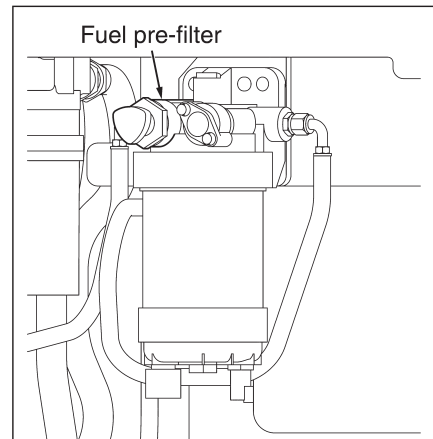

⑱ Engine oil level gauge

➔ See the separate engine manual.

Check the amount of engine oil after the engine is completely stopped. Pull out the oil level gauge and wipe off oils by waste clothes. Re-insert the oil level gauge into the full length of the oil dip pipe and pull it out. Check that the oil level is between “FULL” and “ADD”. In case of shortage, feed oils through the engine oil fill port.

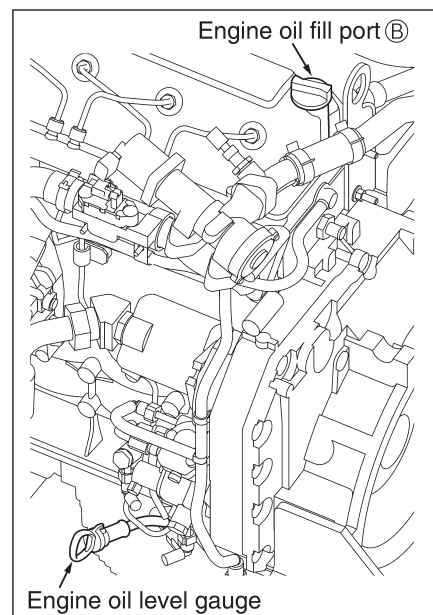

⚠ WARNING

It may cause scald immediately after that the engine is stopped because the temperature of the parts and the oils may be raised. Please start checking it by waiting until the temperature is dropped.

3 PERIODIC MAINTENANCE

⚠ CAUTION

Be sure to use engine oil recommended by SAKAI (refer to page 113).

NOTE: When checking the amount of oils after running the engine, please check at least 15 minutes after the engine is stopped. If the machine is inclined, please move it to the flat ground before start checking it.

②⑥ Fan belt

Check the fan belt for wear and damage. Replace as necessary.

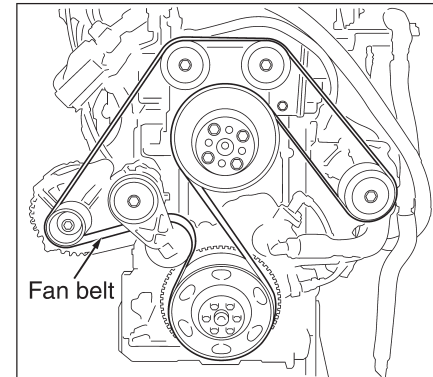

⚠ WARNING

Make certain that the engine is completely stopped to avoid any risks when checking looseness, tensions and damages for the fan belts. Also make certain that the key is removed from the starter switch.

IMPORTANT

Please see the separate engine manual for engine for more details on fan belts.

(2) Every 50 hours

① Hydraulic oil level gauge

Check the oil level with the sight glass on the side of tank. The level is proper if it is between H and L marks. If necessary, add the hydraulic fluid from the fill port.

⚠ CAUTION

Be sure to use hydraulic oil recommended by SAKAI (refer to page 113).

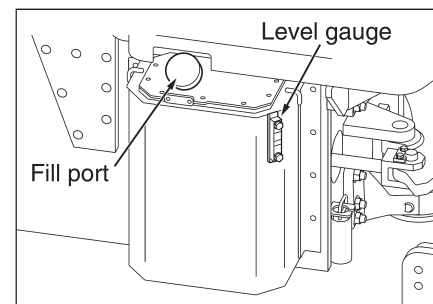

⑦ Batteries

Maintenance-free batteries are installed at the time of delivery.

Inspection and maintenance methods for installed batteries.

- 1) Check the color of the hydrometer attached to the battery top to charge or replace the battery.
 - Green ... Satisfactory
 - Black ... Charging is necessary
 - Semitransparent ... Replacement is necessary
- 2) Retighten any loose terminal. Apply grease or vaseline to the terminals to retard rusting.
- 3) Be sure to tighten the battery holder if it is loose.

Inspection and maintenance methods for non-maintenance-free batteries.

- 1) With the caps removed, check to see if the electrolyte level is above the plates.
- 2) Add distilled water or battery fluid commercially available if the level is too low.
- 3) Retighten any loose terminal. Apply grease or vaseline to the terminals to retard rusting.
- 4) Be sure to tighten the battery holder if it is loose.

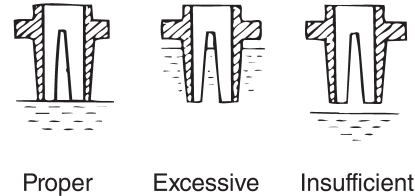

⚠ WARNING

- **The battery contains diluted sulfuric acid, which will dissolve clothes and skin. Should you get battery fluid on your clothes or skin, wash it off immediately with copious quantities of clean water.**
- **If you get it in your eyes, rinse them straight away with clean water and immediately seek the help of a doctor.**
- **If you accidentally ingest it, drink copious quantities of water and immediately seek the help of a doctor.**
- **Always wear safety glasses when handling the battery.**
- **The battery generates hydrogen gas, so there is a danger of explosions. Avoid recharging the battery, keep cigarettes and flames away, etc., in poorly ventilated places when there is a danger of generating sparks.**
- **The inspection and handling of batteries should be carried out with the engine turned off and the starter switch in the “OFF” position.**
- **Turn the starter switch to the “OFF” position, then wait at least 30 seconds before removing the battery. An abnormality may arise in the ECM (engine control module).**
- **Be careful not to accidentally connect the two battery terminals with tools or other metallic objects.**
- **Tangled terminals may generate sparks due to improper connections, resulting in the danger of explosions. Make sure terminals are connected firmly.**
- **The battery is for starting the engine and operating electrical equipment on the machine. Do not use it for any other purpose.**

3 PERIODIC MAINTENANCE

⚠ CAUTION

- Use only batteries recommended by SAKAI (refer to page 115).
- The power-supply voltage of this machine is 24 V.

⑮ Brake

When the engine is completely stopped, step on the brake pedal by two or three times. After this, while forcefully keep stepping on the brake pedal for more than five seconds, check the gap between the brake pedal and the floor panel by rulers. It is appropriate if the gap between the brake pedal and floor panel is 15 mm ±5 mm.

Also check that each bolt is not loose, the motion of the brake pedal is smooth, and the brake pedal is properly resilient when stepping it on.

Apply grease to the brake pedal shaft.

⚠ CAUTION

Be sure to use grease recommended by SAKAI (refer to page 113).

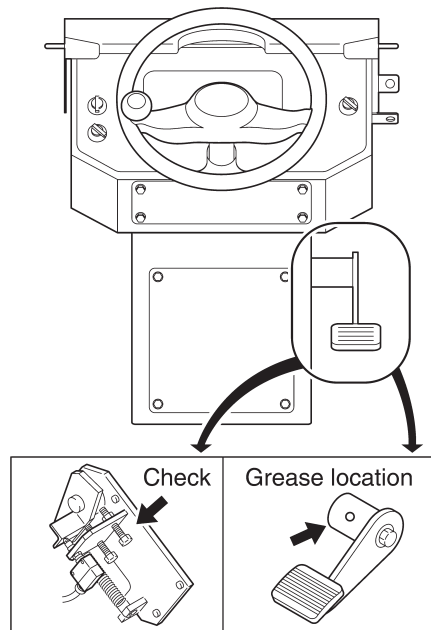
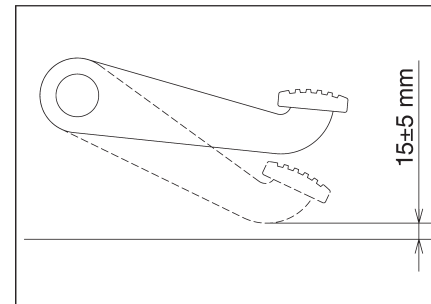

⑳ Blade cylinders (For model SV544TB, SV544FB)

㉑ Push rod anchor pins (For model SV544TB, SV544FB)

Apply grease at 4 locations.

⚠ CAUTION

Be sure to use grease recommended by SAKAI (refer to page 113).

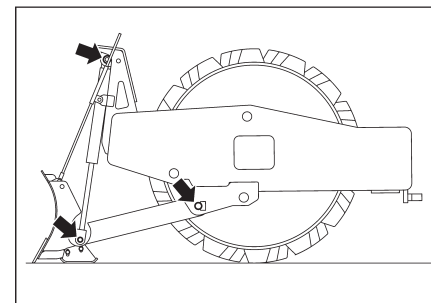

(3) Every 250 hours

⑬ Rubber dampers

Check the rubber blocks for cracks, and their mounting bolts for looseness.

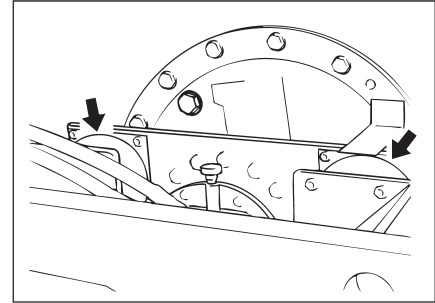

⑭ Vibrator

Check for the oil level and leakage.

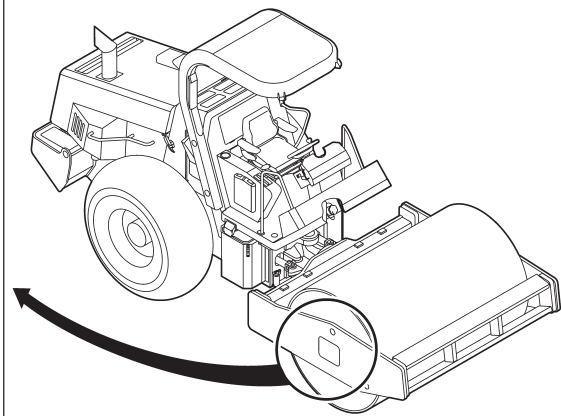
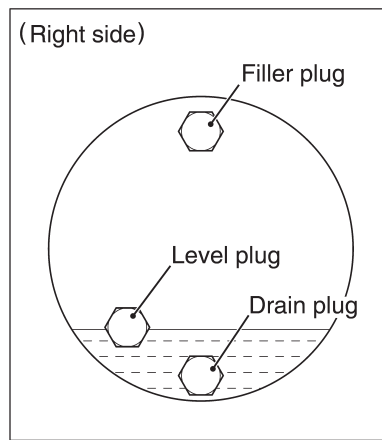

⚠ CAUTION

Be sure to use gear oil recommended by SAKAI (refer to page 113).

⑮ Center pin and tilt pin bearings

Apply grease at 6 locations.

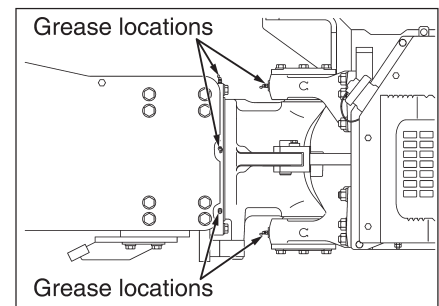

⚠ CAUTION

Be sure to use grease recommended by SAKAI (refer to page 113).

3 PERIODIC MAINTENANCE

24 Steering cylinders

Apply grease at 4 locations.
The steering cylinder is provided on both sides of the machine.

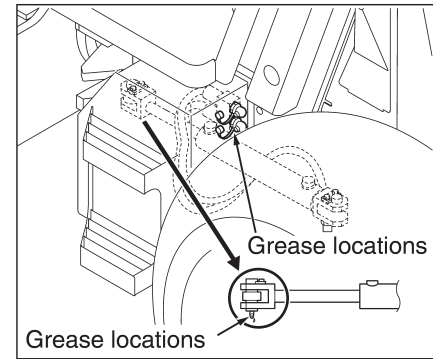

⚠ CAUTION

Be sure to use grease recommended by SAKAI (refer to page 113).

25 Transmission, differential case and final drive

Check for oil level, and add oil through the fill port as necessary.

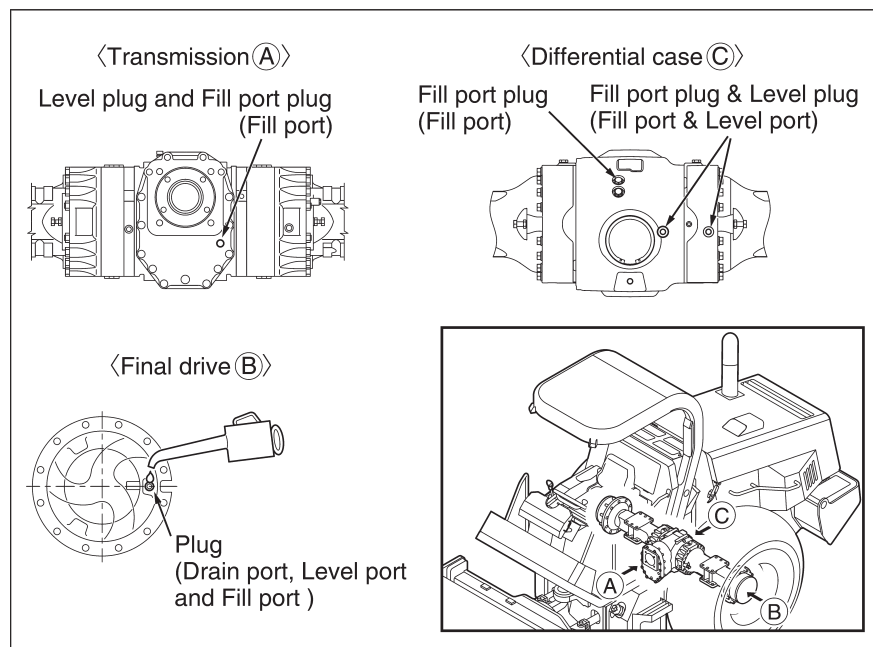

⚠ CAUTION

Be sure to use grease recommended by SAKAI (refer to page 113).

(4) Every 500 hours

⑤ Hydraulic oil line filter

⑥ Hydraulic oil return filter

Change the filter elements.

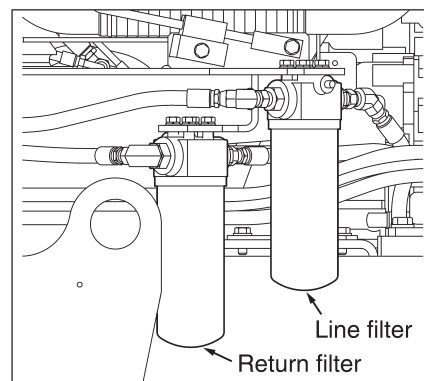

⑩ Control link

- 1) Check the nuts for looseness.
- 2) Apply grease to F-N-R lever shaft.

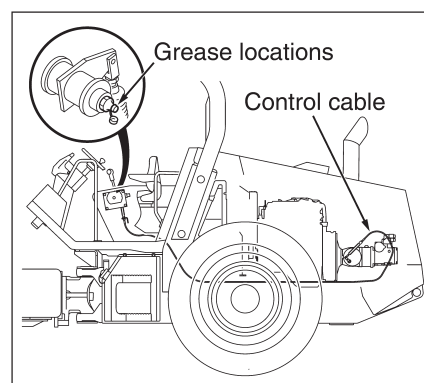

CAUTION

Be sure to use grease recommended by SAKAI (refer to page 113).

3 PERIODIC MAINTENANCE

① Engine oil filter

② Engine oil pan

➔ See the separate engine manual.

- 1) After completion of operation and while the oil is warm, drain the oil with the drain plug ① removed.

⚠ WARNING

When draining a hot oil, use care not to get burned.

- 2) Put the shield tape on it, refit the drain plug ① and fill the crankcase with the engine oil from the fill port ② .

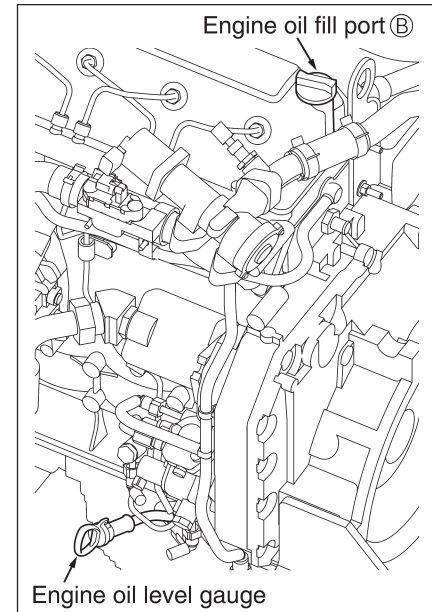
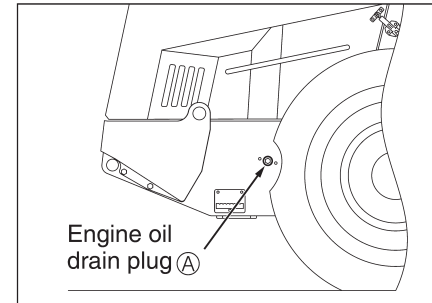

- 3) Change the oil filter element ③ .

NOTE: For a new machine, change oil at 50 operating hours for the initial time only.

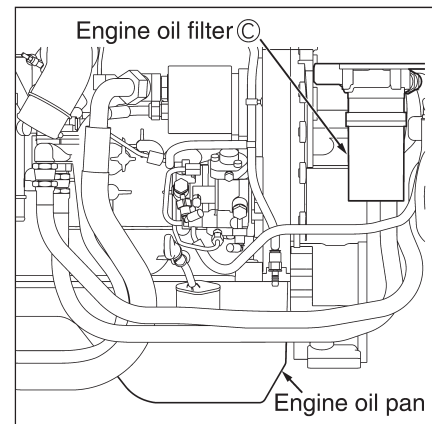

⚠ CAUTION

Be sure to use engine oil recommended by SAKAI (refer to page 113).

25 **Transmission**

- 1) Drain the gear reducer oil by removing the drain plug.
- 2) Refit the drain plug.
- 3) Take off the level plug and fill port plug.
- 4) Fill oil through the fill port until oil starts overflowing from the level port.
- 5) Refit the level plug and fill port plug.

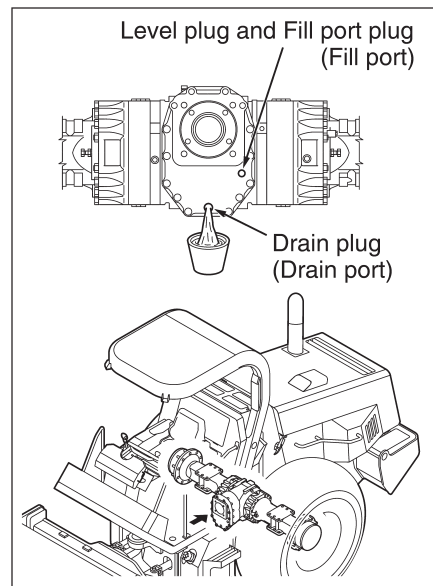

CAUTION

Be sure to use gear oil recommended by SAKAI (refer to page 113).

25 **Final drive**

- 1) Rotate the wheel till the drain port is located at the lowest position. Remove plug to drain oil.
- 2) At the final drive, adjust the position of plug until it is parallel to the ground.
- 3) Fill oil through the fill port till oil overflows from the level port.
- 4) When the final drive case is filled to the specified level, refit the removed plugs.

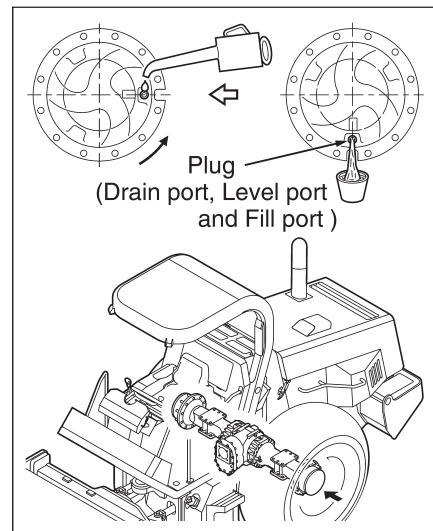

CAUTION

Be sure to use gear oil recommended by SAKAI (refer to page 113).

3 PERIODIC MAINTENANCE

②5 Differential case

- 1) Drain oil by removing the drain plug, fill port plug and level plug.
- 2) Refit the drain plug.
- 3) Fill oil through the fill port till it overflows from the level port.
- 4) Refit the removed plugs.

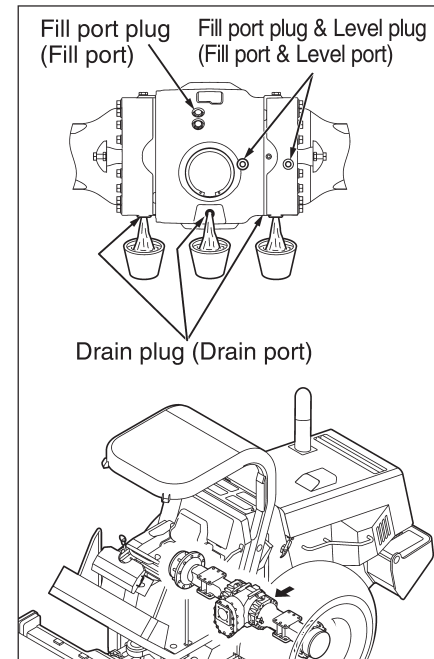

⚠ CAUTION

Be sure to use gear oil recommended by SAKAI (refer to page 113).

(5) Every 500 hours or 3 months, or each time after brake pedal is used**30 Parking brake****⚠ WARNING**

- Ensure safety by checking to make sure there is no one and no obstacles near the machine.
 - Keep your hands on the F-N-R lever and steering wheel during inspections.
- The machine may move in unexpected ways during inspections, leading to accidents.

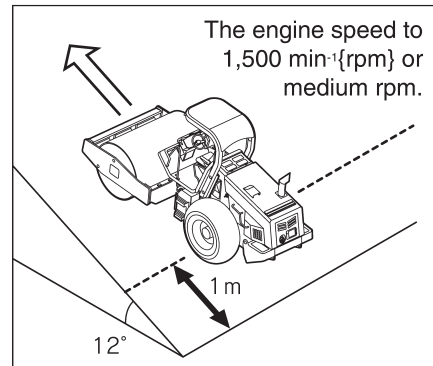

- 1) Adjust the engine speed to 1,500 min⁻¹ {rpm} or medium rpm.
- 2) Be sure to move the machine onto asphalt pavement or an other hard surface with an upward inclination of 12° (20%) with the engine left on.
- 3) Press the Parking brake switch (P) to engage the parking brake. Check that the OK monitor lamp (P) has turned on.

If the lamp (P) does not turn on, contact one of our sales offices or a factory designated by our company for advice.

- 4) Remain seated on the machine to make sure it remains completely still for 1 minute. If it moves, move it immediately to flat ground, stop using it, contact one of our sales offices or a factory designated by our company, and have it repaired.

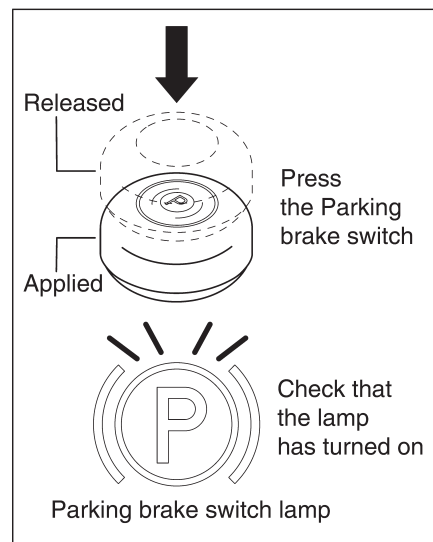
**⚠ WARNING**

- This inspection must be carried out after each use of the brake pedal.
- If the inspection is not carried out, the parking brake may malfunction when you try to use it next time causing a serious accident.
- Making alterations to the machine.
- Please do not make alterations to the machine without permission for safety reasons. We shall not be held responsible for injuries, death or breakdowns caused by alterations.

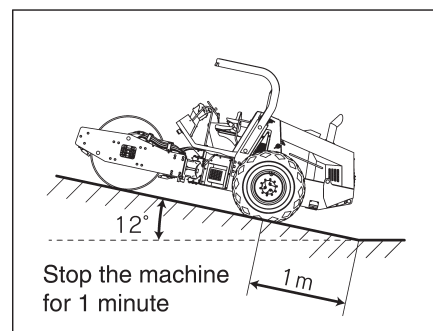

3 PERIODIC MAINTENANCE

(6) Every 1,000 hours

② Hydraulic oil suction filter

Take off the hydraulic tank cover. Take out and clean the strainer, change the strainer if necessary.

③ Hydraulic oil tank

- 1) Remove the drain plug, and drain oil while it is warm.
- 2) Clean inside of the tank, and fill fresh oil to the specified level.
- 3) Start and run the engine at idling for 2 to 5 minutes. When the hydraulic oil has become free from air bubbles, stop the engine and recheck the oil level.

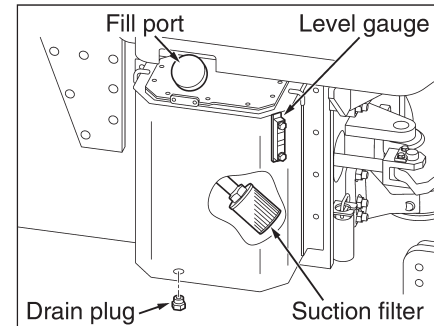

⚠ WARNING

When draining a hot oil, use care not to get burned.

⚠ CAUTION

Be sure to use hydraulic oil recommended by SAKAI (refer to page 113).

⑪ Fuel pre-filter

Change the filter elements.

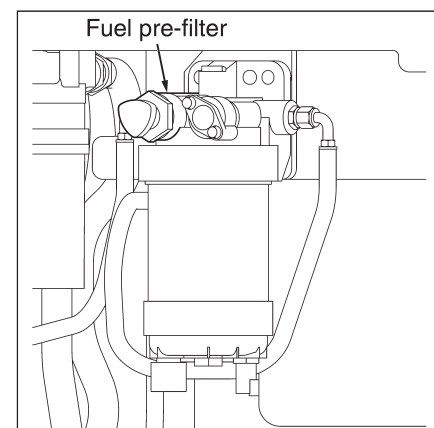

⑫ Fuel filter

➔ See the separate engine manual.
Change the filter cartridge.

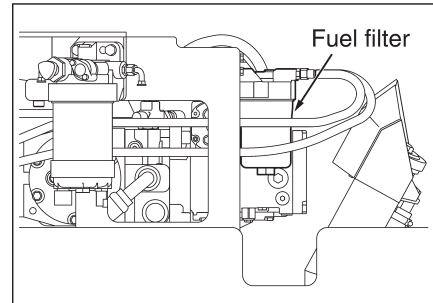

⑭ Gear case : Wheel moter

- 1) Position the drum so that the drain / level port comes to the bottom while the oil inside the gear case is still hot.
- 2) Remove the filler plug and drain / level plug to drain the oil inside the gear case.
- 3) After draining the oil, rotate the drum slowly so that the filler port faces upward.
When doing so, check that the drain / level port is at a position parallel to the ground.
- 4) Supply oil through the filler port (capacity of around 2.9 L) until it overflows from the drain / level port.
- 5) Refit the filler plug and drain / level plug after cleaning them.

When draining

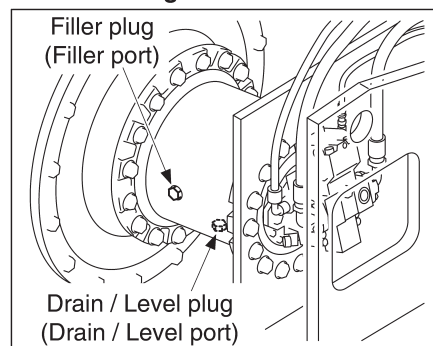

When filling

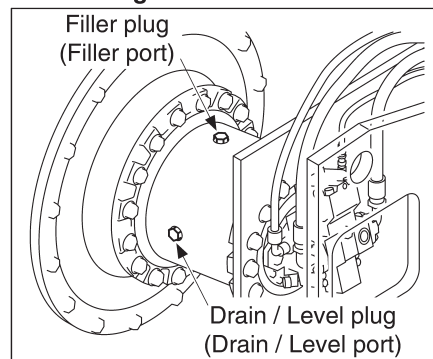

⚠ WARNING

Take care not to burn yourself on the hot oil when draining it.

⚠ CAUTION

Be sure to use gear oil recommended by SAKAI (refer to page 113).

3 PERIODIC MAINTENANCE

22 Vibrator

- 1) Rotate the drum till the drain plug comes to bottom.
- 2) Remove drain plug, level gauge plug and filler plug.
- 3) Drain oil from vibrator.
- 4) Clean the vibrator before reinstalling it.
- 5) Feed oil at filler port until oil flows out of level gauge hole.
- 6) Reinstall the level gauge plug as well as filler plug after cleaning them.

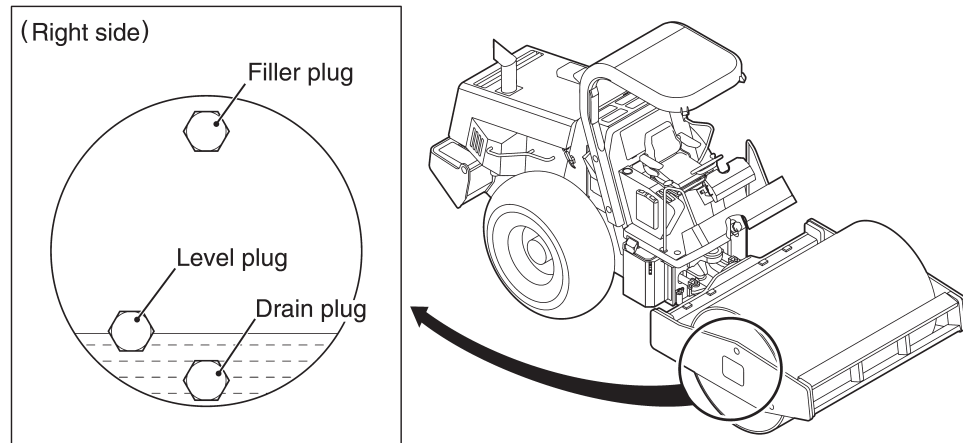

⚠ WARNING

When draining a hot oil, use care not to get burned.

⚠ CAUTION

- The oil capacity of the vibrator is 34 liters. Do not fill more than 34 liters.
- Be sure to use gear oil recommended by SAKAI (refer to page 113).

(7) Every 4000 hours

29 DEF pump filter

- ➔ Refer to 3.5.1 Changing the DEF pump filter (refer to page 110).
Change the DEF pump filter element.

(8) As required**④ Tires**

- 1) Check if there are wears and flaws.
Please check if there are any cracks and damages such as wears on one side, partial wears, step-shaped wears, nails and stones stuck or cut into the tires on the contacting surfaces with the grounds, both side surfaces and all around of the tires. If you find any abnormal conditions, replace tires.
- 2) Check air pressures. Check air pressures with tire gauges when tires are cool enough, and make certain that they are at 137.3 kPa {20 psi}. Adjust air pressures of the tires if they are NOT appropriate.
- 3) Check whether or not the wheel nuts are loose. Check if the wheel hub nuts are loose or fallen off or if wheel hub bolts are broken. Also check if there are any rust fluids and / or whether or NOT the lengths of all the wheel hub bolts projected out of the wheel hub nuts are the same.

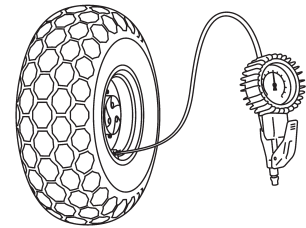
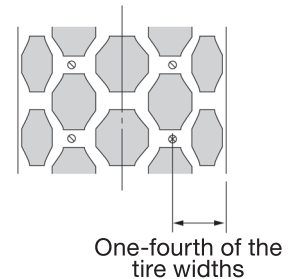
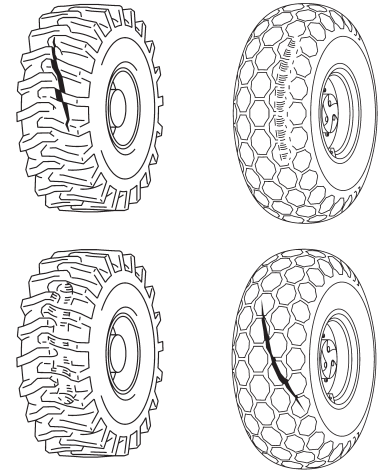

Check the wheel hub nut for looseness. If it is loose, tighten it. Be sure to torque it to the specified value.
Tightening torque: **630 N·m**

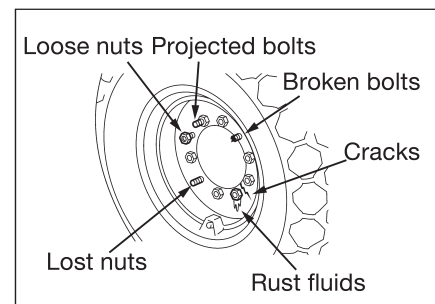
**⚠ CAUTION**

- Turn the wheel hub nut in the tightening direction during inspection.
- Excessive tightening of the wheel hub nut will lead to breakage of bolts or cracks in the disc wheel. Be sure to observe the specified torque.

NOTE: Tighten the wheel hub nut 50 hours after purchase of a new machine or replacement of tires.

Drum

The drum may be worn deeply and broken depending on the operation method and the condition of the site. Check the drum occasionally in the same way as tires.

3 PERIODIC MAINTENANCE

⑧ DEF tank

Check the DEF level.
If it is inadequate, remove the filler cap and fill the tank through the filler port.

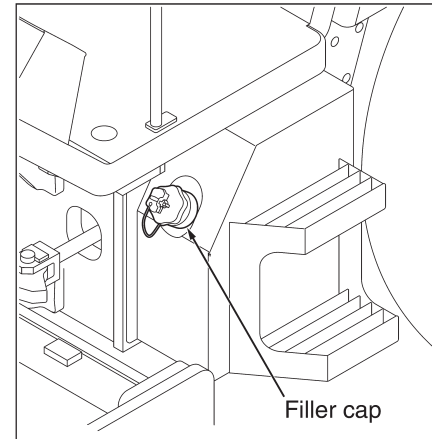

⚠ CAUTION

Be sure to use the DEF recommended by SAKAI (refer to page 113).

⑩ Air cleaner

When the red float of the dust indicator reaches the service level (a mark on the indicator), change the element as described below.

- 1) Release the service door clips to remove the primary element from the main filter housing.
- 2) Primary Element:
Grasp the handle in the center of the element and pull the filter element outward.
Clean the inside of the housing with a damp rag to remove all loose dirt and dust.

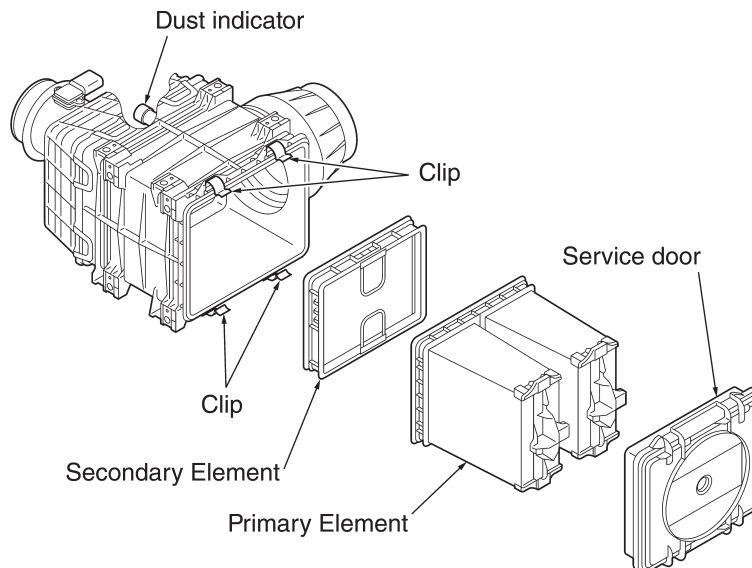

3) Secondary Element

⚠ WARNING

- **Stop the engine before inspection, cleaning, or maintenance, otherwise dust will enter the engine, causing the breakdown of the engine.**
- **Wear protective goggles, a dust respirator, and other protective gear before cleaning the air cleaner and outer element in order to prevent dust from entering your eyes or nose.**
- **Be sure to use our genuine element.**

⚠ CAUTION

- **Take caution when removing the secondary element. Any loose debris can fall into the air intake plumbing leading directly to the engine. Clean the area around the secondary filter element and replace the secondary promptly to avoid engine contamination ingestion.**
- **Do not attempt to clean the filter element. Cleaning filter elements by impact or compressed air voids the warranty and can degrade or damage the filter media leading to malfunction.**

NOTE: The secondary element should be changed every third time that the primary element is changed, if the primary element has been breached then an inspection of the secondary filter must be performed and changed if necessary.
The secondary element is removed by pulling on the plastic ring tabs on the inside face of the filter element.

4) Attach the element and service door it with a clips.

3 PERIODIC MAINTENANCE

17 Radiator

If there is grime or dirt on cover 1, clean it as required.
If cover 1 is clogged up, it may restrict the flow of air leading to overheating.

This cover 1 can be taken off by removing the single bolt at the top.

Moreover, the radiator fins should be inspected at times to make sure there is no grime or dust on them.

Grime or dust on the fins may lead to overheating.

If there is grime or dust on the fins, clean them with an air blower or water.

When cleaning the fins, remove four bolts to take off cover 2. Be sure to put the cover back in its original position after cleaning the fins.

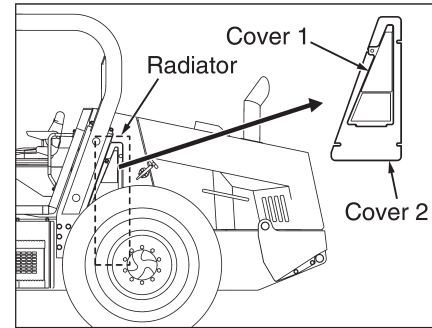

⚠ WARNING

Use the safety glasses or goggles during the use of compressed air.

IMPORTANT

If the discharge rate of compressed air or tap water is too high, it can damage the radiator or the fins of the oil cooler. Keep a distance of 500 mm or more between the nozzle and the core surface.

In case dirt or dust is attached, clean the radiator, the oil cooler and the core with compressed air or tap water.

It is to prevent performance decline of the cooling system.

IMPORTANT

Do not use any driver or steel spatula (or paddle). If it rubs the fins, it can damage the tubing.

28 Fuel tank

- 1) With the drain plug removed, remove the water and sediment from the bottom of the tank.
- 2) If sedimentation is substantial, remove the drain plug and clean the interior of the tank.
- 3) When the necessary work and refueling are complete, tighten the filler cap positively.

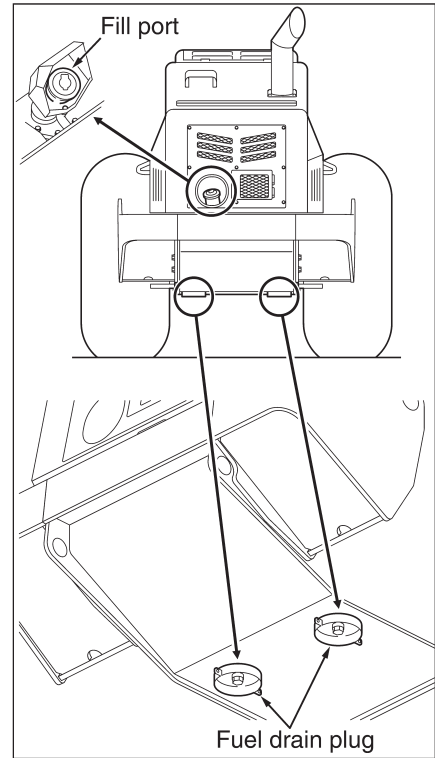

⚠ WARNING

- The fuel will catch fire if open flames or ignition sources are used close to it.
- Do not smoke or use a match or cigarette lighter close to it.



NOTE: When removing the water and sediment from the tank filled with the fuel, the fuel will gush out if the drain plug is screwed out completely.

3 PERIODIC MAINTENANCE

3.5 Consumable Parts

Replace consumable parts such as filter elements and air cleaner elements during periodical maintenance or before reaching the wear limit. Proper replacement of consumable parts will improve the overall life of the machine, resulting in cost-effective operations.

Use genuine SAKAI parts as replacement parts.

The part numbers are subject to change due to the improvements to the parts. When ordering parts, make sure to obtain the latest part numbers by checking with our distributorship or one of our certified service shops of the version, model name and model number of the machine in use.

Consumable Part	Part No.	Interval		Remark
		Annual replacement (year)	Replacement per operation (hours)	
Engine oil filter element	4033-53008-0	0.5	500	
Return filter assembly	4218-71000-1		As required	
Return filter element (hydraulic oil)	4211-41004-1		500	
Line filter assembly	4218-71000-1		As required	
Line filter element (hydraulic oil)	4211-41004-1		500	
Fuel pre-filter assembly	4033-53011-0		As required	
Fuel pre-filter element	4033-53012-0	1.0	1000	
Fuel filter assembly	4033-71007-0		As required	
Fuel filter element	4033-71008-0	1.0	1000	
Suction filter element (hydraulic oil)	4207-79000-0		1000	
DEF pump filter element	4033-79001-0		4000	
DEF tank filter	4033-78002-0		As required	
Air cleaner assembly	4425-19000-0		As required	
Primary element	4423-44001-0		As required	
Secondary element	4424-64001-0		As required	They should be replaced with new ones once in every three times of Primary elements' replacement.
Gas damper	4425-22000-1	2		

3 PERIODIC MAINTENANCE

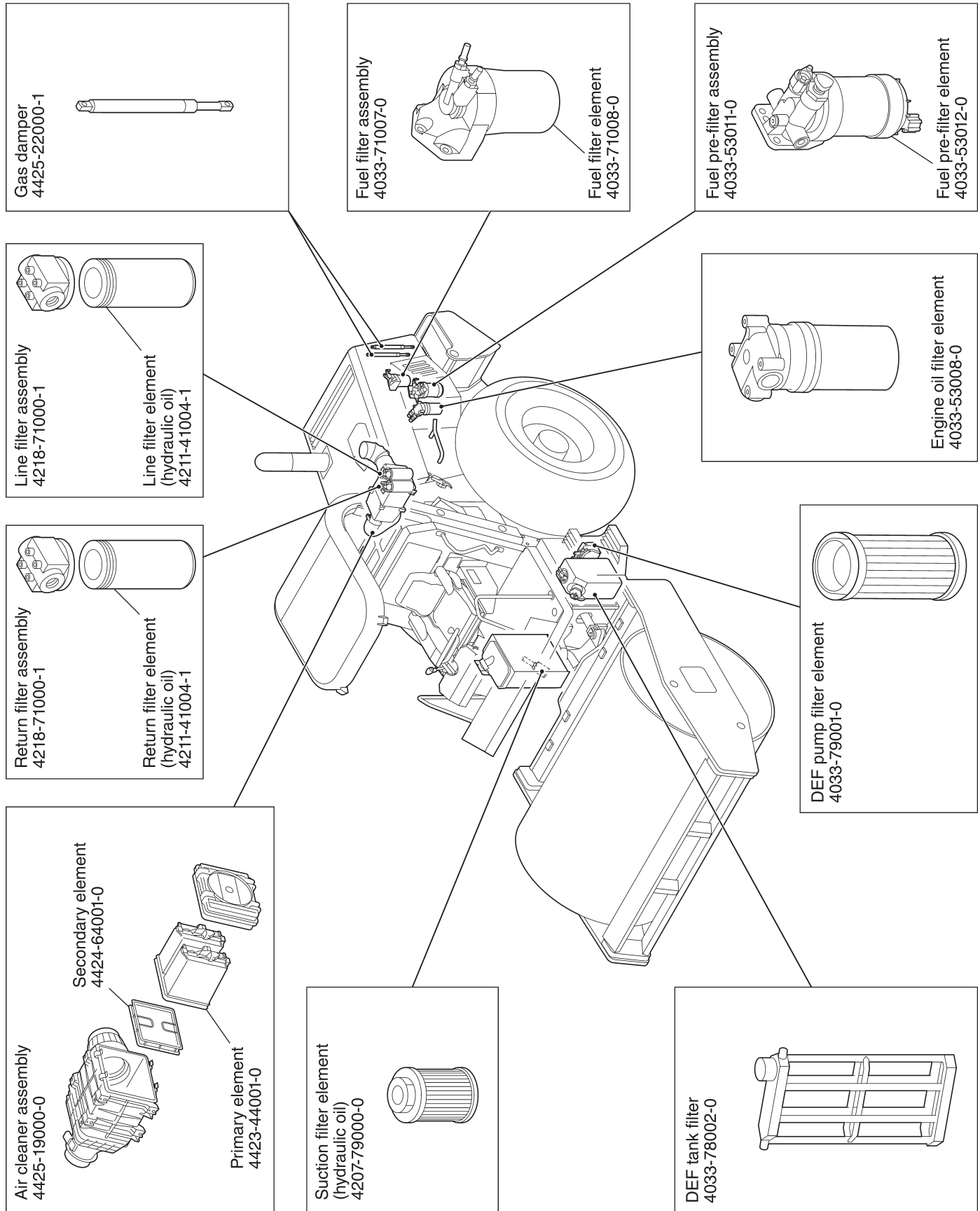

3 PERIODIC MAINTENANCE

3.5.1 Changing the DEF pump filter

⚠ WARNING

The filter cannot be changed immediately after turning off the engine, because the outside will be hot. Change it after everything has cooled down.

IMPORTANT

- Use genuine SAKAI products for replacement parts.
- Driving the machine without a DEF filter, or using non-genuine SAKAI filters may lead to breakdowns due to contaminants entering the DEF pump or DEF injector. Never drive the machine without a DEF pump filter, or a non-genuine SAKAI filter.
- The DEF pump filter cannot be washed. Washing it will lower its performance, causing breakdowns in the DEF pump and DEF injector. The element must never be reused.
- If the DEF pump filter is not assembled properly, it may cause the DEF to leak. Follow the correct procedures when changing the DEF pump filter.
- The DEF freezes at -11°C . Freezing makes changing the filter difficult. Change the filter when the surrounding temperature exceeds -11°C , so that the DEF will not freeze.

To prevent freezing of the DEF and malfunctions caused by precipitation of urea after the engine is turned off, the DEF machine system automatically sucks out the DEF remaining inside the DEF injector and DEF pump, and returns it to the tank.

The machine continues running for several minutes after the engine is turned off, so clean the area around the DEF pump after the DEF system has stopped running, before changing the filter.

The DEF pump filter is located at the bottom of the DEF pump.

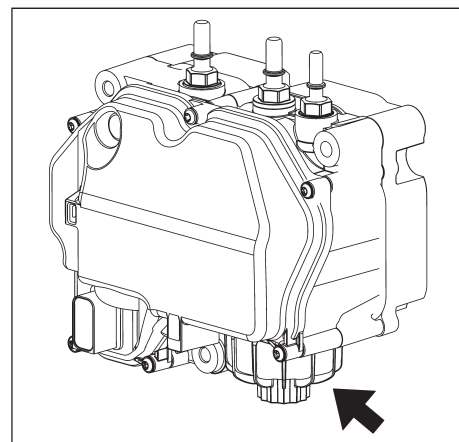

3 PERIODIC MAINTENANCE

- 1) Unscrew the DEF filter cap ①. A 27 mm wrench can be used on the cap to aid in removal.
- 2) Remove the aftertreatment DEF filter equalizing element ②.
- 3) Remove the old aftertreatment DEF dosing unit filter element ③.
A disposable service tool is included with the filter to aid in filter removal. Use the appropriate end of the tool, depending on the color of the plastic on the filter. When inserting the tool, a “click” sound can be heard which indicates proper engagement with the filter.
- 4) Slide the DEF filter equalizing element ② into the DEF filter cartridge ③.
- 5) Insert the assembly into the aftertreatment DEF dosing unit.
- 6) Install and tighten the cap ①. A 27 mm wrench can be used to install and tighten the filter cap.

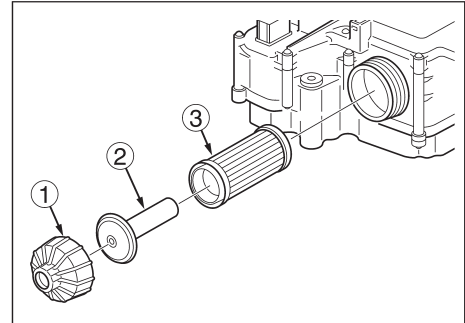
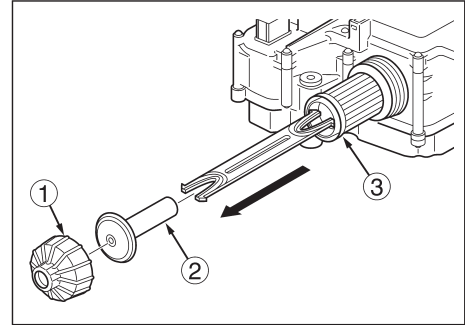

Torque Value: 20 N·m [177 in-lb]

3.6 Fluid and Lubricant Capacities

(1) General rules

- 1) Never feed water or lubricant with the strainer removed.
- 2) Use recommended lubricant and hydraulic fluid.
- 3) Do not use lubricants and hydraulic fluid of different brands.
- 4) When replacing oil, drain it completely and clean the container with flushing oil before filling new oil.
- 5) When fueling SAKAI machines, be sure to use the fuel that we specify or recommend. Nonconformance resulting from use of fuel and lube oil other than those specified or recommended by SAKAI is not covered by our warranty and repair service.

(2) Capacity

Compartment	Type of fluid	Capacity in liters (gal.)
Fuel tank	Diesel oil	215 (56.8)
Engine oil pan	Engine oil	12 (3.2)
Hydraulic oil tank	Hydraulic oil	53 (14.0)
Wheel motor	Gear oil	2.9 (0.8)
Radiator	Coolant	25 (6.6)
Vibrator	Gear oil	34 (9.0)
Transmission	Gear oil	1.2 (0.3)
Differential case	Gear oil	11 (2.9)
Final drives	Gear oil	2.0 x 2 (0.5 x 2)
DEF tank	DEF	19 (5.0)

⚠ WARNING

- **DEF on the skin may cause inflammation in some people, so contaminated clothes, shoes, etc., should be taken off and washed in cold or warm water. If there are any changes in appearance or pain, promptly seek medical help.**
- **If the DEF is accidentally swallowed, rinse out your mouth well with water, and promptly seek medical help.**
- **If the DEF gets in your eyes, rinse it out immediately in clean water for several minutes, then promptly seek medical help.**
- **Wear protective glasses when there is a danger of the DEF splattering. Wear rubber gloves if work requires you to come into contact with the DEF.**
- **Do not put anything other than DEF into the DEF tank. Diesel, gasoline, etc., in particular may cause fires. Moreover, putting additives in the tank may lead to generation of toxic gases.**
- **Opening the DEF tank cap may release toxic ammonia gas. When opening the cap or filling the tank, keep your face away from the filler port.**
- **If the DEF is spilled, promptly wipe it clean and wash with water. Neglecting to do so may lead to toxic gases or corrosive substances being given off.**

⚠ CAUTION

- Put AUS32 or ISO22241-1 certified DEF in the DEF tank.
Using anything else may cause breakdowns in the DEF SCR system.
- Keep the DEF tank topped up by refilling it at the right time.
- Keep the area around the DEF tank cap clean at all times, and take care not to allow contaminants to enter the DEF tank when opening the cap.
- When storing the machine for a month or more, fill up the DEF tank.
- On cold days, fill the tank to the designated level.

(3) Rating

Lubricant	Service classification	Ambient temp. and applicable viscosity rating			Applicable standards
		-15 – 30°C (5 – 86°F) Cold	0 – 40°C (32 – 104°F) Moderate	15 – 55°C (59 – 131°F) Tropical	
Engine oil	API grade CJ-4	SAE 5W-40	SAE 5W-40	SAE 5W-40	MIL-L-2104B
Gear oil	API grade GL5	SAE 80W-90	SAE 90	SAE 140	MIL-L-2105
Hydraulic oil	Anti wear	ISO-VG32 over VI 140	ISO-VG46 over VI 140	ISO-VG68 over VI 110	ISO-3448
Grease	Lithium type extreme pressure				NLGI-2
Fuel	Diesel oil				ASTM D975-2D
DEF	ISO 22241-1 and AUS32				

3 PERIODIC MAINTENANCE

(4) Storing the DEF

- Keep DEF containers airtight, and store them indoors in a well ventilated place avoiding direct sunlight.
- Use the container that the DEF was bought in to store it. Never store it in other containers as it will lead to loss of quality.
- Commission the disposing of the DEF to an industrial waste treatment company to make sure it is handled appropriately. Moreover, DEF containers are to be treated as industrial waste, so they too, must be disposed of in the same way.
- The temperature requirements and storage period for DEF are as shown below:

Temperature during storage	Storage period
Below 10°C	Up to 36 months
Below 25°C	Up to 18 months
Below 30°C	Up to 12 months
Below 35°C	Up to 6 months

(5) Recommended lubricants

Lubricant Oil company	Engine oil API – CJ4	Gear oil API GL 5	Hydraulic oil ISO-VG 46	Grease (NLGI – 2)
CHEVRON	DELO 400 LE Synthetic	RPM Universal Gear Lubricants	Rando HDZ 46	Multifak EP 2
BP	—	BP Energear HYPO - U	Bartran HV 46	BP Energrease LS – EP 2
CASTROL	—	EXP Gear OILS	Castrol Hyspin AWH 46	Castrol Spheerol ELP 2
EXXON MOBIL	Mobil Delvac 1 ESP	Mobilube HD	Mobil DTE 10 Excel 46	Mobilux EP 2
SHELL	—	Shell Spirax S2 A 90	Shell Tellus S2V 46	Shell Alvania Greases EP 2

⚠ CAUTION

- **Fill the fluid reservoirs with the filters installed.**
- **Use recommended fuels and lubricants only.**
- **Use the hydraulic oils which specifications are as clean as ISO4406 18/13 or above.**

3 PERIODIC MAINTENANCE

Fuse box

The fuse box houses eight 20 A-fuses, twelve 15 A-fuses, two 10 A-fuses, two 7.5 A-fuses, five 5 A-fuses, lined up with spares fitted for 20 A-fuses, 15 A-fuses, 7.5 A-fuses, 5 A-fuses and 10 A-fuse. Use fuses of correct capacity (refer to page 39).

Line fuse

The fuse box houses one 30 A, one 10 A.

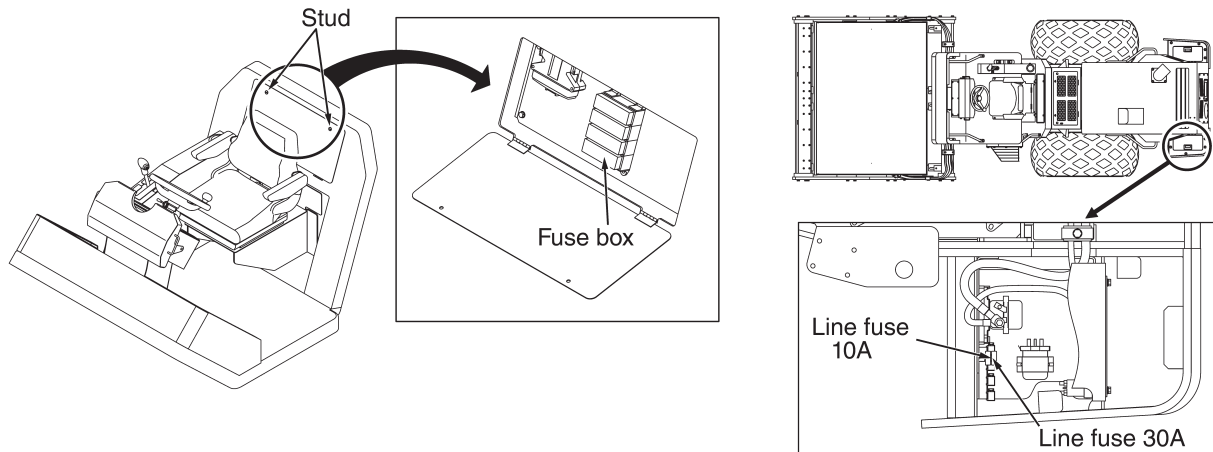

NOTE: When a fuse is burned, determine the cause before replacing.

Battery

IMPORTANT

When this machine is shipped, maintenance free battery is installed.

- ★ Leaving the battery unused for long without attention or using its power excessively at a time can cause damage to the plates, leading to a shortened life.
- ★ For long-term storage, charge it fully, tighten the caps securely, store in a cool and dry place, and check the level of charge at least once a month.
- ★ Maintain the level of charge above 75%.
- ★ In cold weather, it is desirable to start the engine with the battery charged 100%. Do not try to start the engine with less than 75%.

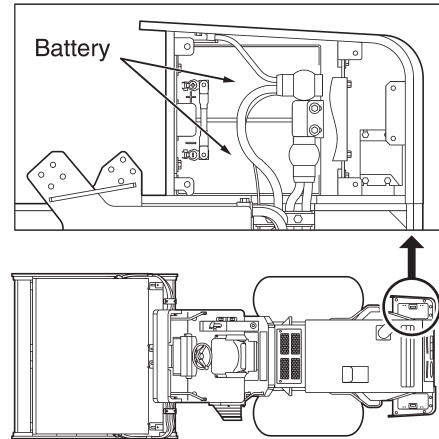

WARNING

- The battery contains diluted sulfuric acid, which will dissolve clothes and skin. Should you get battery fluid on your clothes or skin, wash it off immediately with copious quantities of clean water.
- If you get it in your eyes, rinse them straight away with clean water and immediately seek the help of a doctor.
- If you accidentally ingest it, drink copious quantities of water and immediately seek the help of a doctor.
- Always wear safety glasses when handling the battery.
- The battery generates hydrogen gas, so there is a danger of explosions. Avoid recharging the battery, keep cigarettes and flames away, etc., in poorly ventilated places when there is a danger of generating sparks.
- The inspection and handling of batteries should be carried out with the engine turned off and the starter switch in the ○ position.
- Turn the starter switch to the ○ position, then wait at least 30 seconds before removing the battery. An abnormality may arise in the ECM (engine control module).
- Be careful not to accidentally connect the two battery terminals with tools or other metallic objects.
- Tangled terminals may generate sparks due to improper connections, resulting in the danger of explosions. Make sure terminals are connected firmly.
- The battery is for starting the engine and operating electrical equipment on the machine. Do not use it for any other purpose.

CAUTION

The power-supply voltage of this machine is 24 V.

4 SPECIFICATIONS

4 SPECIFICATIONS

(1) SV544D

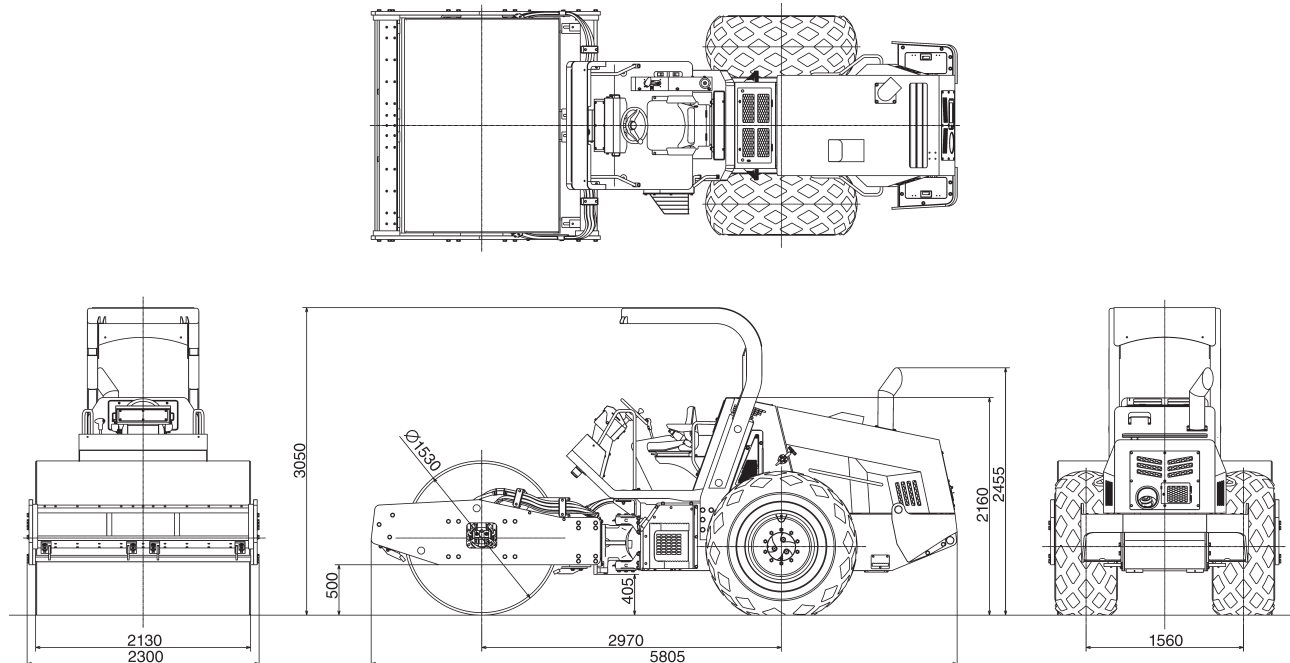

Model	SV544D	Vibrating power	Low	High
Weight		Frequency	33.3 Hz {2,000 vpm}	28.8 Hz {1,730 vpm}
Operating weight	11,000 kg (24,250 lbs)	Centrifugal force	150 kN (33,720 lbs)	255 kN (57,325 lbs)
On front axle	5,790 kg (12,765 lbs)	Gradeability	63% (32°)	
On rear axle	5,210 kg (11,485 lbs)	Rolling width	2,130 mm (84")	
Dimension		Minimum turning radius	5.6 m (221")	
Overall length	5,805 mm (229")	Engine		
Overall width	2,300 mm (91")	Model	CUMMINS "QSF3.8" Diesel Engine with turbo charger	
Overall height	3,050 mm (120")	Total displacement	3.758 litres (299 cu.in)	
Wheelbase	2,970 mm (117")	Rated output	97kW {130HP} / 2,200min ⁻¹	
Wheel		Max. torque	488 N·m / 1,600 min ⁻¹	
Front	Roll (dia. x width)	Tank capacity		
Smooth	1,530 x 2,130 mm (60" x 84")	Fuel tank	215 litres (56.8 gal)	
Rear	Tire	Hydraulic oil tank	53 litres (14 gal)	
	23.1-26-8 PR (OR)			
Performance				
Travel speed	1st 0-4 km/h (0-2.5 mile/h)			
	2nd 0-6 km/h (0-3.7 mile/h)			
	3rd 0-10 km/h (0-6.2 mile/h)			

NOTE: 1) Gradeability is the calculated value. It may vary with ground surface conditions.

2) According to European Standards (EN500-1, ISO 6165, etc.), the weight are defined as follows.
Operating weight: Fuel=50%, Water=50%, Operator=75kg.

(2) SV544DF

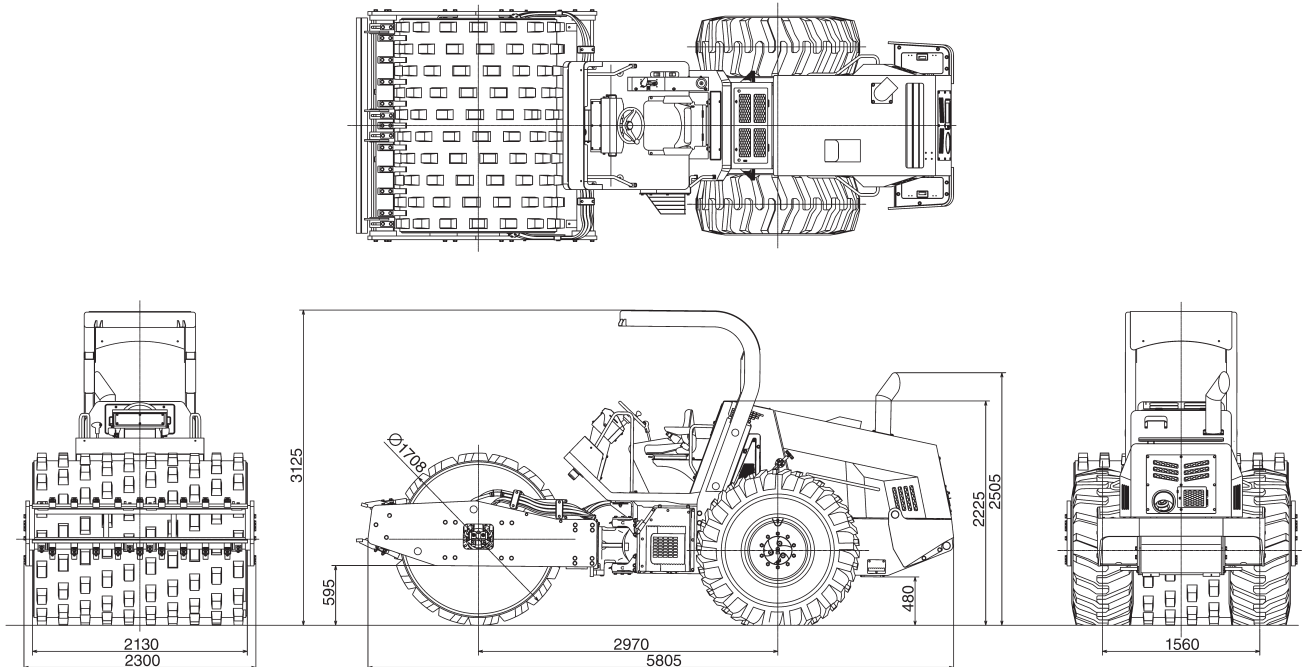

Model	SV544DF		Vibrating power	Low	High
Weight			Frequency	33.3 Hz {2,000 vpm}	28.8 Hz {1,730 vpm}
Operating weight	12,680 kg (27,955 lbs)		Centrifugal force	150 kN (33,720 lbs)	255 kN (57,325 lbs)
On front axle	7,545 kg (16,635 lbs)		Gradeability	63% (32°)	
On rear axle	5,135 kg (11,320 lbs)		Rolling width	2,130 mm (84")	
Dimension			Minimum turning radius	5.6 m (221")	
Overall length	5,805 mm (229")		Engine		
Overall width	2,300 mm (91")		Model	CUMMINS "QSF3.8" Diesel Engine with turbo charger	
Overall height	3,125 mm (123")		Total displacement	3.758 litres (229 cu.in)	
Wheelbase	2,970 mm (117")		Rated output	97kW {130HP} / 2,200min ⁻¹	
Wheel			Max. torque	488 N·m / 1,600 min ⁻¹	
Front	Roll (dia. x width)		Tank capacity		
Smooth	1,530 x 2,130 mm (60" x 84")		Fuel tank	215 litres (56.8 gal)	
Pad	1,708 x 2,130 mm (67" x 84")		Hydraulic oil tank	53 litres (14 gal)	
Rear	Tire				
	23.1-26-12 PR (OR)				
Performance					
Travel speed	1st 0-4 km/h (0-2.5 mile/h)				
	2nd 0-6 km/h (0-3.7 mile/h)				
	3rd 0-10 km/h (0-6.2 mile/h)				

NOTE: 1) Gradeability is the calculated value. It may vary with ground surface conditions.
 2) According to European Standards (EN500-1, ISO 6165, etc.), the weight are defined as follows.
 Operating weight: Fuel=50%, Water=50%, Operator=75kg.

4 SPECIFICATIONS

(3) SV544T

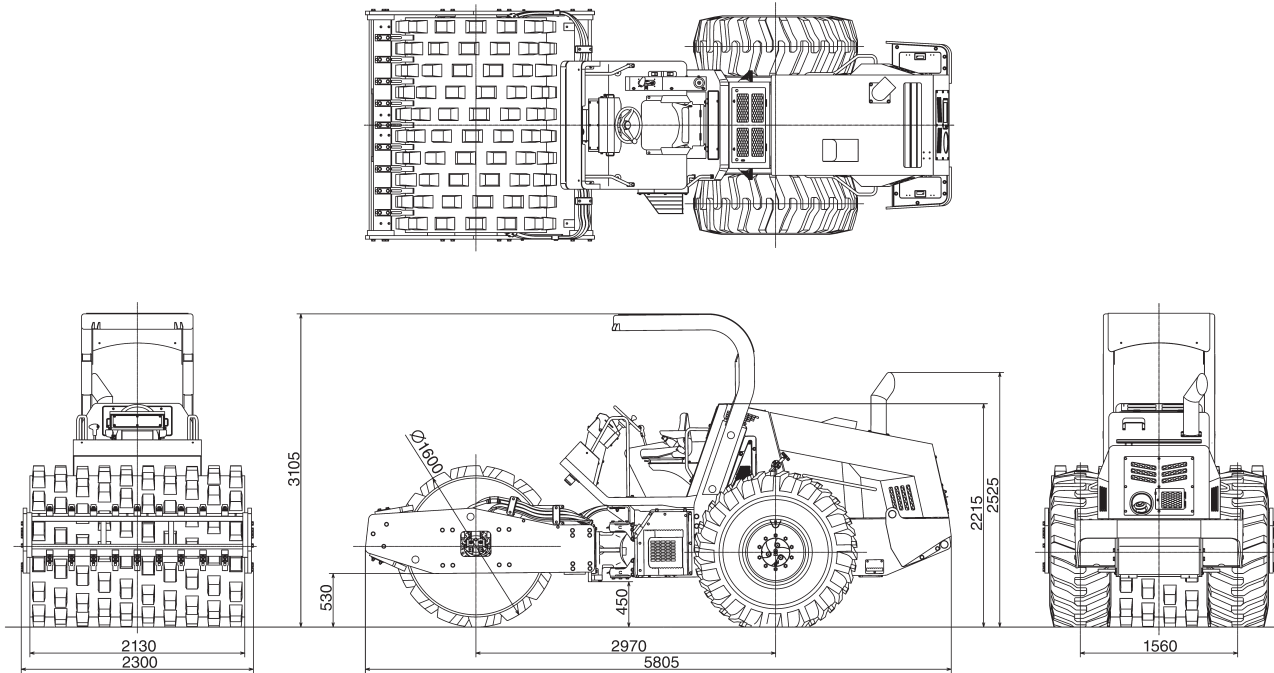

Model	SV544T	Vibrating power	Low	High
Weight		Frequency	33.3 Hz {2,000 vpm}	28.8 Hz {1,730 vpm}
Operating weight	11,380 kg (25,090 lbs)	Centrifugal force	150 kN (33,720 lbs)	255 kN (57,325 lbs)
On front axle	6,175 kg (13,615 lbs)	Gradeability	63% (32°)	
On rear axle	5,205 kg (11,475 lbs)	Rolling width	2,130 mm (84")	
Dimension		Minimum turning radius	5.6 m (221")	
Overall length	5,805 mm (229")	Engine		
Overall width	2,300 mm (91")	Model	CUMMINS "QSF3.8" Diesel Engine with turbo charger	
Overall height	3,105 mm (122")	Total displacement	3.758 litres (229 cu.in)	
Wheelbase	2,970 mm (117")	Rated output	97kW {130HP} / 2,200min ⁻¹	
Wheel		Max. torque	488 N·m / 1,600 min ⁻¹	
Front	Roll (dia. x width)	Tank capacity		
Pad	1,600 x 2,130 mm (63" x 84")	Fuel tank	215 litres (56.8 gal)	
Rear	Tire	Hydraulic oil tank	53 litres (14 gal)	
	23.1-26-12 PR (OR)			
Performance				
Travel speed	1st 0-4 km/h (0-2.5 mile/h)			
	2nd 0-6 km/h (0-3.7 mile/h)			
	3rd 0-10 km/h (0-6.2 mile/h)			

NOTE: 1) Gradeability is the calculated value. It may vary with ground surface conditions.

2) According to European Standards (EN500-1, ISO 6165, etc.), the weight are defined as follows.
Operating weight: Fuel=50%, Water=50%, Operator=75kg.

(4) SV544TF

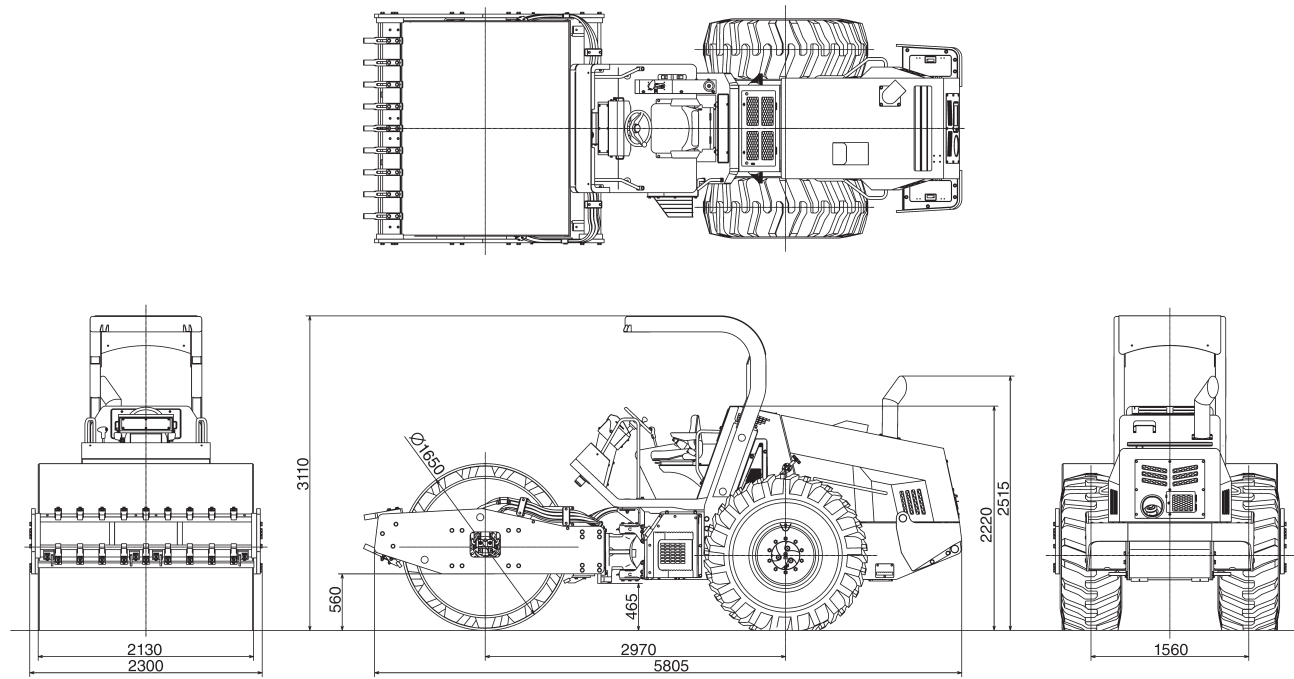

Model	SV544TF		Vibrating power	Low	High
Weight			Frequency	33.3 Hz {2,000 vpm}	28.8 Hz {1,730 vpm}
Operating weight	13,650 kg (30,095 lbs)		Centrifugal force	150 kN (33,720 lbs)	255 kN (57,325 lbs)
On front axle	8,460 kg (18,650 lbs)		Gradeability	63% (32°)	
On rear axle	5,190 kg (11,440 lbs)		Rolling width	2,130 mm (84")	
Dimension			Minimum turning radius	5.6 m (221")	
Overall length	5,805 mm (229")		Engine		
Overall width	2,300 mm (91")		Model	CUMMINS "QSF3.8" Diesel Engine with turbo charger	
Overall height	3,110 mm (122")		Total displacement	3.758 litres (229 cu.in)	
Wheelbase	2,970 mm (117")		Rated output	97kW {130HP} / 2,200min ⁻¹	
Wheel			Max. torque	488 N·m / 1,600 min ⁻¹	
Front	Roll (dia. x width)		Tank capacity		
Smooth	1,650 x 2,130 mm (65" x 84")		Fuel tank	215 litres (56.8 gal)	
Pad	1,600 x 2,130 mm (63" x 84")		Hydraulic oil tank	53 litres (14 gal)	
Rear	Tire				
	23.1-26-12 PR (OR)				
Performance					
Travel speed	1st 0 - 4 km/h (0 - 2.5 mile/h)				
	2nd 0 - 6 km/h (0 - 3.7 mile/h)				
	3rd 0 - 10 km/h (0 - 6.2 mile/h)				

NOTE: 1) Gradeability is the calculated value. It may vary with ground surface conditions.
 2) According to European Standards (EN500-1, ISO 6165, etc.), the weight are defined as follows.
 Operating weight: Fuel=50%, Water=50%, Operator=75kg.

4 SPECIFICATIONS

(5) SV544TB

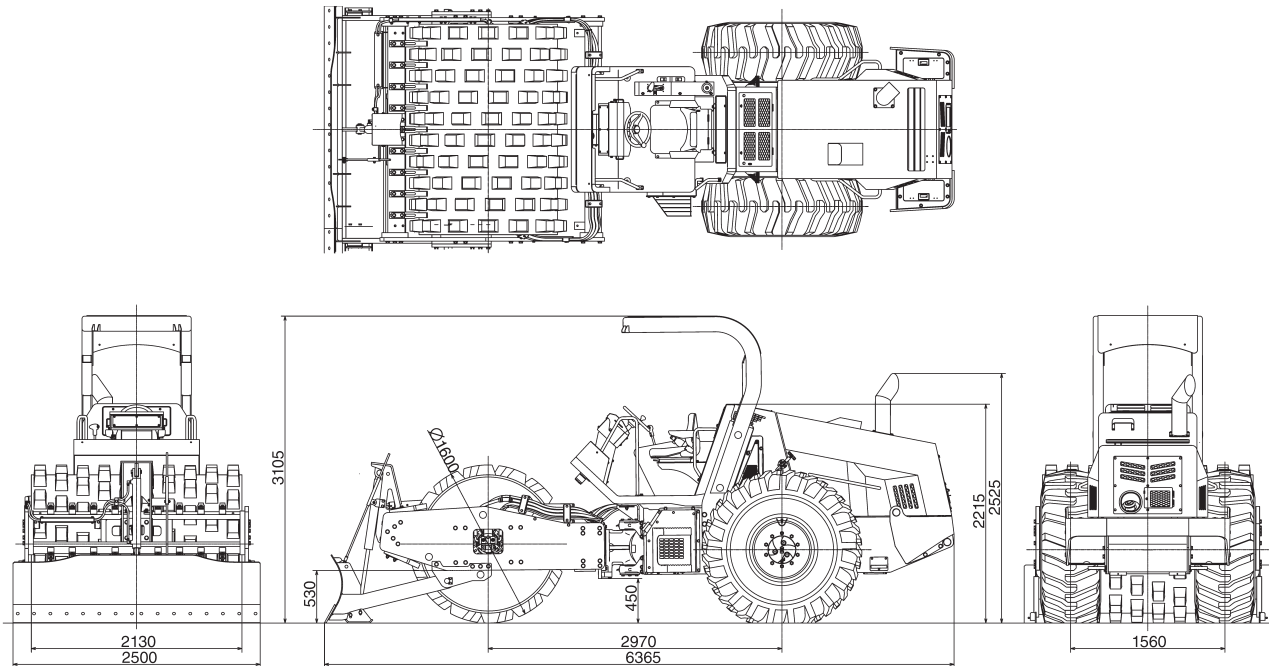

Model	SV544TB	Vibrating power	Low	High
Weight		Frequency	33.3 Hz {2,000 vpm}	28.8 Hz {1,730 vpm}
Operating weight	12,140 kg (26,765 lbs)	Centrifugal force	150 kN (33,720 lbs)	255 kN (57,325 lbs)
On front axle	7,270 kg (16,025 lbs)	Gradeability	63% (32°)	
On rear axle	4,870 kg (10,735 lbs)	Rolling width	2,130 mm (84")	
Dimension		Minimum turning radius	5.6 m (221")	
Overall length	6,365 mm (251")	Engine		
Overall width	2,500 mm (98")	Model	CUMMINS "QSF3.8" Diesel Engine with turbo charger	
Overall height	3,105 mm (122")	Total displacement	3.758 litres (229 cu.in)	
Wheelbase	2,970 mm (117")	Rated output	97kW {130HP} / 2,200min ⁻¹	
Wheel		Max. torque	488 N·m / 1,600 min ⁻¹	
Front	Roll (dia. x width)	Tank capacity		
Pad	1,600 x 2,130 mm (63" x 84")	Fuel tank	215 litres (56.8 gal)	
Rear	Tire	Hydraulic oil tank	53 litres (14 gal)	
	23.1-26-12 PR (OR)			
Performance				
Travel speed	1st 0-4 km/h (0-2.5 mile/h)			
	2nd 0-6 km/h (0-3.7 mile/h)			
	3rd 0-10 km/h (0-6.2 mile/h)			

NOTE: 1) Gradeability is the calculated value. It may vary with ground surface conditions.
 2) According to European Standards (EN500-1, ISO 6165, etc.), the weight are defined as follows.
 Operating weight: Fuel=50%, Water=50%, Operator=75kg.

(6) SV544FB

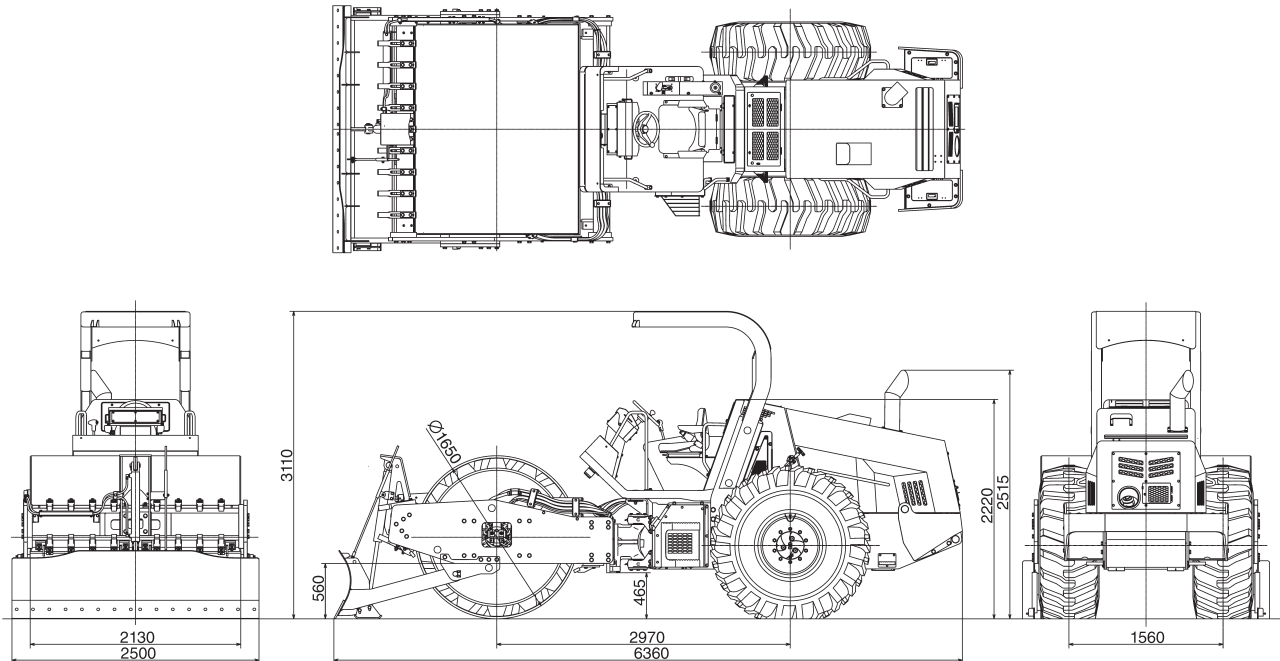

Model	SV544FB	Vibrating power	Low	High
Weight		Frequency	33.3 Hz {2,000 vpm}	28.8 Hz {1,730 vpm}
Operating weight	14,410 kg (31,770 lbs)	Centrifugal force	150 kN (33,720 lbs)	255 kN (57,325 lbs)
On front axle	9,555 kg (21,065 lbs)	Gradeability	63% (32°)	
On rear axle	4,855 kg (10,705 lbs)	Rolling width	2,130 mm (84")	
Dimension		Minimum turning radius	5.7 m (225")	
Overall length	6,360 mm (250")	Engine		
Overall width	2,500 mm (98")	Model	CUMMINS "QSF3.8" Diesel Engine with turbo charger	
Overall height	3,110 mm (122")	Total displacement	3.758 litres (229 cu.in)	
Wheelbase	2,970 mm (117")	Rated output	97kW {130HP} / 2,200min ⁻¹	
Wheel		Max. torque	488 N·m / 1,600 min ⁻¹	
Front	Roll (dia. x width)	Tank capacity		
Smooth	1,650 x 2,130 mm (65" x 84")	Fuel tank	215 litres (56.8 gal)	
Pad	1,600 x 2,130 mm (63" x 84")	Hydraulic oil tank	53 litres (14 gal)	
Rear	Tire			
	23.1-26-12 PR (OR)			
Performance				
Travel speed	1st 0 - 4 km/h (0 - 2.5 mile/h)			
	2nd 0 - 6 km/h (0 - 3.7 mile/h)			
	3rd 0 - 10 km/h (0 - 6.2 mile/h)			

NOTE: 1) Gradeability is the calculated value. It may vary with ground surface conditions.
 2) According to European Standards (EN500-1, ISO 6165, etc.), the weight are defined as follows.
 Operating weight: Fuel=50%, Water=50%, Operator=75kg.



SAKAI AMERICA, INC.

90 INTERNATIONAL PKWY ADAIRSVILLE,
GA 30103

Phone : 770-877-9433

Fax : 770-877-9886